

Installation Instructions / Warranty

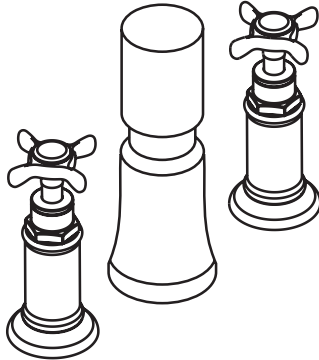

Vertical Spray Bidet Fitting

Rough 1322X181

Axor Trim Kits

Citterio cross handle 39224XX0

Citterio lever handle 39225XX0

Starck 10220XX0

Steel 35220800

Uno 38220XX0

Terrano cross handle 37224XX0

Terrano lever handle 37225XX0

Carlton cross handle 17224XX0

Carlton lever handle 17225XX0

Phoenix cross handle 17226XX0

Phoenix lever handle 17227XX0

Montreux 16521XX0

AXOR[®]

hansgrohe

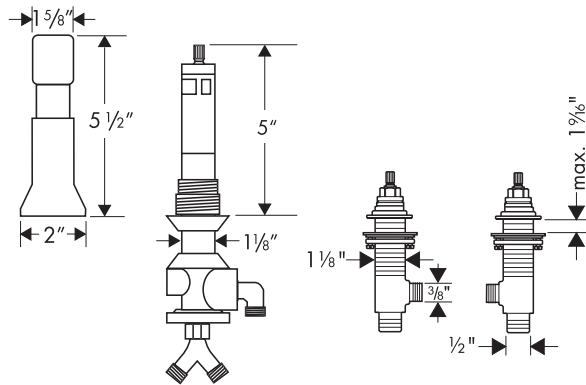

Technical Specification

Recommended operating pressure 45 - 80 psi
 Recommended hot water temp. 120°F - 140°F*
 Flow rate 2.2 gpm

Hole sizes

valves	1 1/4"
transfer valve	1 1/4"
pull rod	3/8" min.

*Know and follow all applicable local plumbing codes when setting the temperature on the water heater. In Massachusetts, the water heater may be set no higher than 112°F.

Important: This valve is for use on vertical spray bidets only. It is not suitable for use on other fixtures.

The transfer valve has an integral vacuum breaker.

Installation Considerations

For best results, Hansgrohe recommends installation by a licensed professional plumber.

The hot and cold valves require 1/2" supply lines, which are not provided by Hansgrohe.

Large differences in pressure between the hot and cold supplies should be balanced.

The hot and cold supplies must be thoroughly flushed before installation to prevent damage to the valve cartridges.

Rough-in Installation Instructions

Install the transfer valve

Install the y-connector and seal on the bottom of the transfer valve. Screw the connecting hoses to the y-connector.

Screw the elbow connector to the outlet port on the side of the transfer valve. The arrow on the elbow connector indicates the direction of the water flow. It should point downward. Screw the spray hose to the elbow connector.

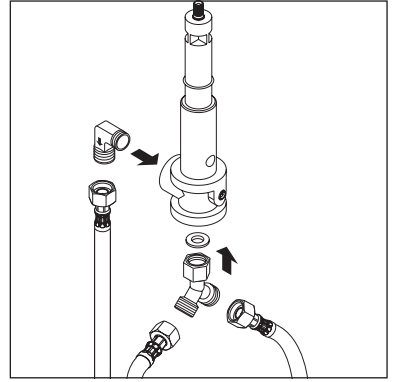

Push the transfer valve, nylon washer, and one of the china seals (tapered side up) through the transfer valve hole in the bidet.

Install the second china seal, tapered side down.

Thread the valve mounting nut to the top of the transfer valve as far as it will go. The valve mounting nut should rest on the mounting surface.

Make sure that the transfer valve stands straight.

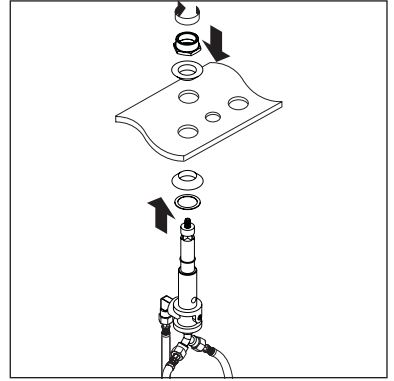

Install the spray assembly

Position the spray and sealing washer in the hole in the bidet.

Install the washer and mounting nut.

Connect the spray hose to the spray, being careful not to twist or kink the hose.

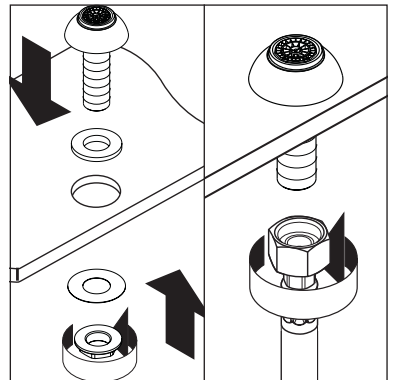

Install the pop-up guide assembly

Remove the nut, metal washer, and sealing washer from the pop-up guide assembly.

Position the pop-up guide and sealing washer on the proper hole on the bidet.

Install the metal washer and nut.

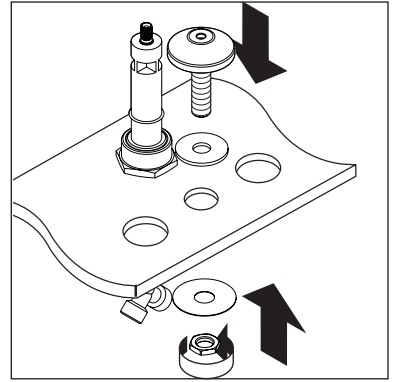

Install the pop-up drain

Remove the plunger assembly.

Unscrew the drain outlet flange from the tee.

Unscrew the tailpiece from the tee. Wrap the threads with Teflon tape and replace.

Install the white, flexible sealing gasket on the flange. Sit it in the sink outlet.

From below, install the black mack gasket, friction ring, and retainer nut to the flange. Do not fully tighten the nut at this time.

Thread the tee and tailpiece on the flange. The pivot must face the faucet. Turn the drain assembly if necessary.

Tighten the retainer nut.

Place the plunger assembly in the drain.

Install the horizontal rod so that the end goes through the loop in the bottom of the height adjuster.

Install and tighten the pivot ball nut.

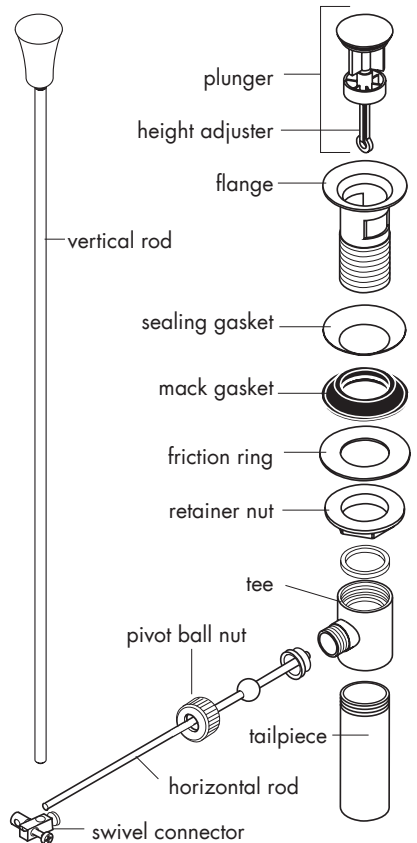

Attach the swivel connector to the end of the horizontal rod.

Attach the swivel connector to the end of the vertical rod. Position as desired, and tighten with a small, flathead screwdriver.

Trim Kit Installation

Install the valves: Starck and Citterio only

Remove the valve mounting nuts from the valves.

Push the valves up into the holes. Install the mounting plates on the holes.

Tighten the tensioning screws.

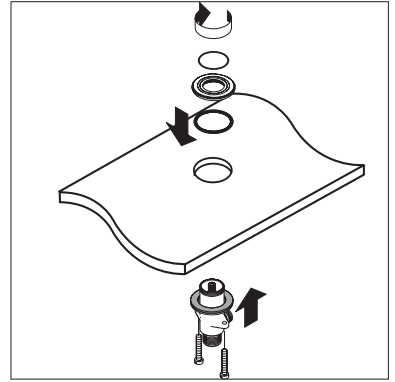

Install the valves: all other styles

Remove the plaster shields, mounting plates, and stop rings from the valves.

Push the valve up through the hole. Slide the stop ring onto the valve. Install the mounting plate. The stop ring will stop it at the proper height.

Rest the mounting plate on the mounting surface. Tighten the mounting nut firmly against the underside of the mounting surface. Tighten the tensioning screws.

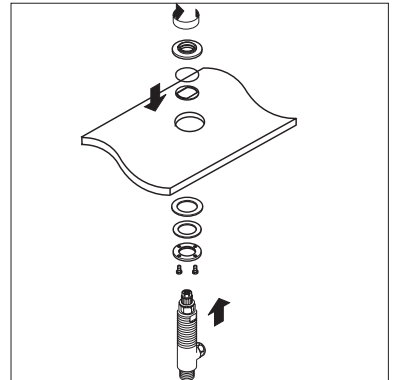

All models:

Connect the connecting hoses to the valve outlets. Hold the hose steady with one wrench while tightening the hose nut with a second wrench.

Install the hot and cold supply lines (not included) on the valve inlets.

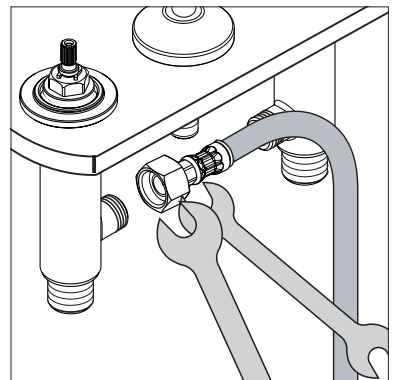

Install the transfer valve trim

Screw the sleeve down onto the transfer valve.

Push the handle over the stem and secure it with the screw.

Line up the locator tab on the screw cover with the notch in the handle. Press down firmly.

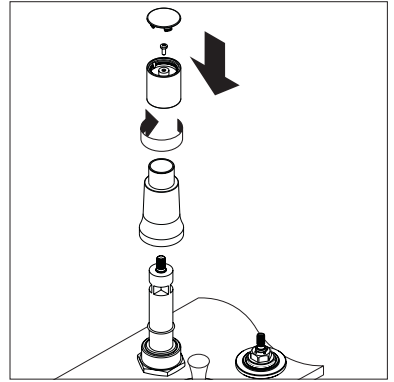

Install the handles

Carlton/Phoenix/Terrano

Screw the escutcheons down over the mounting plates.

Position the handle over the valve with the lever or cross in the desired off position. Hold the lever or cross steady with one hand. With the other hand, rotate the "bell" clockwise, so that it threads down over the valve.

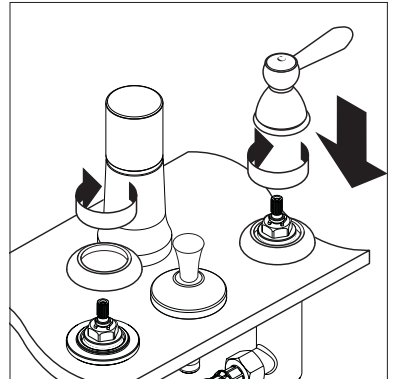

Uno / Steel

Install the white plastic snap connectors and screws on the valves.

Screw the escutcheons into place over the mounting plates.

Position the handle over the valve. Press downward firmly, so that the handle snaps into place over the snap connector.

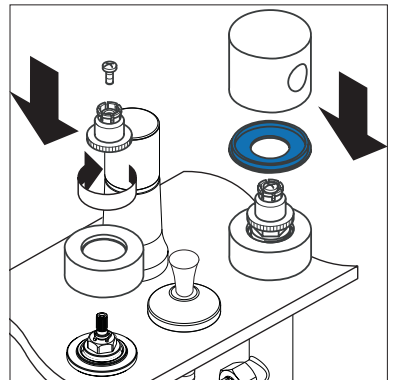

Citterio / Starck

Position the handle over the valve. While holding the cross or lever steady with one hand, use the other hand to thread the escutcheon down over the mounting plate.

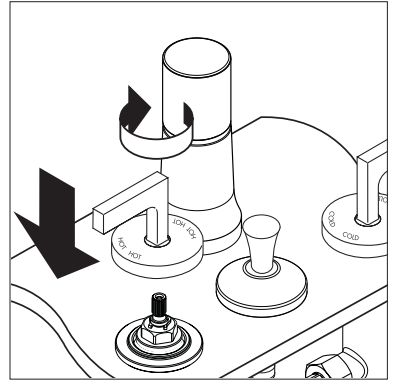

Montreux

Position the handle over the valve. While holding the cross steady with one hand, use the other hand to turn the escutcheon clockwise to thread it onto the valve.

Lightly grease the o-rings. Press the hot and cold caps into place on the handles.

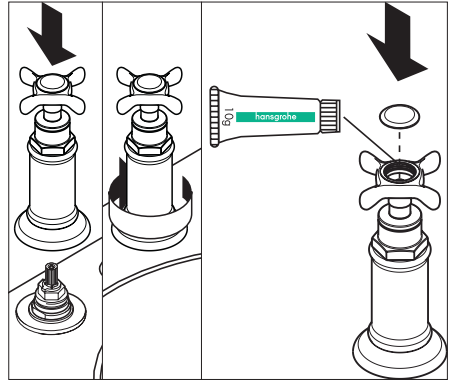

User Instructions

Turn the left handle to obtain hot water, the right handle for cold water.

Turn the transfer valve handle to select between the vertical spray and the rim wash. While the vertical spray is functioning, water will also come from the rim wash.

Replacement Parts - Rough

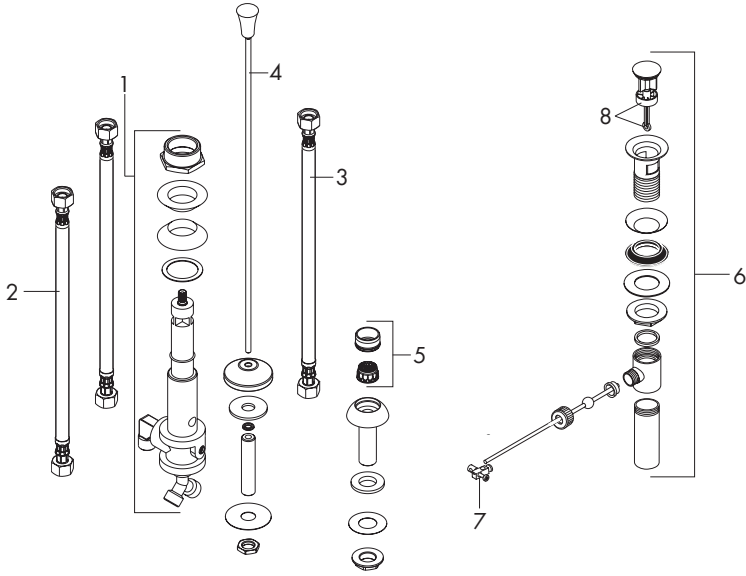

Replacement Parts - Trim

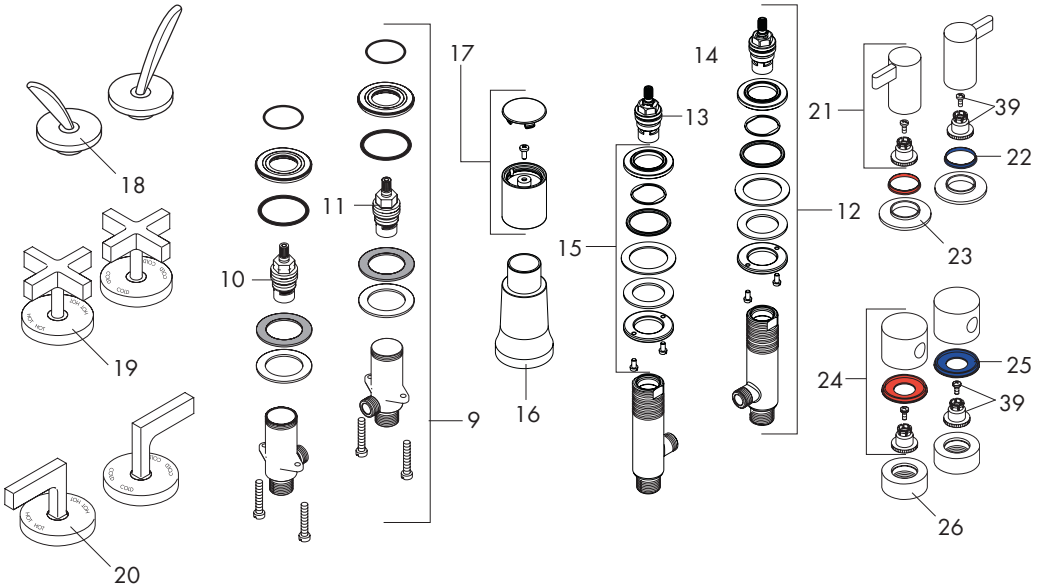

Cleaning Recommendation for Hansgrohe Products

Modern lavatory faucets, kitchen faucets, and showers consist of very different materials to comply with the needs of the market with regard to design and functionality. To avoid damage and returns, it is necessary to consider certain criteria when cleaning.

Cleaning Materials for Faucets and Showers

Acids are a necessary ingredient of cleaning materials for removing lime, however please pay attention to the following points when cleaning faucets and showers:

- Only use cleaning materials which are explicitly intended for this type of application.
- Never use cleaning materials which contain hydrochloric, formic, phosphoric, or acetic acid, as they cause considerable damage.
- Never mix one cleaning material with another.
- Never use cleaning materials or appliances with an abrasive effect, such as unsuitable cleaning powders, sponge pads, or micro fiber cloths.

Cleaning Instructions for Faucets and Showers

Please follow the cleaning material manufacturer's instructions. In addition, pay attention to the following points:

- Clean the faucets and showers as and when required
- Use the amount of cleaning product and the amount of time recommended by the manufacturer. Do not leave the cleaner on the fixture longer than necessary.
- Regular cleaning can prevent calcification.
- When using spray cleaners, spray first onto a soft cloth or sponge. Never spray directly onto the faucet as droplets can enter openings and gaps and cause damage.
- After cleaning, rinse thoroughly with clean water to remove any cleaner residue.

Important

Residues of liquid soaps, shampoos, and shower foams can also cause damage, so rinse with clean water after using.

Please note: if the surface is already damaged, the effect of cleaning materials will cause further damage.

**Components with damaged surfaces must be replaced or injury could result.
Damage caused by improper treatment is not covered under the warranty.**

Limited Lifetime Consumer Warranty

This product has been manufactured and tested to the highest quality standards by Hansgrohe, Inc. ("Hansgrohe"). This warranty is limited to Hansgrohe products which are purchased by a consumer in the United States after March 1, 1996, and installed in either the United States or Canada.

WHO IS COVERED BY THE WARRANTY

This warranty extends to the original consumer purchaser only. This warranty is non-transferable.

WHAT IS COVERED BY THE WARRANTY

This warranty covers only your Hansgrohe manufactured product. Hansgrohe warrants this product against defects in material or workmanship as follows: Hansgrohe will repair at no charge for parts only or, at its option, replace any product or part of the product that proves defective because of improper workmanship and/or material, under normal installation, use, service and maintenance. If Hansgrohe is unable to provide a replacement and repair is not practical or cannot be timely made, Hansgrohe may elect to refund the purchase price in exchange for the return of the product.

LENGTH OF WARRANTY

Replacement or repaired parts of products will be covered for the term of this warranty as stated in the following two sentences. If you are a consumer who purchased the product for use primarily for personal, family, or household purposes, this warranty extends for as long as you own the product and the home in which the product is originally installed. If you purchased the product for use primarily for any other purpose,

including, without limitation, a commercial purpose, this warranty extends only (i) for 1 year, with respect to Hansgrohe and Commercial products, and (ii) for 5 years, with respect to AXOR products.

THIS WARRANTY DOES NOT COVER, AND HANSGROHE WILL NOT PAY FOR:

- A. Conditions, malfunctions or damage not resulting from defects in material or workmanship.
- B. Conditions, malfunctions or damage resulting from (1) normal wear and tear, improper installation, improper maintenance, misuse, abuse, negligence, accident or alteration, or (2) the use of abrasive or caustic cleaning agents or "no-rinse" cleaning products, or the use of the product in any manner contrary to the product instructions. (3) Conditions in the home such as excessive water pressure or corrosion.
- C. Labor or other expenses for the disconnection, deinstallation, or return of the product for warranty service, or for installation or reinstallation of the product (including but not limited to proper packaging and shipping costs), or for installation or reinstallation of the product.
- D. Accessories, connected materials and products, or related products not manufactured by Hansgrohe.

TO OBTAIN WARRANTY PARTS OR INFORMATION

Contact your Hansgrohe retailer, or contact Technical Service at:

Hansgrohe Inc.
1492 Bluegrass Lakes Parkway
Alpharetta GA 30004
Toll-free (800) 334-0455.

In requesting warranty service, you will need to provide

- 1. The sales receipt or other evidence of the date and place of purchase.
- 2. A description of the problem.
- 3. Delivery of the product or the defective part, postage prepaid and carefully packed and insured, to Hansgrohe Inc. 1492 Bluegrass Lakes Parkway, Alpharetta, Georgia 30004, Attention: Technical Service, if required by Hansgrohe.

When warranty service is completed, any repaired or replacement product or part will be returned to you postage prepaid.

EXCLUSIONS AND LIMITATIONS

REPAIR OR REPLACEMENT (OR, IN LIMITED CIRCUMSTANCES, REFUND OF THE PURCHASE PRICE) AS PROVIDED UNDER THIS WARRANTY IS THE EXCLUSIVE REMEDY OF THE PURCHASER. HANSGROHE NEITHER ASSUMES NOR AUTHORIZES ANY PERSON TO CREATE FOR IT ANY OBLIGATION OR LIABILITY IN CONNECTION WITH THIS PRODUCT.

HANSGROHE SHALL NOT BE LIABLE TO PURCHASER OR ANY PERSON FOR ANY INCIDENTAL, SPECIAL, OR CONSEQUENTIAL DAMAGES, ARISING OUT OF BREACH OF THIS WARRANTY OR ANY IMPLIED WARRANTY (INCLUDING MERCHANTABILITY).

Some States do not allow the exclusion or limitation of incidental or consequential damages, so the above limitation or exclusion may not apply to you. This warranty gives you specific legal rights, and you may have other rights which vary from State to State. You may be required by law to give us a reasonable opportunity to correct or cure any failure to comply before you can bring any action in court against us under the Magnuson-Moss Warranty Act.

PRODUCT INSTRUCTIONS AND QUESTIONS

Upon purchase or prior to installation, please carefully inspect your Hansgrohe product for any damage or visible defect. Prior to installing, always carefully study the enclosed instructions on the proper installation and the care and maintenance of the product. If you have questions at any time about the use, installation, or performance of your Hansgrohe product, or this warranty, please call or write to us or call us toll-free at 800 334 0455.

hansgrohe

Hansgrohe, Inc. • 1490 Bluegrass Lakes Parkway • Alpharetta, GA 30004
Tel. 770 360-9880 • Fax 770 360 9887

www.hansgrohe-USA.com