

Product Features

- Four ports – one inlet, three outlets
- Controls three functions
- Functions may be used individually or any two simultaneously
- Ceramic cartridge
- Max. flow rate 17 gpm @ 44 psi
- 3/4" NPT female inlet and outlets

Code Compliance

This unit meets or exceeds the following:

- ASME A112.18.1
- CSA B125.1
- Listed by IAPMO
- Approved for use in Massachusetts

Required Accessories

Quattro trim kit – many styles available

Optional Accessories

1/2" Extension (deep rough-in) kit

92630000

Installation Notes

- No "off" position
- When used with thermostatic mixer 15373181 or 15374181, volume control valve must also be used
- Can be used with Equilibrium pressure balance valve 13408181

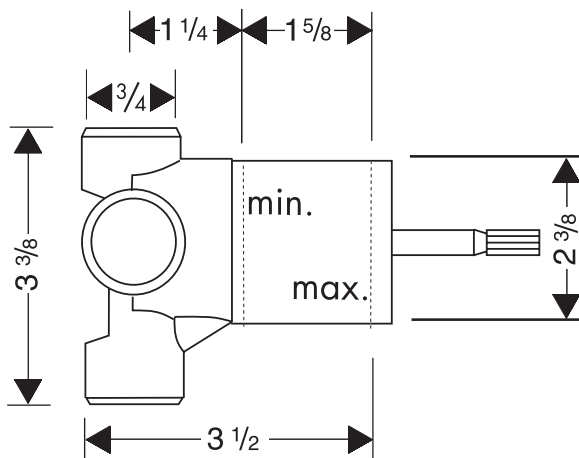

The measurements shown are for reference only.

Products and specifications shown are subject to change without notice.

Specification sheet revised 11/2007