

Installation Instructions / Warranty

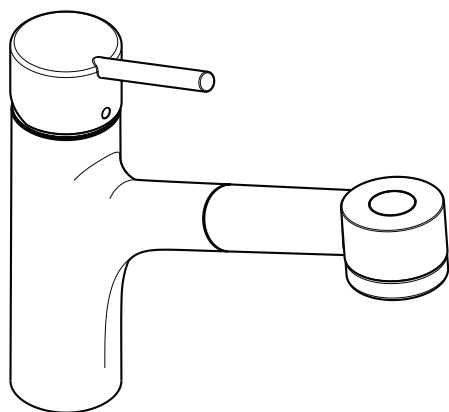

Interaktiv S
06462XXX

hansgrohe

Interaktiv S

Single Control Kitchen Faucet
06462XXX

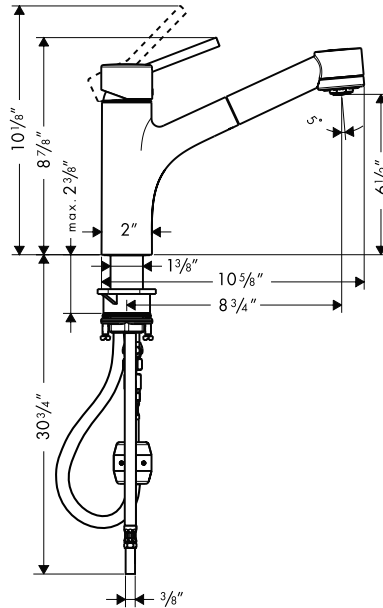

Product Specifications:

Hole size in mounting surface	Minimum 1-1/2"
Maximum mounting surface depth	2-3/8"
Flow rate	2.2 GPM
Maximum incoming water pressure	145 PSI
Recommended incoming water pressure	22 - 72.5 PSI
Recommended incoming hot water temp	120° - 140° F*
M3 cartridge with high temperature limit stop	

*Some governing bodies require that the water heater be set to 120° F or less. Please know and follow all applicable local codes when setting the temperature on the water heater.

Installation Considerations

This faucet requires supply stops with 3/8" compression fittings (not included)

Make sure that the faucet is complete and in good condition and that you have all necessary tools and supplies before beginning installation.

Protection against back siphonage is provided by a check valve in the sprayhead.

Installer: Please leave this manual with the customer as it contains valuable information on the faucet.

Install baseplate 06329XXX, (optional - not included)

Position the baseplate and gasket on the faucet deck. From under the sink, install the mounting flanges and tighten the mounting collars by hand.

The baseplate can be used on a kitchen sink with fewer than three holes. Remove and discard the threaded studs on the bottom of the baseplate. Align the baseplate and the gasket visually.

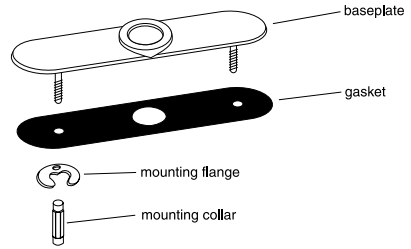

Install the faucet:

Remove the mounting nut, metal washer, fiber washer and spacer from the faucet.

Sit the faucet on the mounting surface.

If the mounting surface is thin (less than 1 3/8") and there is sufficient space, install the gray plastic spacer. If the mounting surface is greater than 1 3/8", or if there is insufficient space, omit the spacer.

Loosely install the fiber washer, metal washer and mounting nut.

Check the orientation of the faucet. The spout swivels 150° and should swivel evenly to the right and to the left. If it is satisfactory, finish tightening the mounting nut and the tensioning screws.

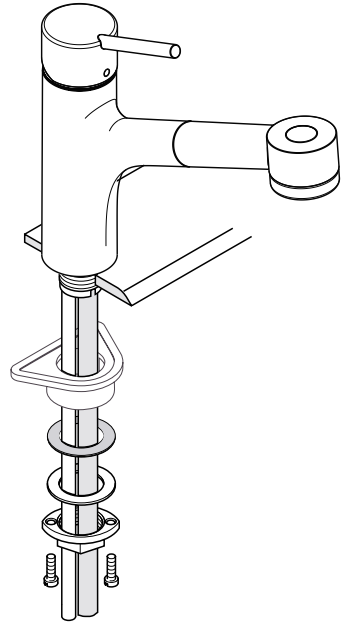

Install the handspray hose:

slide the nut, cone washer, brass washer and black rubber washer over the end of the connecting hose. Hold the handspray hose steady while tightening the nut. **Do not allow the handspray hose to twist.** Finish tightening the nut with a wrench.

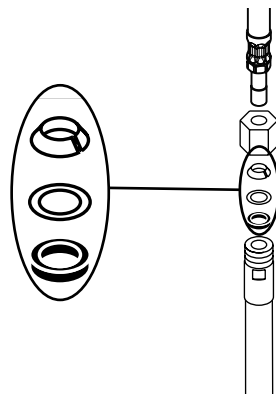

Connect the supply hoses:

use 3/8" compression fittings (not included) to connect the hot and cold supply hoses to the stops. Use two wrenches, as shown in the diagram, to prevent the hoses from twisting.

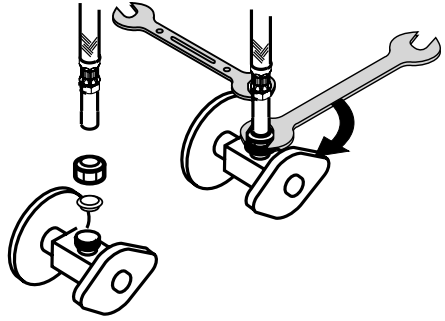

Install the hose weight: proper positioning of the hose weight insures that the hose will retract smoothly.

Install the hose weight to the handspray hose. Pull the hose out and guide it back into position. If it does not retract smoothly, or the sprayhead does not stay in place when resting in the spout, reposition the weight.

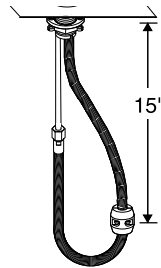

Turn on the water and check all connections for leaks.

User instructions

Pivot the handle up to turn the water on, down to turn the water off. Pivot the handle to the right for cooler water, to the left for hot water.

If the flow of water diminishes, remove and clean the hose filter screen.

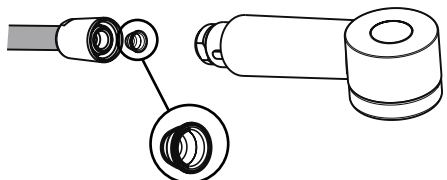

Replacement Parts

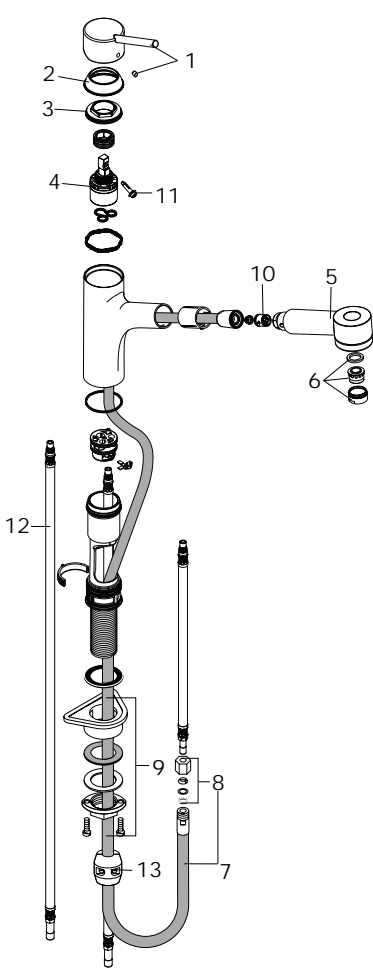

1	handle	32892XXX
2	nut cover	97995XXX
3	nut	97996000
4	cartridge	92730000
5	handspray	97999XXX
6	aerator	13912000
7	handspray hose	95048000
8	squeezing connection	96099000
9	mounting hardware	95049000
10	check valve	97350000
11	handle screw	96059000
12	supply hose	96316001
13	hose weight	98551000

XXX = color code
 001 = chrome
 801 = steel optik

Troubleshooting

Problem	Possible Cause	Solution
too little water	debris in hose filter kinked handspray hose	remove and clean hose filter straighten handspray hose
handle hard to turn	debris in aerator	clean aerator
faucet drips	cartridge dirty or faulty	replace cartridge
water on countertop at base of faucet	cartridge dirty or faulty	replace cartridge
water under sink	cartridge faulty	replace cartridge
	handspray hose connection loose	tighten hose to handspray
	cracked handspray	replace handspray
	pinhole in hose	replace hose

Cleaning Recommendation for Hansgrohe Products

Modern faucetry and shower products utilize a combination of materials to comply with the needs of the market with regard to design and functionality.

To avoid damage, it is necessary to use some caution when cleaning. Damage caused by improper treatment is not covered under the Hansgrohe warranty.

Cleaning Materials for Faucets and Showers

- To remove lime scale, use only products made specifically for that purpose. Always follow the manufacturer's instructions when using.
- Do not use cleaners that contain hydrochloric, formic, acetic, or phosphoric acids, as these will cause considerable damage to finishes and to plastic components.
- Never mix cleaning materials.
- Never use cleaners containing abrasives. Do not use abrasive cleaning cloths, pads, or sponges.

Cleaning Procedures

- Clean your faucets and shower products as and when required. Regular cleaning will prevent scale buildup and water spotting.
- Follow the label instructions. Do not allow any cleaner to remain on the product for longer than necessary.
- When using spray cleaners, spray first onto a sponge or cloth – do not spray directly onto the product.
- After cleaning, rinse thoroughly with clear water to remove any cleaner residue.

Important

- Soap and shampoo residue can also cause damage to the product. Rinse well with clean water after use.
- If the surface is already damaged, harsh cleaning materials will cause further damage.

Limited Lifetime Consumer Warranty

This product has been manufactured and tested to the highest quality standards by Hansgrohe, Inc. ("Hansgrohe"). This warranty is limited to Hansgrohe products which are purchased by a consumer in the United States after March 1, 1996 and installed in either the United States or Canada.

WHO IS COVERED BY THE WARRANTY

This warranty extends to the original consumer purchaser only.

WHAT IS COVERED BY THE WARRANTY

This warranty covers only your Hansgrohe manufactured product. Hansgrohe warrants this product against defects in material or workmanship as follows: Hansgrohe will repair at no charge for parts only or, at its option, replace any product or part of the product which proves defective because of improper workmanship and/or material, under normal installation, use, service and maintenance. If Hansgrohe is unable to provide a replacement and repair is not practical or cannot be timely made, Hansgrohe may elect to refund the purchase price in exchange for the return of the product.

LENGTH OF WARRANTY

Replacement or repaired parts of products will be covered for the term of this warranty as stated in the following two sentences. If you are a consumer who purchased the product for use primarily for personal, family, or household purposes, this warranty extends for as long as you own the product and the home in which the product is installed. If you purchased the product for use primarily for any other purpose, including, without limitation, a commercial purpose, this warranty extends only (i) for 1 year, with respect to Interaktiv and Retroaktiv products and (ii) for 5 years, with respect to AXOR, ShowerPower and Pharo products.

THIS WARRANTY DOES NOT COVER and HANSGROHE WILL NOT PAY FOR:

- A. Conditions, malfunctions or damage not resulting from defects in material or workmanship.
- B. Conditions, malfunctions or damage resulting from (1) improper installation, improper maintenance, misuse, abuse, negligence, accident or alteration, or (2) the use of abrasive or caustic cleaning agents or "no rinse" cleaning products, or the use of the product in any manner contrary to the product instructions.
- C. Labor or other expenses for the disconnection or return of the product for warranty service, or for installation or reinstallation of the product.
- D. Accessories or related products not manufactured by Hansgrohe.

TO OBTAIN WARRANTY SERVICE

Contact your Hansgrohe retailer, or write to Technical Service at:

Hansgrohe Inc.
1492 Bluegrass Lakes Parkway
Alpharetta GA 30004

Or, call Hansgrohe toll-free at (800) 334-0455.

In requesting warranty service, you will need to provide

- 1. The sales receipt or other evidence of the date and place of purchase.
- 2. A description of the problem.
- 3. Delivery of the product or the defective part, postage prepaid and carefully packed and insured, to Hansgrohe Inc. 1492 Bluegrass Lakes Parkway, Alpharetta, Georgia 30004, Attention: Technical Service, if required by Hansgrohe.

When warranty service is completed, any repaired or replacement product or part will be returned to you postage prepaid.

EXCLUSIONS AND LIMITATIONS

REPAIR OR REPLACEMENT (OR, IN LIMITED CIRCUMSTANCES, REFUND OF THE PURCHASE PRICE) AS PROVIDED UNDER THIS WARRANTY IS THE EXCLUSIVE REMEDY OF THE PURCHASER. HANSGROHE NEITHER ASSUMES NOR AUTHORIZES ANY PERSON TO CREATE FOR IT ANY OBLIGATION OR LIABILITY IN CONNECTION WITH THIS PRODUCT.

HANSGROHE SHALL NOT BE LIABLE TO PURCHASER OR ANY PERSON FOR ANY INCIDENTAL, SPECIAL, OR CONSEQUENTIAL DAMAGES, ARISING OUT OF BREACH OF THIS WARRANTY OR ANY IMPLIED WARRANTY (INCLUDING MERCHANTABILITY).

Some States do not allow the exclusion or limitation of incidental or consequential damages, so the above limitation or exclusion may not apply to you.

This warranty gives you specific legal rights and you may have other rights which vary from State to State.

You may be required by law to give us a reasonable opportunity to correct or cure any failure to comply before you can bring any action in court against us under the Magnuson-Moss Warranty Act.

PRODUCT INSTRUCTIONS AND QUESTIONS

Upon purchase or prior to installation, please carefully inspect your Hansgrohe product for any damage or visible defect. Prior to installing, always carefully study the enclosed instructions on the proper installation and the care and maintenance of the product. If you have questions at any time about the use, installation, or performance of your Hansgrohe product, or this warranty, please call or write to us at the toll-free number and address printed above.

hansgrohe

Hansgrohe, Inc. • 1490 Bluegrass Lakes Parkway • Alpharetta, GA 30004
Tel. 770 360-9880 • Fax 770 360 9887

www.hansgrohe-USA.com