

Installation Instructions / Warranty

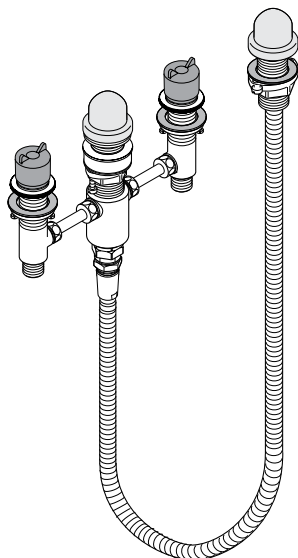

06646000

hansgrohe

4-Hole Roman Tub Rough

06646000

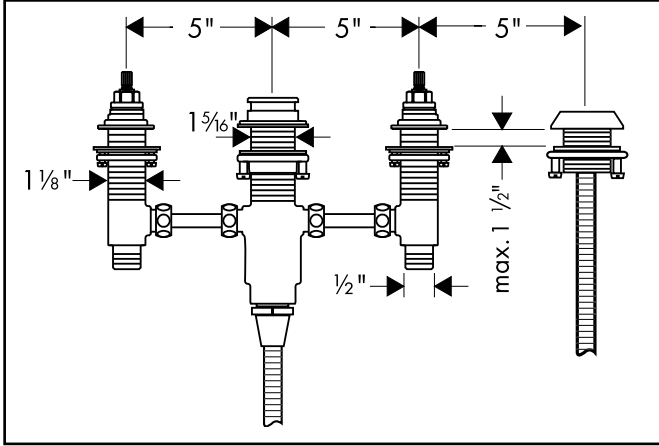

| | |
|------------------------------------|--------------------|
| Recommended operating pressure | 45 - 80 psi |
| Recommended hot water temperature | 120° - 140° F* |
| Flow rate - valves | approx. 6 gpm each |
| Hole sizes | |
| valves | 1 1/4" |
| spout | 1 3/8" |
| spout adapter pin | 3/16" |
| handshower holder | 1 1/2" |
| Maximum mounting surface thickness | 1 1/2" |

Protection against back siphonage provided by check valve included with the trim kit

This unit is listed by IAPMO, and is approved for use in Massachusetts.

*Please know and follow all applicable local plumbing codes when setting the temperature on the water heater.

Installation Considerations

- Hansgrohe recommends installation by a licensed professional plumber. Installation must be completed with a Hansgrohe Interaktiv or Retroaktiv 4-hole roman tub trim kit.
- Requires 1/2" supply lines (not included).
- Thoroughly flush the hot and cold supplies before installation of this valve.



To insure proper fit of the trim, the mounting surface must be complete before installation of this rough. The surfacing material (tile, etc.) MUST be installed.

- The included connecting tubes are type "K" copper tubing. If a non-standard installation is desired, the plumber may provide his own copper tubing.
- This unit is not anti-scald. If required by local plumbing code, install this unit in combination with an approved remote pressure balance valve or other approved device.

Installation

Install the connecting tubes to the valves and diverter housing with the enclosed $\frac{3}{8}$ " compression fittings.

Remove the plaster shields, mounting rings and stop rings from the valves. Remove the plaster shield, plug, spout adapter and sealing ring from the diverter housing.

* **The spacer may be removed and discarded if there is insufficient space.**

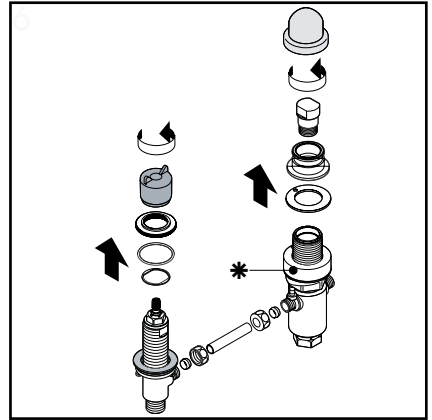

! **To insure proper fit of the trim, do not install this valve until after the surface material (tile, etc.) is installed.**

Insert the valves and diverter housing through the holes in the mounting surface with the hot valve on the left, cold valve on the right.

Install the stop rings and mounting rings on the valves. The stop rings will stop the mounting rings at the correct mounting height.

Install the sealing ring and spout adapter on the diverter housing.

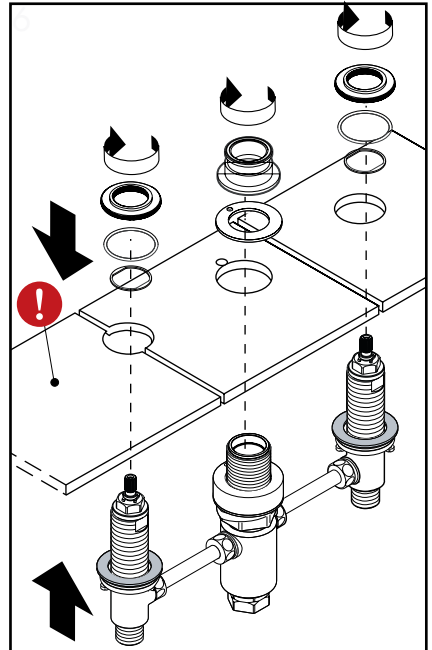

Rest the assembly on the mounting surface, with the spout adapter pin inserted in its hole.

Tighten the mounting nuts and tensioning screws.

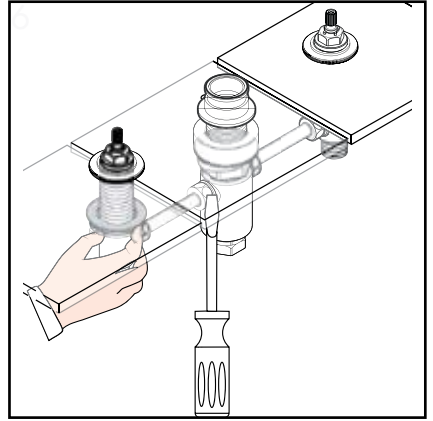

Remove the plug from the bottom of the diverter housing.

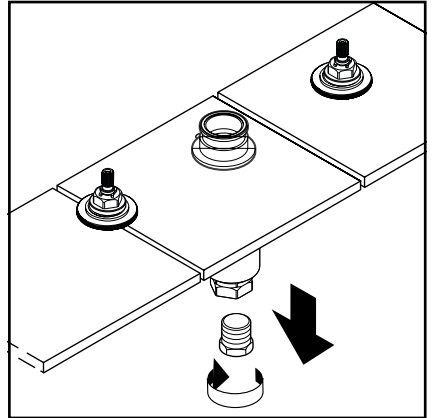

Install the hose adapter.

Screw one end of the handshower hose to the adapter.

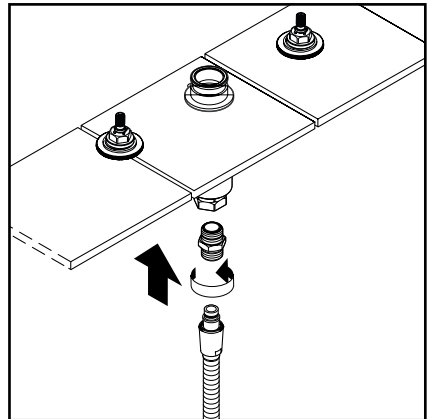

Place the handshower holder and sealing ring in the hole on the mounting surface.

Install the friction washer, metal washer and mounting nut. Tighten the tensioning screws.

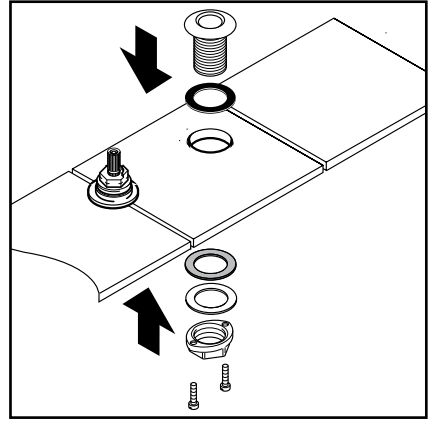

Push the hose up through the handshower holder.

Snap the two halves of the handshower holder insert around the hose.

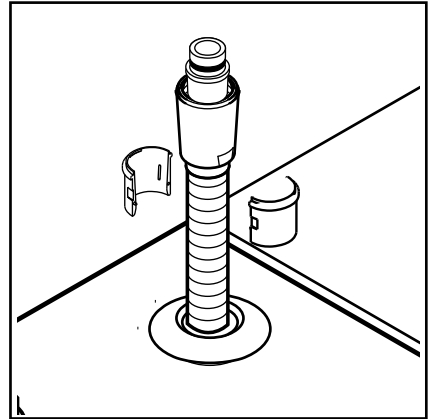

Install the hot and cold supply lines (not included).

If the trim is not to be installed immediately, replace the diverter housing plug and the plaster shields.

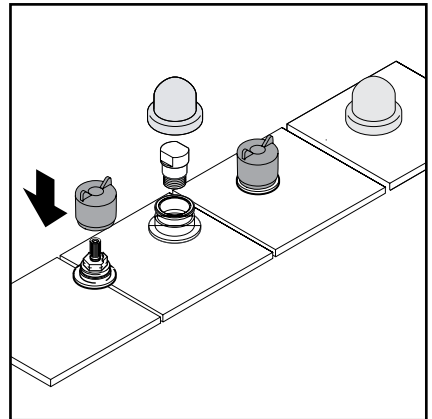

Replacement Parts

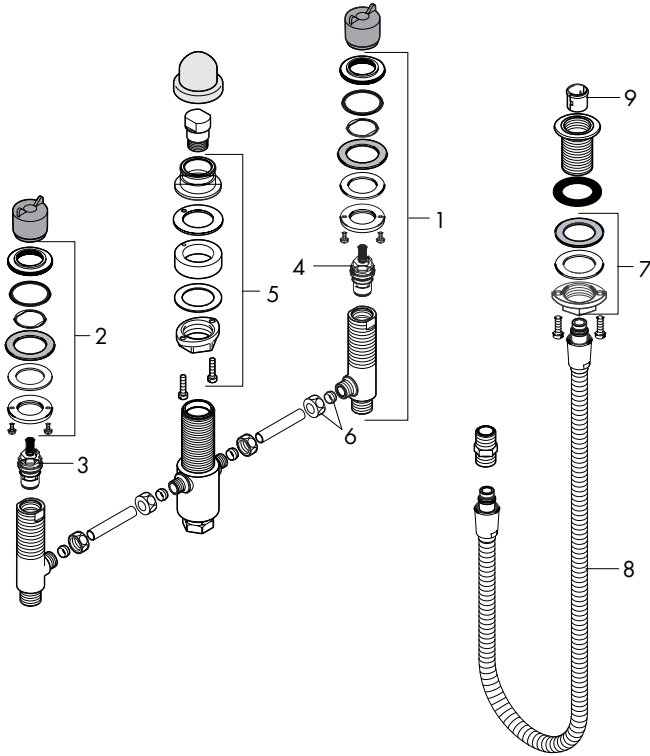

| | | |
|---|--------------------------|----------|
| 1 | deck valve set | 88503000 |
| 2 | mounting set | 88511000 |
| 3 | hot cartridge | 94009000 |
| 4 | cold cartridge | 94008000 |
| 5 | mounting set | 96080000 |
| 6 | 3/8" compression fitting | 88513000 |
| 7 | mounting set | 13961000 |
| 8 | handshower hose | 97161000 |
| 9 | handshower holder insert | 96942000 |

Cleaning Recommendation for Hansgrohe Products

Modern lavatory faucets, kitchen faucets, and showers consist of very different materials to comply with the needs of the market with regard to design and functionality. To avoid damage and returns, it is necessary to consider certain criteria when cleaning.

Cleaning Materials for Faucets and Showers

Acids are a necessary ingredient of cleaning materials for removing lime, however please pay attention to the following points when cleaning faucets and showers:

- Only use cleaning materials which are explicitly intended for this type of application.
- Never use cleaning materials which contain hydrochloric, formic, phosphoric, or acetic acid, as they cause considerable damage.
- Never mix one cleaning material with another.
- Never use cleaning materials or appliances with an abrasive effect, such as unsuitable cleaning powders, sponge pads, or micro fiber cloths.

Cleaning Instructions for Faucets and Showers

Please follow the cleaning material manufacturer's instructions. In addition, pay attention to the following points:

- Clean the faucets and showers as and when required
- Use the amount of cleaning product and the amount of time recommended by the manufacturer. Do not leave the cleaner on the fixture longer than necessary.
- Regular cleaning can prevent calcification.
- When using spray cleaners, spray first onto a soft cloth or sponge. Never spray directly onto the faucet as droplets can enter openings and gaps and cause damage.
- After cleaning, rinse thoroughly with clean water to remove any cleaner residue.

Important

Residues of liquid soaps, shampoos, and shower foams can also cause damage, so rinse with clean water after using.

Please note: if the surface is already damaged, the effect of cleaning materials will cause further damage.

Components with damaged surfaces must be replaced or injury could result.

Damage caused by improper treatment is not covered under the warranty.

Limited Lifetime Consumer Warranty

This product has been manufactured and tested to the highest quality standards by Hansgrohe, Inc. ("Hansgrohe"). This warranty is limited to Hansgrohe products which are purchased by a consumer in the United States after March 1, 1996, and installed in either the United States or Canada.

WHO IS COVERED BY THE WARRANTY

This warranty extends to the original consumer purchaser only. This warranty is non-transferable.

WHAT IS COVERED BY THE WARRANTY

This warranty covers only your Hansgrohe manufactured product. Hansgrohe warrants this product against defects in material or workmanship as follows: Hansgrohe will repair at no charge for parts only or, at its option, replace any product or part of the product that proves defective because of improper workmanship and/or material, under normal installation, use, service and maintenance. If Hansgrohe is unable to provide a replacement and repair is not practical or cannot be timely made, Hansgrohe may elect to refund the purchase price in exchange for the return of the product.

LENGTH OF WARRANTY

Replacement or repaired parts of products will be covered for the term of this warranty as stated in the following two sentences. If you are a consumer who purchased the product for use primarily for personal, family, or household purposes, this warranty extends for as long as you own the product and the home in which the product is originally installed. If you purchased the product for use primarily for any other pur-

pose, including, without limitation, a commercial purpose, this warranty extends only (i) for 1 year, with respect to Hansgrohe and Commercial products, and (ii) for 5 years, with respect to AXOR products.

THIS WARRANTY DOES NOT COVER, AND HANSGRÖHE WILL NOT PAY FOR:

- A. Conditions, malfunctions or damage not resulting from defects in material or workmanship.
- B. Conditions, malfunctions or damage resulting from (1) normal wear and tear, improper installation, improper maintenance, misuse, abuse, negligence, accident or alteration, or (2) the use of abrasive or caustic cleaning agents or “no-rinse” cleaning products, or the use of the product in any manner contrary to the product instructions. (3) Conditions in the home such as excessive water pressure or corrosion.
- C. Labor or other expenses for the disconnection, deinstallation, or return of the product for warranty service, or for installation or reinstallation of the product (including but not limited to proper packaging and shipping costs), or for installation or reinstallation of the product.
- D. Accessories, connected materials and products, or related products not manufactured by Hansgrohe.

TO OBTAIN WARRANTY PARTS OR INFORMATION

Contact your Hansgrohe retailer, or contact Technical Service at:

Hansgrohe Inc.
1492 Bluegrass Lakes Parkway
Alpharetta GA 30004
Toll-free (800) 334-0455.

In requesting warranty service, you will need to provide

- 1. The sales receipt or other evidence of the date and place of purchase.
- 2. A description of the problem.
- 3. Delivery of the product or the defective part, postage prepaid and carefully packed and insured, to Hansgrohe Inc. 1492 Bluegrass Lakes Parkway, Alpharetta, Georgia 30004, Attention: Technical Service, if required by Hansgrohe.

When warranty service is completed, any repaired or replacement product or part will be returned to you postage prepaid.

EXCLUSIONS AND LIMITATIONS

REPAIR OR REPLACEMENT (OR, IN LIMITED CIRCUMSTANCES, REFUND OF THE PURCHASE PRICE) AS PROVIDED UNDER THIS WARRANTY IS THE EXCLUSIVE REMEDY OF THE PURCHASER. HANSGRÖHE NEITHER ASSUMES NOR AUTHORIZES ANY PERSON TO CREATE FOR IT ANY OBLIGATION OR LIABILITY IN CONNECTION WITH THIS PRODUCT.

HANSGRÖHE SHALL NOT BE LIABLE TO PURCHASER OR ANY PERSON FOR ANY INCIDENTAL, SPECIAL, OR CONSEQUENTIAL DAMAGES, ARISING OUT OF BREACH OF THIS WARRANTY OR ANY IMPLIED WARRANTY (INCLUDING MERCHANTABILITY).

Some States do not allow the exclusion or limitation of incidental or consequential damages, so the above limitation or exclusion may not apply to you. This warranty gives you specific legal rights, and you may have other rights which vary from State to State. You may be required by law to give us a reasonable opportunity to correct or cure any failure to comply before you can bring any action in court against us under the Magnuson-Moss Warranty Act.

PRODUCT INSTRUCTIONS AND QUESTIONS

Upon purchase or prior to installation, please carefully inspect your Hansgrohe product for any damage or visible defect. Prior to installing, always carefully study the enclosed instructions on the proper installation and the care and maintenance of the product. If you have questions at any time about the use, installation, or performance of your Hansgrohe product, or this warranty, please call or write to us or call us toll-free at 800 334 0455.

hansgrohe

Hansgrohe, Inc. • 1490 Bluegrass Lakes Parkway • Alpharetta, GA 30004
Tel. 770-360-9880 • Fax 770-360-9887

www.hansgrohe-usa.com