

DESCRIPTION

- Brass construction with chrome plated finish
- 1/2" IPS connections
- Vandal resistant torx head screws

OPERATION

- Wristblade handles with hot and cold color indicators
- Vandal resistant torx head screws

FLOW

- Vandal resistant torx flow aerator
- Aerator is limited to 2.2 GPM max (8.3L /min)

CARTRIDGE

- Brass shell, ceramic disc cartridge
- 1/4 turn operation

STANDARDS

- Third party certified to meet ASME A112.18.1/CSA B125.1 and all applicable specifications referenced therein
- Contains no more than 0.25% weighted average lead content
- Certified to NSF 61/9
- Complies with California Proposition 65 and with the Federal Safe Drinking Water Act

- **ADA**  for lever handles

WARRANTY

- Warranted for five years against material or manufacturing defects

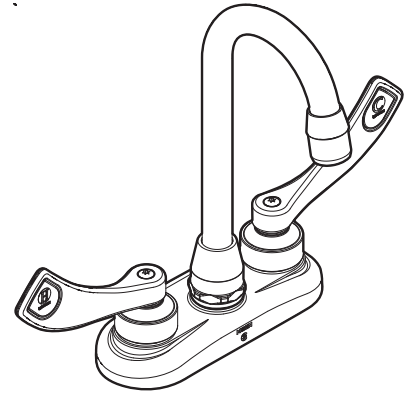

Two-Handle Bar/Pantry Faucet

Model: 8278



NOTE: Designed to be installed through 2 holes - 1" min. dia.

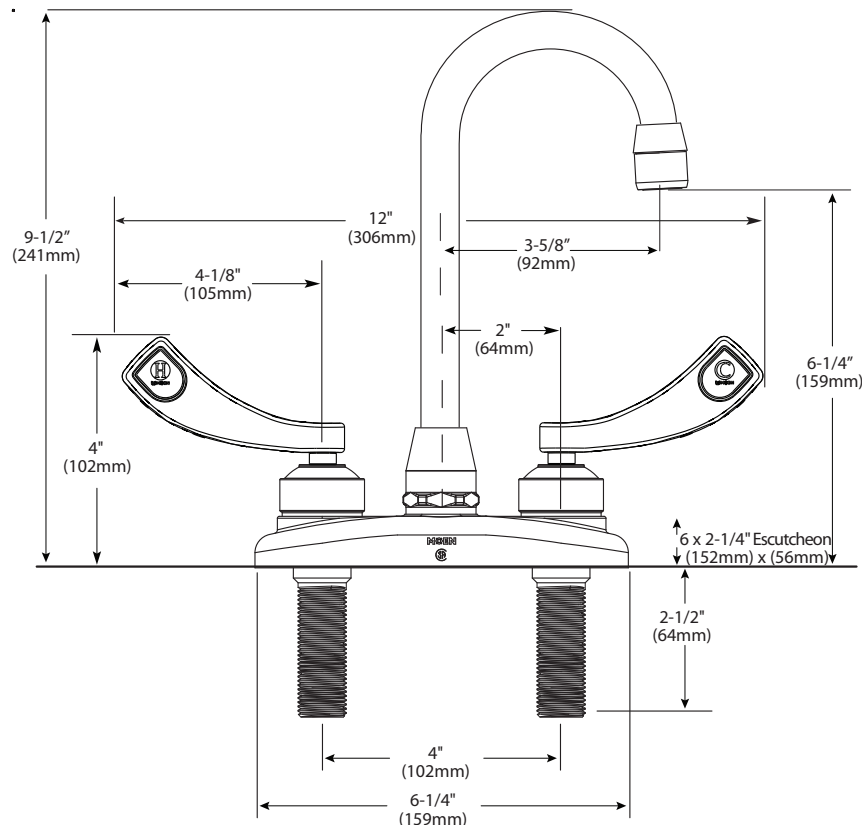

CRITICAL DIMENSIONS

(DO NOT SCALE)