

## DESCRIPTION

- Brass construction
- For installations from 8" (203mm) to 10" (254mm) centers
- Designed to be installed on decks up to 2-1/8" (54mm)
- The tub fill spout is a slip fit design and the supplies are 1/2" type K, copper tubing

## OPERATION

- Shown here with lever style handles, can be installed with any Moen Deck Mounted Roman Tub Trim Kit
- Rotate hot side handle counterclockwise to open (clockwise to close) and the cold side handle (clockwise to open) and (counterclockwise to close)

## FLOW

- Designed to deliver 18 gpm at 40 psi.

## CARTRIDGE

- Nonmetallic and stainless steel materials

## STANDARDS

- Designed and manufactured to comply with the applicable requirements of: CSA B-125 and ASME A112.18.1M and all applicable requirements referenced therein

## WARRANTY

- Lifetime limited warranty against leaks, drips and finish defects to the original consumer purchaser
- 5 year warranty if used in commercial installations

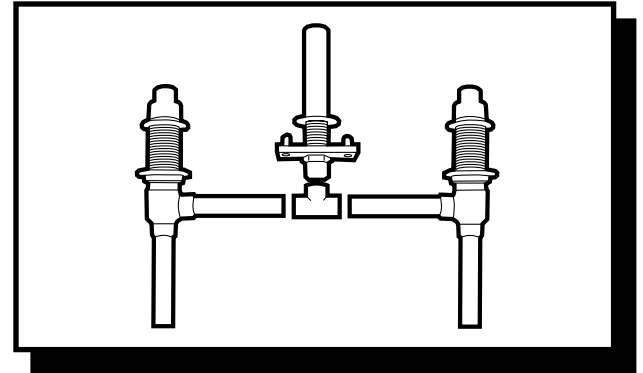

**Roman Tub High Flow Rough-In Valve  
(Adjustable Type)**

**Models: 4999 or 64999  
(64999 is bulk packed 12 per carton)  
(Shown below with MONTICELLO® Trim)**

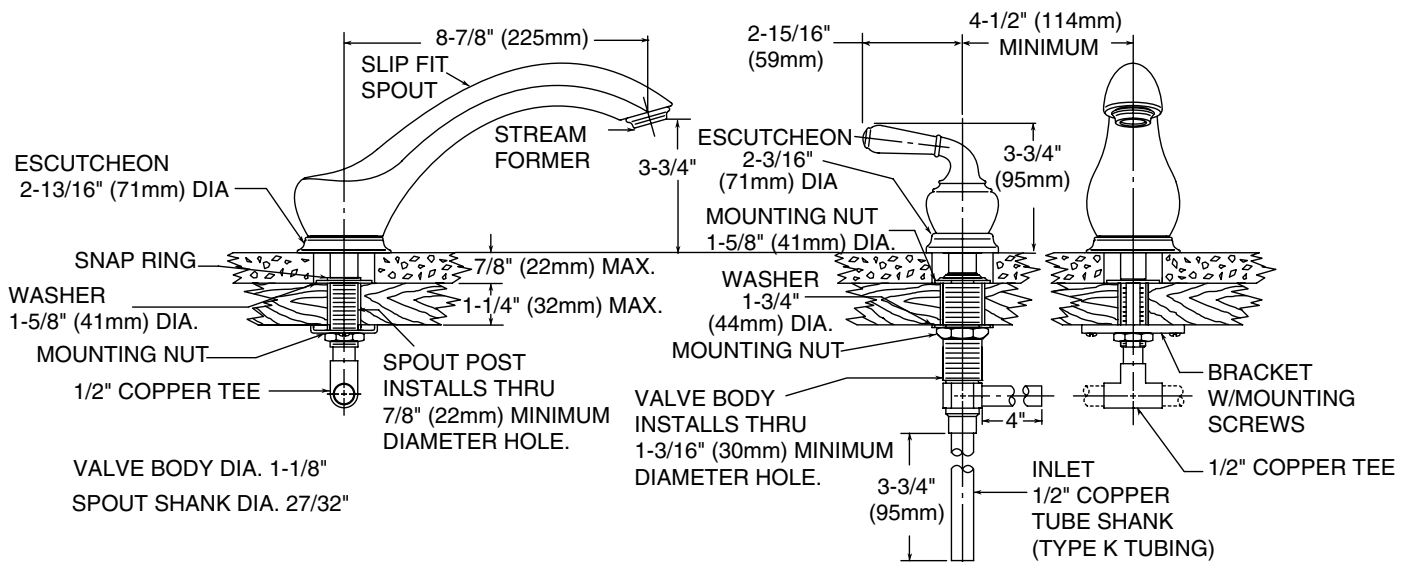

**NOTE: THE INSTALLATION SHOWN IS FOR TILE DECKS, THIS VALVE WILL ALSO FIT STEEL, CAST IRON OR PLASTIC DECKS**

## **CRITICAL DIMENSIONS**

(DO NOT SCALE)