

Installation and Care Guide

Bath with Airjets

Save These Instructions
Conserver ces instructions
Guarde estas instrucciones

Retain serial number for reference:

Numéro de série du produit:

Número de serie del producto: _____

Français, page "Français-1"

Español, página "Español-1"

THE BOLD LOOK
OF **KOHLER**®

Installation Instructions



WARNING: When using electrical products, basic precautions should always be followed, including the following:



DANGER: Risk of electric shock. Connect only to a circuit protected by a Ground-Fault Circuit-Interrupter (GFCI)*.

Building materials and wiring should be routed away from the blower body and other heat-producing components of the unit.

Install to permit access for servicing.

A pressure wire connector marked "Earth/Ground" is provided within the wiring compartment. To reduce the risk of electric shock, connect this connector to the grounding terminal of your electric service or supply panel with copper wire equivalent in size to the circuit conductor supplying this equipment.

Pressure wire connectors are provided on the exterior of the junction box or control within this unit to permit connection of a bonding conductor between this unit and all other exposed metal in the vicinity, as needed to comply with local requirements.

An equipment grounding terminal is provided in the field wiring compartment. To reduce the risk of electric shock, this terminal must be connected to the grounding means provided in the electric supply panel with a conductor equivalent in size to the circuit conductors supplying this equipment.

Grounding is required. The unit should be installed by a qualified service representative, and grounded.



WARNING: Risk of injury or property damage. Please read all instructions thoroughly before beginning installation, including the following requirements.



WARNING: Risk of electric shock. A qualified electrician should make all electrical connections.



WARNING: Risk of electric shock. Disconnect power before servicing.

NOTICE: Follow all local plumbing and electrical codes. In Canada, install this unit in accordance with the Canadian Electrical Code, Part 1.

*Outside North America, this device may be known as a Residual Current Device (RCD).

Product Information

Electrical Requirements

The installation must have a Class A Ground-Fault Circuit-Interrupter (GFCI) or Residual Current Device (RCD). The GFCI or RCD protects against line-to-ground shock hazards. **Use a 220 - 240 V, 20 A, 50/60 Hz dedicated service for the bath.**

Product Notices



WARNING: Risk of personal injury or property damage. Unauthorized modification may cause unsafe operation or affect performance of the bath. Do not relocate the blower motor, or make other modifications to the bath system in the absence of kit or other published instructions, as this could adversely affect the performance and safe operation of the product. Kohler Co. shall not be liable under its warranty or otherwise for personal injury or damage caused by any such unauthorized modification. Refer to the "Prepare the Blower (Remote Site)" section for blower motor relocation requirements, recommendations, and section coverage information.

NOTICE: Keep the area around the blower motor clean and free of debris. Ensure that the area around the blower motor is free of sawdust, insulation, dirt, or other small loose debris. Such material could plug the blower motor air intake and reduce the air flow through the blower.

Product Information (cont.)

Features

Factory assembled components include a blower motor, air harness, control, check valve, butterfly valves, chromotherapy lights (if provided), electrical harnesses, and an illuminated user keypad. Other than power wiring and plumbing, no assembly is required.

Tools and Materials

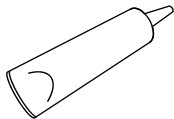

Silicone Sealant



Measuring Tape



Pencil

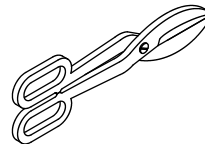

Tin Snips

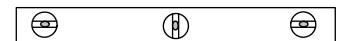

Level



Safety Glasses

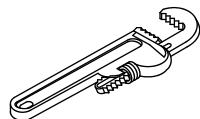

Pipe Wrench

Plus:

- Conventional woodworking tools and materials
- Drop cloth
- Metal shims
- 2x4s

Prepare the Blower (Remote Site)

NOTICE: The blower motor and the check valve must be relocated together. Do not relocate one without the other.

NOTE: This bath can be installed as received or with the blower motor and check valve relocated to another location. Refer to the appropriate sections throughout this manual for instructions related to your particular installation. Read this section before relocating your blower.

- Relocate the blower and check valve as close as possible to the bath to maximize performance. Do not relocate the blower and check valve more than 15' (4.5 m) from the bath.
- Position the blower 1-1/2" (38 mm) above the floor. Do not mount the blower motor with the blower motor discharge pointing up.
- Use 1-1/2" PVC or equivalent rigid piping.
- The piping installation must meet the requirements of local plumbing or building codes. Ensure that the installation does not reduce the fire rating of any walls. Piping must be supported at intervals along the length in accordance with local codes.
- Ensure that the blower motor location is clean and free of dust or debris.
- Install an access panel for blower motor maintenance.
- The 18 AWG minimum power cable to the blower motor must meet the requirements of all applicable electrical or building codes. Ensure that the installation does not reduce the fire rating of any walls.
- The power cord must be supported at intervals along its length in accordance with local codes. Power cords must not rest on surfaces or floors that are subject to flooding.
- All material needed for the relocation must be supplied by the installer.
- Additional tools and materials you will need:

Prepare the Blower (Remote Site) (cont.)

- Electrician pliers
- Assorted screwdrivers
- Adjustable wrench
- Drill and bits to install the blower mounting fasteners
- 18 AWG non-metallic sheathed cable, two conductors with ground, with support clips, as required
- One 4" (102 mm) x 2" (51 mm) electrical junction box with cover, gasket, and mounting screws
- Three strain reliefs - one must fit the blower motor cover with standard National Pipe Thread (NPT) threads. The other two must fit the holes in the new junction box.
- Six wire connectors (wire nuts or equivalent)
- 1-1/2" PVC or other rigid pipe with fittings, unions, PVC cement (or equivalent fastening method), and support clips, as required
- Four fasteners (such as flathead wood screws or concrete anchors) to secure the blower motor
- Solid copper 8-gauge bonding wire, 36" (914 mm)

Alcove

Position the rough plumbing.

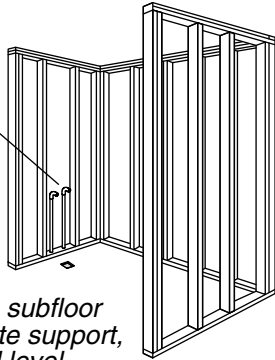

Construct 2x4 stud framing according to the roughing-in information.

Verify that the subfloor offers adequate support, and is flat and level.

Drop-In

Position the rough plumbing.

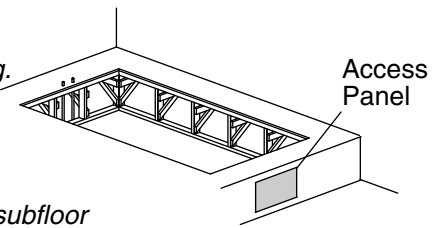

Construct according to the product dimensions.

Verify that the subfloor offers adequate support, and is flat and level.

1. Prepare the Site



WARNING: Risk of personal injury. This cast iron bath is extremely heavy. Obtain sufficient help to carefully lift and move it.

NOTICE: Measure your product for site preparation. Note the **model number** located on the blower, then visit the product page at www.kohler.com for more information.

NOTICE: Provide adequate ventilation and a minimum 15 cubic feet (.4 cubic meters) air space in the installed location for cooling the motor and to supply sufficient air for the blower. Do not install the blower motor closer than 1" (25 mm) from the wall or other objects.

NOTICE: Provide generous, unrestricted access to the blower. You must provide access for servicing the blower and controls. The access must be located immediately next to the blower.

NOTICE: Do not lift the bath by the piping or blower, or use the piping or blower for structural support of the bath. To avoid damage to the bath, lift at the sides of the bath.

NOTICE: Do not support the weight of the bath by the rim.

NOTE: Drop-in, alcove, or corner installation is possible, depending on the product chosen.

- Carefully unpack and inspect the new bath for damage before installation. If there is damage do not install the bath; contact your dealer.
- Make sure the flooring offers adequate support for your bath, and verify that the subfloor is flat and level.
- Construct 2x4 stud framing.
- Install an access panel for future blower servicing. The access panel must be at least 34" (864 mm) wide by 15" (381 mm) high.
- Install the rough plumbing.
- Install the drain to the bath according to the drain manufacturer's instructions.
- Protect the bath surface by positioning a clean drop cloth in the basin bottom.

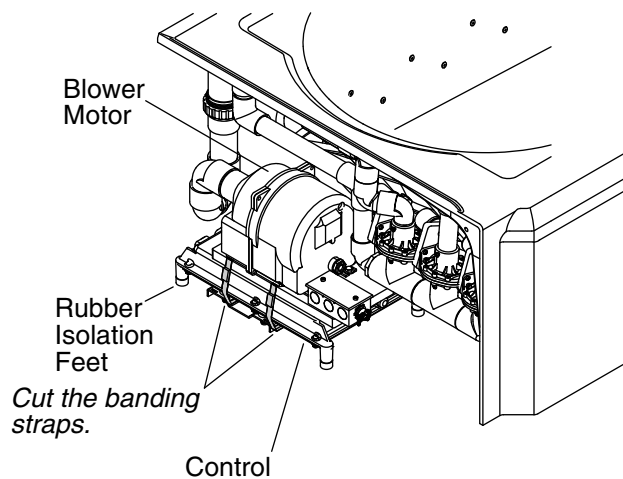
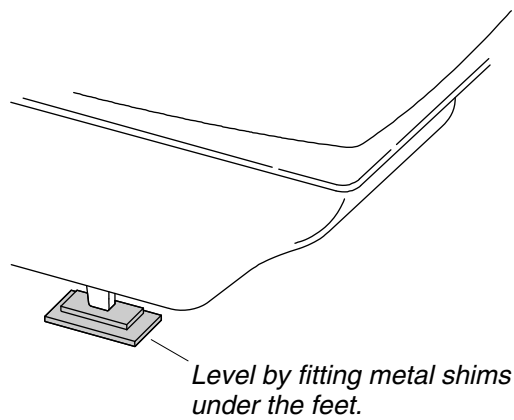

2. Install the Bath



WARNING: Risk of personal injury. This cast iron bath is extremely heavy. Obtain sufficient help to carefully lift and move it.

NOTICE: Do not lift the bath by the piping or blower, or use the piping or blower for structural support of the bath. To avoid damage to the bath, lift by the rim at the sides of the bath.

- Carefully move the bath into position.
- Level the bath by fitting metal shims under the feet as needed. Check for level along the rim. Make sure the bath is resting on all four feet.

Cut the Banding Straps

IMPORTANT! This step is necessary to make the bath operate more quietly.

- Cut the two banding straps from the blower.

Install the Plumbing

- Insert the drain tailpiece into the trap. Secure the drain tailpiece to the trap.
- Install the faucet valve.
- Check the drain connections for leakage.

Bond in accordance with national and local codes. Open bonding lugs are located at the top of the junction box.

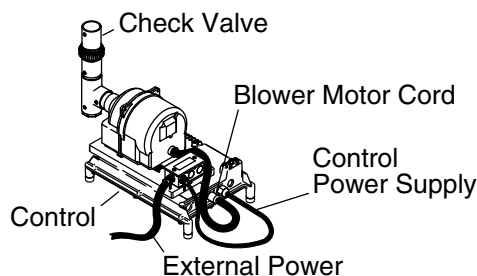

Typical Wiring Connection for North America

* Connections to be Made at the Circuit Breaker

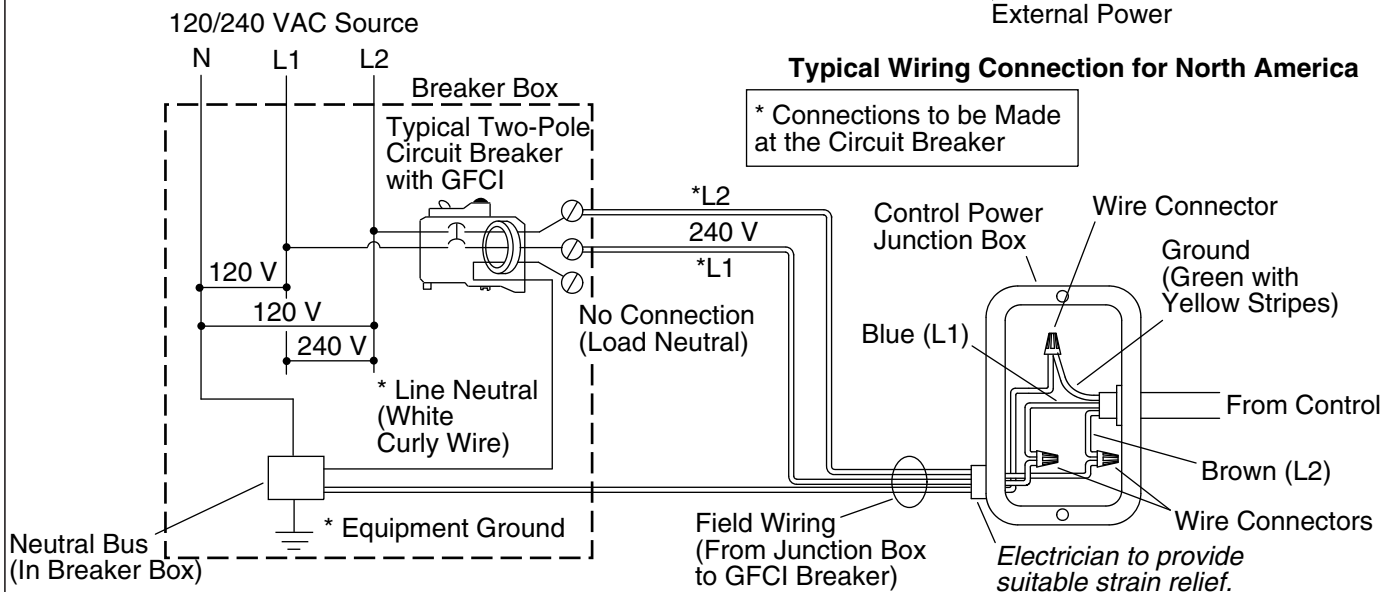

3. Make Electrical Connections - Standard

NOTE: The product model number is printed on a label on the blower side of the bath. This label also identifies the electrical rating of the product. All baths come equipped with a wiring junction box and are designed to operate between 220 V and 240 V at either 50 Hz or 60 Hz.



WARNING: Risk of electrical shock. Make sure the power has been disconnected before performing the following procedures.



WARNING: Risk of electrical shock. Connect the blower to a properly grounded Ground-Fault Circuit-Interrupter (GFCI) or Residual Current Device (RCD). This will provide additional protection against line-to-ground shock hazard. A 220-240 V, 20 A, 50/60 Hz dedicated circuit is required.

IMPORTANT! The **load neutral** is not used. There should be no connection to the **load neutral** terminal on the Ground-Fault Circuit-Interrupter (GFCI) breaker. The green wire with the yellow stripe is the **equipment ground** and needs to be connected to the neutral bus in the main circuit breaker box.

NOTE: The wiring harness includes an antenna for the optional remote control. Do not alter or damage this antenna during installation.

- Connect service to the junction box. The junction box contains blue, brown, and green with a yellow stripe colored wires and a ground lug
- Follow local electrical codes. Bond in accordance with national and local codes.

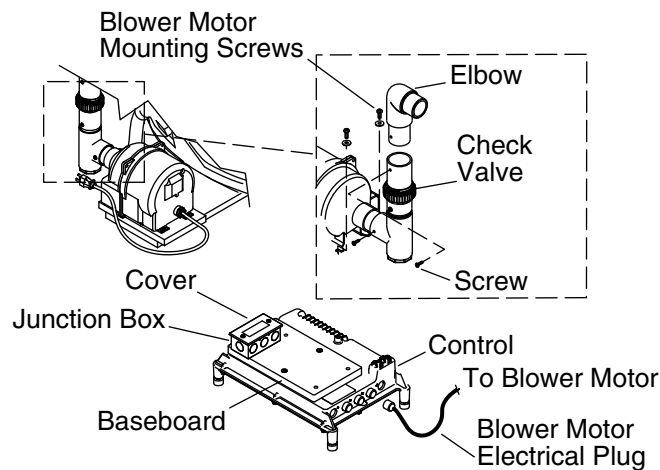

4. Disconnect the Blower Motor - Remote

NOTICE: This section applies only to installations in which the blower motor and check valve are being relocated.

NOTICE: Do not cut the blower piping for this installation.

NOTICE: You must relocate the check valve with the blower motor. Do not disconnect the check valve from the tee.

Remove the Blower Motor and Check Valve

- Disconnect the blower motor electrical plug from the control.
- Remove any cable ties that support the blower motor cord.
- Remove and retain the screw holding the check valve to the PVC elbow.
- Remove and retain the four screws from the baseboard.
- Slide the blower motor and check valve away from the elbow, and remove the blower motor from the bath.

Prepare the Site

NOTE: Refer to the "Prepare the Blower (Remote Site)" section for blower relocation details.

- Prepare the site where the blower motor will be installed. The site must be within 15' (4.5 m) of the bath.
- Install an access panel to service the blower motor.
- Prepare the routing paths for the PVC piping and the new blower motor power cable. Follow all applicable codes.

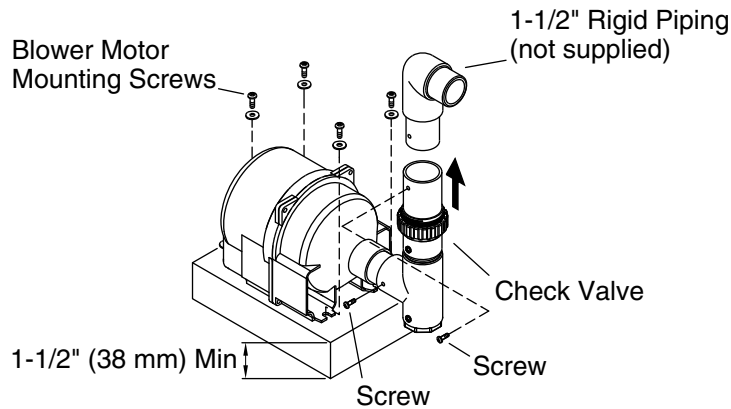

5. Mount the Blower Motor and Check Valve - Remote

NOTE: The blower motor must be mounted horizontally 1-1/2" (38 mm) above the floor. Do not mount the blower motor with the discharge pointing up.

NOTE: Refer to the "Prepare the Blower (Remote Site)" section for other requirements for the blower motor relocation.

- At the new blower motor location, install a 1-1/2" (38 mm) high block (not supplied) to support the blower motor.
- Use the blower motor as a template to mark the location of the four mounting bolts or screws.
- Drill four 1/8" (3 mm) pilot holes for the blower motor mounting screws.
- Install and support PVC or other 1-1/2" rigid piping (not supplied) between the blower motor location and the air harness.
- Connect the new piping to the existing air harness without modifying the air harness. Align the new pipe and secure the connection with PVC cement. **Allow the PVC cement to cure according to the manufacturer's instructions.**
- Connect the check valve assembly to the new piping. Align the new pipe with the check valve assembly and drill a hole for the existing mounting screw. Use silicone or equivalent sealant at the connections and reuse the screw that was removed previously. Allow the sealant to cure according to the manufacturer's recommendations.
- Position the motor on the support block. Reinstall the screw on the check valve.
- Fasten the blower motor to the new support block with the mounting screws.

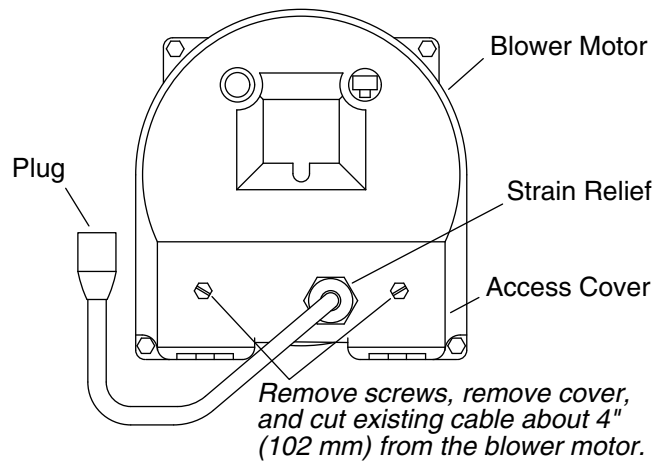

6. Terminate the Cable at the Blower - Remote

Route the Power Cable

- Route 18 AWG or equivalent power cable (two conductors with ground) between the bath and blower. Support and protect the cable. Follow local electrical codes.

Prepare the Blower for Remote Installation

- Loosen the cable strain-relief nut on the blower motor. Push the nut back on the cable to provide clearance for the cover removal.
- Remove and retain the two access cover screws from the back of the blower motor. As you are loosening the screws, check periodically if the cover can be slid back on the electrical cable.
- When the cover is loose, use electrician pliers or equivalent to cut the electrical cable at a point about 4" (102 mm) from where the cable enters into the blower motor housing.
- Pull the free end of the electrical cord through the cover, insert, and strain relief nut.
- Discard the existing strain relief nut and insert.
- Reconnect the blower motor plug to the control.
- Install a standard NPT threaded strain relief to the blower motor cover.

Connect the New Power Cable at the Blower Motor

- On the 4" (102 mm) pigtail lead of the blower motor, strip back the cable jacket about 3" (76 mm).
- On the customer-supplied power cable, strip back the cable jacket about 2" (51 mm).
- In the USA, mark white conductors with red or black tape as required by the National Electric Code (NEC).
- Strip the wire insulation 3/8" (10 mm) from the blower motor pigtail and power cable leads.
- Route the new power cable leads through the blower motor access cover and strain relief.
- Using wire nuts or other approved termination methods, terminate the conductors as follows:
 - Connect the black pigtail lead to the L1 conductor of the power cable.
 - Connect the blue pigtail lead to the L2 or N conductor of the power cable.
 - Connect the green with yellow stripe pigtail lead to the power cable ground conductor.
- With the two screws, reinstall the access cover on the blower motor.
- Tighten the strain relief on the power cable at the blower motor.
- Remove any dust or debris from the blower motor area.

Second Junction Box

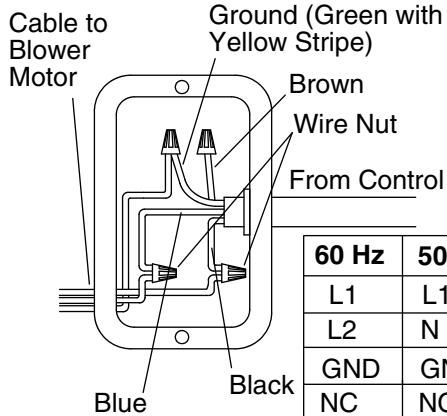

Strip back the jackets about 3" (76 mm) on the field cable and on the blower motor pigtail. Then cut the unused fourth conductor brown wire off at the point that the cable jacket ends.

60 Hz	50 Hz	From Control
L1	L1	Black
L2	N	Blue
GND	GND	Green w/Yellow Stripe
NC	NC	Brown

Control Power Junction Box

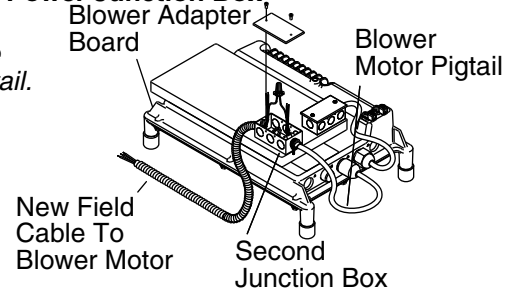

Route the cut end of the cord to the new junction box. Add strain relief. Install junction box with cover and bonding lug (not provided).

7. Install the Blower Cord at the Control - Remote

Install the Second Junction Box on the Control

- Install a second junction box with external bonding lug, two strain reliefs, and a cover (not supplied) on the blower adapter board on the control.
- Connect a solid copper 8-gauge bonding wire from the bonding lug on the new junction box to the spare bonding lug on the control. Follow all local electrical codes.

Reconnect the Blower Motor Power Cord

- If required, reconnect the blower motor power cord at the control.
- Route the blower motor power cord through a strain relief on the second junction box. Tighten the strain relief.
- At the end of the cut power cord, strip back the cable jacket about 3" (76 mm).
- Using a wire nut, cap off the unused brown conductor in the cable jacket.
- Strip about 3/8" (10 mm) of wire insulation from the remaining control wires.

Reconnect the Blower New Power Cable

- Route the customer-supplied power cable from the blower through the other strain relief on the second junction box. Tighten the strain relief.
- Strip back the cable jacket about 3" (76 mm).
- For installations in the USA, mark the white wire with either red or black electrical tape as required by the National Electric Code (NEC).
- Strip the end of the wires about 3/8" (10 mm).
- Use approved termination devices to terminate the conductors as follows:
 - Connect the black pigtail lead to the L1 conductor of the power cable.
 - Connect the blue pigtail lead to the L2 or N conductor of the power cable.
 - Connect the green with yellow stripe pigtail lead to the grounding or earthing conductor of the power cable.
 - The brown wire is not used and should be capped with a wire nut.
- Install the cover on the new junction box.

Typical Remote Blower Installation

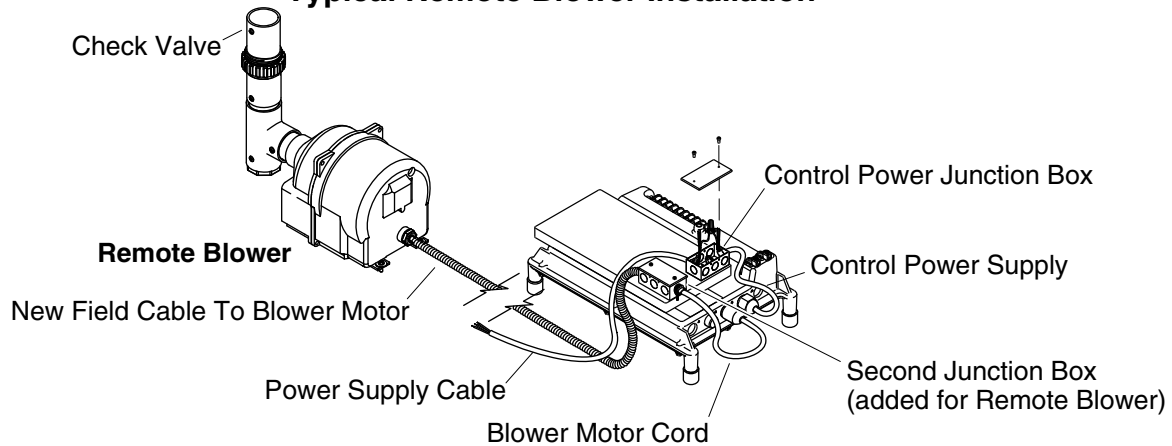

8. Make Power Connections - Remote



WARNING: Risk of electric shock. To reduce the risk of electric shock, connect the control to a properly grounded Ground-Fault Circuit-Interrupter (GFCI) or Residual Current Device (RCD). This will provide additional protection against line-to-ground shock hazard. A dedicated 220-240 V, 20 A, 50/60 Hz circuit is required.



WARNING: Risk of electric shock. Make sure the power has been disconnected before performing the following procedures.

- Ensure that the control power supply cord is properly routed to the control power junction box. The control power supply cord contains a brown wire (Line 1), a blue wire (Line 2), and a green wire with a yellow stripe (ground or earth).
- Install a strain relief (not provided) for the power supply cable to the control power junction box.
- Route the power supply cable to the control power junction box.
- As required, strip the jacket and wire insulation on both cables to make the connections.
- For installations in the USA, mark any white conductor in the supply power wiring with red or black tape as required by the NEC.
- Connect service to the control power junction box.
- Provide a separate equipment earthing or grounding conductor to the spare earth/ground lug located on the control power junction box. This conductor **must not** be connected to any current-carrying conductor. Follow local electrical codes.
- Bond in accordance with national and local codes.
- Clean the area of all dust and debris.
- All wiring harnesses have been pre-wired at the factory. Ensure that all wires are securely fastened.

NOTE: Your wiring harness includes an antenna for the optional remote control. Do not alter or damage this antenna during installation.

9. Complete the Installation

Test Run the Bath

- Fill the bath to a level at least 4" (102 mm) above the top of the highest airjet.
- Operate the bath for 5 minutes and check all bath piping connections for leaks. Check for leakage along the front, sides, and back of the bath.
- For additional information on bath operation, see the "Operating Instructions" section.

Complete the Installation (cont.)

Finish the Installation

- Install water-resistant wallboard and all finished wall, deck, and floor materials.
- Apply silicone sealant to seal all areas where the bath and finished wall or deck meet.
- Install the faucet trim.

Clean-up After Installation

- When cleaning up after installation, **do not use abrasive cleansers**, as they may scratch and dull the bath surface. Use warm water and a liquid detergent to clean the surface of the bath.
- Remove stubborn stains or paint with turpentine or paint thinner. **Do not allow cleaners containing petroleum distillates to remain in contact with any bath surface for long periods of time.** Remove plaster by carefully scraping with a wood edge. Do not use metal scrapers, wire brushes, or other metal tools. Use a powder-type detergent on a damp cloth to provide mild abrasive action to any residual plaster.

Important Safety Instructions

READ AND FOLLOW ALL INSTRUCTIONS

SAVE THESE INSTRUCTIONS

INSTRUCTIONS PERTAINING TO A RISK OF FIRE, ELECTRIC SHOCK, OR INJURY TO PERSONS



WARNING: When using electrical products, basic precautions should always be followed, including the following:



DANGER: Risk of accidental injury or drowning. To reduce the risk of injury, do not permit children to use this unit unless they are closely supervised at all times.



WARNING: Risk of personal injury. To avoid injury, exercise care when entering or exiting the bath.



WARNING: Risk of electric shock. Do not permit electric appliances (such as a hair dryer, lamp, telephone, radio, or television) within 5' (1.5 m) of this bath.



WARNING: The use of alcohol, drugs, or medication can greatly increase the risk of fatal hyperthermia. Prolonged immersion in hot water may induce hyperthermia. Hyperthermia occurs when the internal temperature of the body reaches a level several degrees above the normal body temperature of 98.6°F (37°C). The symptoms of hyperthermia include an increase in the internal temperature of the body, dizziness, lethargy, drowsiness, and fainting. The effects of hyperthermia include: (a) failure to perceive heat, (b) failure to recognize the need to exit the bath, (c) unawareness of impending hazard, (d) fetal damage in pregnant women, (e) physical inability to exit the bath, and (f) unconsciousness resulting in the danger of drowning.



WARNING: Risk of fetal injury. Pregnant or possibly pregnant women should consult a physician before using the bath.



WARNING: Risk of hyperthermia or drowning. Do not use the bath immediately following strenuous exercise.



WARNING: Risk of hyperthermia or drowning. Water temperature in excess of 100°F (38°C) may cause injury. Test and adjust the water temperature before use.

Important Safety Instructions (cont.)



WARNING: Risk of personal injury. Never drop or insert any object into any opening.

Use this bath only for its intended purpose as described in this guide. Do not use attachments not recommended by Kohler Co.

The bath must be connected only to a supply circuit that is protected by a Ground-Fault Circuit-Interrupter (GFCI)*. Such a GFCI should be provided by the installer and should be tested on a routine basis. To test the GFCI, press the test button. The GFCI should interrupt power. Press the reset button. Power should be restored. If the GFCI fails to operate in this manner, the GFCI is defective. If the GFCI interrupts power to the bath without the test button being pressed, a ground current is flowing, indicating the possibility of an electric shock. Do not use this bath. Disconnect the bath and have the problem corrected by a qualified service representative before using.

Your new KOHLER bath has been listed by Underwriter's Laboratories, ensuring safety for you and your family. This bath also conforms to rigid ANSI and IAPMO standards set within the plumbing industry.

* Outside North America, this device may be known as a Residual Current Device (RCD).

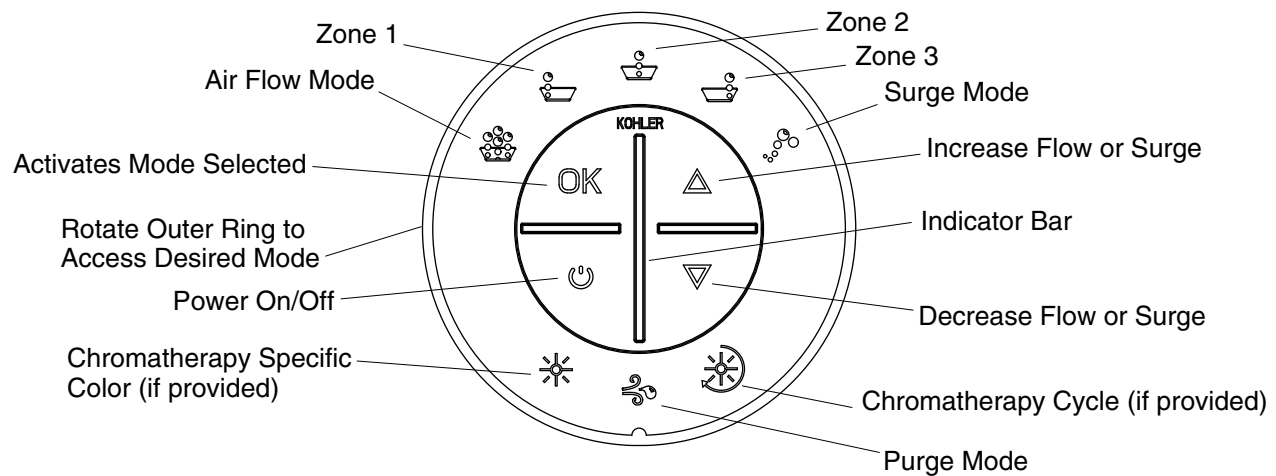

Operating Instructions

NOTE: If the unit does not function properly, please refer to the “Troubleshooting” section.

Starting the Unit

- Fill the bath to a level at least 4” (102 mm) above the top of the airjets.
- Use your hand to test the water temperature for comfort and safety.
- Carefully enter the bath basin.
- Press the On/Off icon on the user keypad.
- If desired, adjust the air flow rate using the up or down buttons.

Selecting Air Flow Modes

- Rotate the outer ring to select a desired mode.
- Press the “OK” icon to activate the mode.
- To turn off a mode, rotate the outer ring until the icon is flashing green and then press the “OK” icon again.
- The icon will then turn blue, indicating the mode is off.

Stopping the Bath

- When ready, press the On/Off icon a second time to stop the air system.
- Carefully exit the bath.
- When the bath drains below the level sensors an automatic, two-minute purge cycle occurs. The air system then operates at low speed to blow any residual water out of the air harness.

Initiating a Manual Purge Cycle (when desired)

NOTE: Follow these steps if you choose to manually purge residual water from the air system.

- After stopping the air system and draining the bath, rotate the ring on the user keypad to the “Purge” icon.
- When the “Purge” icon is flashing blue, press the “OK” icon once.
- The “Purge” icon flashes green and the manual purge mode begins. The air system operates at low speed to blow any residual water out of the air harness.
- After two minutes, the air system stops automatically.

Care and Cleaning

For best results, keep the following in mind when caring for your KOHLER bath with airjets:

- Always test your cleaning solution on an inconspicuous area before applying to the entire surface.
- Wipe surfaces clean and rinse completely with water immediately after applying cleaner. Rinse and dry any overspray that lands on nearby surfaces.
- Do not allow cleaners to soak on surfaces.
- Use a soft, dampened sponge or cloth. Never use an abrasive material such as a brush or scouring pad to clean surfaces.
- The ideal cleaning technique is to rinse thoroughly and blot dry any water from the surface after each use.
- Use a soft nylon brush on slip-resistant surfaces. Be sure to use a water-soluble cleaner (dissolves 100% in water).
- **Do not use powdered cleaners unless the cleaner is fully dissolved in water.** Solid substances can block the airjets.
- **Do not use full strength bleach or ammonia cleaning solutions.** Chemically active cleaning solutions can damage the surface.
- **Do not use abrasive cleansers or solvents on airjet surfaces.** Abrasive cleaners and solvents can damage the airjet surface.

Maintaining the Airjets

- If cleaning the airjets is necessary due to hard water deposits, wet a soft, non-abrasive cloth with white vinegar and wipe the plugged airjet holes. Immediately rinse the area with clean water to avoid long-term exposure of the vinegar to the airjet surface.
- Fill the bath with water to the top row of airjets. Drain the bath and press the purge button.

Cleaning Your User Keypad and Remote Control

- Use a soft cloth to wipe the keypad and remote control after each use. If the surface becomes dirty, use a non-abrasive soap and warm water to clean.

For detailed cleaning information and products to consider, visit www.kohler.com/clean. To order Care & Cleaning information, call 1-800-456-4537.

Warranty

Kohler Co. warrants the cast iron components of products manufactured after February 10, 2000, to be free of defects in material and workmanship during normal residential use for as long as the original consumer purchaser owns his or her home. Gloss reduction, scratching, staining and alkaline etching of the finish over time due to use, cleaning practices or water or atmospheric conditions, are not manufacturing defects but are indicative of normal wear and tear. This warranty applies only for KOHLER Cast Iron products installed in the United States of America, Canada or Mexico (North America).

If a defect is found in normal residential use, Kohler Co. will, at its election, repair, replace or make appropriate adjustment. Damage caused by accident, misuse, or abuse is not covered by this warranty. Improper care and cleaning will void the warranty. Proof of purchase (original sales receipt) must be provided to Kohler Co. with all warranty claims. Kohler Co. is not responsible for labor charges, installation, or other incidental or consequential costs. In no event shall the liability of Kohler Co. exceed the purchase price of the product.

If the cast iron product is used commercially or is installed outside of North America, Kohler Co. warrants the cast iron product to be free from defects in material and workmanship for one (1) year from the date the product is installed, with all other terms of this warranty applying except duration. All other components other than the enameled cast iron carry Kohler Co.'s one-year limited warranty unless otherwise specified.

If you believe that you have a warranty claim, contact Kohler Co., either through your Dealer, Plumbing Contractor, Home Center or E-tailer, or by writing: Kohler Co., Attn.: Customer Care Center, 444 Highland Drive, Kohler, WI 53044, USA. Please be sure to provide all pertinent information regarding your claim, including a complete description of the problem, the product, model number, color, finish, the date the product was purchased and from whom the product was purchased. Also include your original invoice. For other information, or to obtain the name and address of the service and repair facility nearest you call

Warranty (cont.)

1-800-4-KOHLER (1-800-456-4537) from within the USA and Canada, and 001-800-456-4537 from within Mexico, or visit www.kohler.com within the USA, www.ca.kohler.com from within Canada, or www.mx.kohler.com in Mexico.

KOHLER CO. AND/OR SELLER ARE PROVIDING THIS WARRANTY IN LIEU OF ALL OTHER WARRANTIES, EXPRESSED OR IMPLIED, INCLUDING BUT NOT LIMITED TO THE IMPLIED WARRANTIES OF MERCHANTABILITY AND FITNESS FOR A PARTICULAR PURPOSE. KOHLER CO. AND/OR SELLER DISCLAIMS ANY LIABILITY FOR SPECIAL, INCIDENTAL OR CONSEQUENTIAL DAMAGES.

Some states/provinces do not allow limitations on how long an implied warranty lasts, or the exclusion or limitation of special, incidental or consequential damages, so these limitations and exclusions may not apply to you. This warranty gives the consumer specific legal rights. You may also have other rights, which vary, from state/province to state/province. This warranty is to the original consumer purchaser only, and excludes product damage due to installation error, product abuse, or product misuse, whether performed by a contractor, service company or the consumer.

This is Kohler Co.'s exclusive written warranty.

Warranty

ONE-YEAR LIMITED WARRANTY

KOHLER plumbing products are warranted to be free of defects in material and workmanship for one year from date of installation.

Kohler Co. will, at its election, repair, replace or make appropriate adjustment where Kohler Co. inspection discloses any such defects occurring in normal usage within one (1) year after installation. Kohler Co. is not responsible for removal or installation costs. **Use of in-tank toilet cleaners will void the warranty.**

To obtain warranty service contact Kohler Co. either through your Dealer, Plumbing Contractor, Home Center or E-tailer, or by writing Kohler Co., Attn.: Customer Care Center, 444 Highland Drive, Kohler, WI 53044, USA, or by calling 1-800-4-KOHLER (1-800-456-4537) from within the USA and Canada, and 001-800-456-4537 from within Mexico, or visit www.kohler.com within the USA, www.ca.kohler.com from within Canada, or www.mx.kohler.com in Mexico.

IMPLIED WARRANTIES INCLUDING THAT OF MERCHANTABILITY AND FITNESS FOR A PARTICULAR PURPOSE ARE EXPRESSLY LIMITED IN DURATION TO THE DURATION OF THIS WARRANTY. KOHLER CO. AND/OR SELLER DISCLAIM ANY LIABILITY FOR SPECIAL, INCIDENTAL OR CONSEQUENTIAL DAMAGES. Some states/provinces do not allow limitations on how long an implied warranty lasts, or the exclusion or limitation of special, incidental or consequential damages, so these limitations and exclusions may not apply to you. This warranty gives you specific legal rights. You may also have other rights which vary from state/province to state/province.

This is Kohler Co.'s exclusive written warranty.

Warranty

For Mexico

KOHLER CO.

It is recommended that at the time of purchase, you verify that all accessories and components are complete in this package.

This Kohler product is warranted to be free of defects in material and workmanship for one (1) year from the date of purchase as shown on the invoice or receipt.

1. Kohler Co. will only service its commercialized products through its authorized distributors.
2. To obtain warranty service, please present the invoice and corresponding warranty.
3. Through its authorized distributors, Kohler Co. promises to repair the defective product or provide a new

Warranty (cont.)

replacement or an equivalent model (in those cases that the model has been discontinued) when the product is beyond repair, without any charge to the consumer.

4. The time of repair will not exceed six (6) weeks commencing on the date the product is received.
5. It is recommended that the consumer save the invoice or receipt as additional protection, as it may substitute the warranty in the case that there is a discrepancy in the validity of the warranty.

EXCEPTIONS AND RESTRICTIONS

The Warranty will not be valid in the following cases:

1. When the product is not operated in accordance with the instructions concerning use and operation set forth in the owner's manual or installation instructions, and when the recommendations and warnings included are not observed.
2. When the product has been modified or dismantled partially or totally; or has been used in a negligent fashion and as a consequence has suffered damages attributable to the consumer, individual, or hardware not authorized by Kohler Co.
3. This warranty does not cover the damages as a result of disaster such as fire or acts of God, including flooding, earthquake, or electric storms, etc. To obtain a list of distributors in your area where you can exercise your rights under this warranty, please call 001-800-456-4537.

KOHLER CO., KOHLER, WI 53044 U.S.A.

IMPORTER:

INTERNACIONAL DE CERÁMICA, S.A.B. DE C.V.

AV. CARLOS PACHECO NO. 7200

CHIHUAHUA, CHIH., MEXICO C.P. 31060

TEL: 52 (14) 29-11-11

Troubleshooting

NOTICE: This section is for general aid only. A Kohler Co. Authorized Service Representative or qualified electrician should correct any electrical problems. For warranty service, call 1-800-4KOHLER from within the USA and Canada, or 001-800-456-4537 from within Mexico.

NOTE: The product model number is printed on a label on the blower side of the bath.

NOTE: For service parts information, visit your product page at www.kohler.com/serviceparts.

Troubleshooting the Bath System

Symptoms	Probable Causes	Recommended Action
1. User keypad does not illuminate when Power icon is pressed or the outer ring is rotated.	A. No power to control.	A. Check wiring and connect power.
	B. Ground-Fault Circuit-Interrupter (GFCI) or Residual Current Device (RCD) tripped.	B. Reset GFCI or RCD. If it trips again, refer to "Ground-Fault Circuit-Interrupter (GFCI) or Residual Current Device (RCD) trips when bath is turned on."
	C. Wiring harness from user keypad to control is loose, disconnected or damaged.	C. Check wiring for proper connections. Replace the wiring harness if necessary.
	D. User keypad does not work.	D. Replace the user keypad.
	E. Control does not work.	E. Replace the control.

Troubleshooting (cont.)		
Symptoms	Probable Causes	Recommended Action
2. Ground-Fault Circuit-Interrupter (GFCI) or Residual Current Device (RCD) trips when bath is turned on.	A. Electrical harness is wet or damaged.	A. Check for wet connections. Dry the connections and repair the leak. Check for insulation or connector damage. Replace the harness if damaged.
	B. Electrical wiring to the bath junction box is wet or damaged; or the power amperage is inadequate.	B. Have a qualified electrician diagnose and correct the problem in accordance with applicable building and electrical codes; or increase the power amperage to 20 A.
	C. Electrical wiring to the bath power cord is wet or damaged.	C. Have a qualified electrician diagnose and correct the problem in accordance with applicable building and electrical codes.
	D. Blower motor is shorted internally.	D. Replace the blower motor.
	E. Control is shorted internally.	E. Replace the control.
3. User keypad is illuminated, but does not respond to icons or outer ring.	A. Control program is locked.	A. Reset GFCI or RCD.
	B. P5 plug assembly harness from user keypad to control is loose, disconnected, or damaged.	B. Check wiring for proper connections. Replace the wiring harness if necessary.
	C. User keypad does not work.	C. Replace the user keypad.
	D. Control does not work.	D. Replace the control.
4. Blower motor will not start.	A. Power cord from blower motor to control is loose, disconnected, or damaged.	A. Check wiring for proper connections.
	B. Blower motor does not work.	B. Replace the blower motor.
	C. Control does not work.	C. Replace the control.
5. Blower motor stops running and will not immediately restart. Keypad is illuminated.	A. Blower motor overheated and protection device activated.	A. Check for blockage at air inlet. Remove blockage and allow motor to cool. Refer to "User keypad is illuminated, but does not respond to icons or outer ring. Blower motor will not start."
6. Blower motor starts, some but not all airjets are bubbling.	A. Blower motor speed is too low.	A. Increase speed set point to blower motor.
	B. Blower air inlet is blocked.	B. Clear blower air inlet.
	C. Blower motor does not work.	C. Replace the blower motor.
	D. Blower motor discharge is blocked.	D. Clear blockage.
	E. Check valve does not work.	E. Replace the check valve.
	F. Airjets are clogged.	F. Use a small between-the-teeth dental brush and white vinegar. Dip the brush in the vinegar, brush the hole, rinse the brush in clean water, and then use the wet rinsed brush to rinse the hole.
	G. Some zones are closed.	G. Operate all zones.

Troubleshooting (cont.)		
Symptoms	Probable Causes	Recommended Action
7. Blower motor runs but no air bubbles are formed.	A. Blower air inlet is blocked.	A. Clean blower air inlet.
	B. Airjets are clogged.	B. Use a small between-the-teeth dental brush and white vinegar. Dip the brush in the vinegar, brush the hole, rinse the brush in clean water, and then use the wet rinsed brush to rinse the hole.
	C. Check valve does not work.	C. Replace the check valve.
	D. Blower motor does not work.	D. Replace the blower motor.
	E. Control does not work.	E. Replace the control.
8. Blower motor operates, air bubbles are formed, zone controls work, but variable speed feature does not work.	A. Blower air inlet is blocked.	A. Clear blower air inlet.
	B. Loose, disconnected, or damaged wiring harness.	B. Check wiring for proper connections. Replace the wiring harness if necessary.
	C. User keypad does not work.	C. Replace the user keypad.
	D. Blower motor does not work.	D. Replace the blower motor.
	E. Control does not work.	E. Replace the control.
9. Blower motor won't turn off when the Power icon on user keypad is pressed.	A. User keypad does not work.	A. Replace the user keypad.
	B. Loose, disconnected, or damaged wiring harness.	B. Check wiring for proper connections. Replace the wiring harness if necessary.
	C. Control does not work.	C. Replace the control.
10. A zone does not produce air bubbles but another zone operates normally.	A. Zone is not selected.	A. Select the zone according to the instructions in the "Operating Instructions" section.
	B. Butterfly valve does not work.	B. Replace the butterfly valve.
	C. Loose, disconnected, or damaged wiring harness.	C. Check wiring for proper connections. Replace the wiring harness if necessary.
	D. User keypad does not work.	D. Replace the user keypad.
	E. Control does not work.	E. Replace the control.
11. Surge mode does not work.	A. User keypad does not work.	A. Replace the user keypad.
	B. Control does not work.	B. Replace the control.
12. Water spillage or damage observed under the bath.	A. Drain or overflow leaking.	A. Repair or replace the drain assembly according to the manufacturer's instructions.
	B. Wall, deck, and/or shower door is improperly sealed.	B. Apply silicone sealant at the seams between the bath and the wall, deck, or door.
	C. Cracked piping or air channels.	C. Refer to the manufacturer.
13. Bath does not purge automatically.	A. Level sensor wires are disconnected.	A. Connect the level sensor wires.
Chromatherapy (if equipped)		
Symptoms	Probable Causes	Recommended Action
14. Chromatherapy lights do not work.	A. Loose, disconnected or damaged wiring/connections.	A. Check wiring for proper connections. Replace wiring if necessary.
	B. Control does not work.	B. Replace control.
15. Chromatherapy does not cycle.	A. Chromatherapy harness assembly does not work.	A. Replace the chromatherapy harness assembly.