

Installation and Care Guide

120 V Bath Whirlpool
Custom Pump Location

Save These Instructions
Conserver ces instructions
Guarde estas instrucciones

Retain serial number for reference.

Numéro de série du produit:

Número de serie del producto: _____

Français, page "Français-1"

Español, página "Español-1"

THE BOLD LOOK
OF **KOHLER**®

1193347-2-A

Installation Instructions



WARNING: When using electrical products, basic precautions should always be followed, including the following:



DANGER: Risk of electric shock. Connect only to a circuit protected by a Ground-Fault Circuit-Interrupter (GFCI)*.

Building materials and wiring should be routed away from the pump body and other heat-producing components of the unit.

Install to permit access for servicing.

A pressure wire connector marked "Earth/Ground" is provided within the wiring compartment. To reduce the risk of electric shock, connect this connector to the grounding terminal of your electric service or supply panel with copper wire equivalent in size to the circuit conductor supplying this equipment.

Pressure wire connectors are provided on the exterior of the junction box or control within this unit to permit connection of a bonding conductor between this unit and all other exposed metal in the vicinity, as needed to comply with local requirements.

Grounding is required. The unit should be installed by a qualified service representative, and grounded.



WARNING: Risk of injury or property damage. Please read all instructions thoroughly before beginning installation, including the following requirements.



WARNING: Risk of electric shock. A qualified electrician should make all electrical connections.



WARNING: Risk of electric shock. Disconnect power before servicing.

NOTICE: Follow all local plumbing and electrical codes. In Canada, install this unit in accordance with the Canadian Electrical Code, Part 1.

*Outside North America, this device may be known as a Residual Current Device (RCD).

Product Information

Electrical Requirements

The installation must have a Class A Ground-Fault Circuit-Interrupter (GFCI) or Residual Current Device (RCD). The GFCI or RCD protect against line-to-ground shock hazard. **Use a 120 V, 15 A, 60 Hz dedicated service for the whirlpool.**

"H" models require a separate 120 V, 15 A, 60 Hz dedicated service for the heater.

If the pump supply cord is damaged, it must be replaced by the manufacturer, its service agent or similarly qualified persons in order to avoid a hazard. The heater supply cord cannot be replaced. If the heater supply cord is damaged the heater must be replaced.

Product Notices



WARNING: Unauthorized modification may cause unsafe operation and poor performance of the whirlpool. Do not relocate the whirlpool pump, or make other modifications to the whirlpool system, as this could adversely affect the performance and safe operation of the whirlpool. Kohler Co. shall not be liable under its warranty or otherwise for personal injury or damage caused by any such unauthorized modification.

Product Information (cont.)

Features

Factory installed components include a pump with power supply cord and an air switch transmitter.

"H" models are also supplied with a factory-assembled heater.

The whirlpool pump and piping are factory-assembled.

Tools and Materials

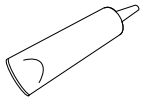

Silicone Sealant



Tape Measure

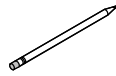

Pencil



Safety Glasses

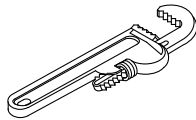

Pipe Wrench

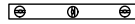

Level

Plus:

- Conventional woodworking tools and materials
- Drop Cloth
- Construction adhesive (optional)
- Cement or mortar (optional)
- 2x4s or 2x6s
- Screws or Lag Bolts

Alcove

Position the rough plumbing.

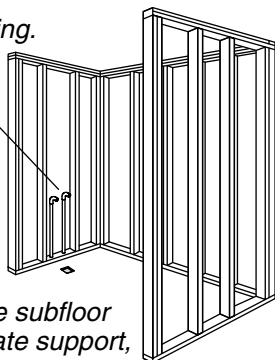

Construct 2x4 stud framing according to the product dimensions.

Verify that the subfloor offers adequate support, and is flat and level.

Drop-In

Position the rough plumbing.

Construct according to the product dimensions.

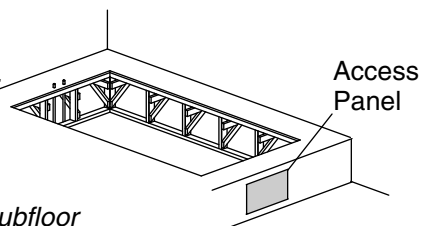

Verify that the subfloor offers adequate support, and is flat and level.

1. Prepare the Site

NOTICE: Measure your actual product for site preparation. Note the **model number** located on the whirlpool pump, then visit the product page at www.kohler.com for additional information.

NOTICE: Provide generous, unrestricted access to the pump. You must provide access for servicing the pump. The access must be located immediately next to the pump.

NOTICE: Do not lift the whirlpool by the piping or pump, or use the piping or pump for structural support of the whirlpool. To avoid damage to the whirlpool, lift at the sides of the whirlpool.

NOTICE: Do not support the load weight of the whirlpool by the rim.

NOTE: Drop-in, alcove, or corner installation is possible, depending on the product chosen.

- Carefully unpack and inspect the new whirlpool for damage before installation. If there is damage do not install the whirlpool; contact your dealer.
- Make sure the flooring offers adequate support for your whirlpool, and verify that the subfloor is flat and level.
- Construct 2x4 stud framing.
- Install an access panel for future pump servicing. The access panel must be at least 20" (508 mm) wide by 15" (381 mm) high.
- Install the rough plumbing.
- Install the drain to the whirlpool according to the drain manufacturer's instructions.
- Protect the whirlpool surface by positioning a clean drop cloth in the basin bottom.

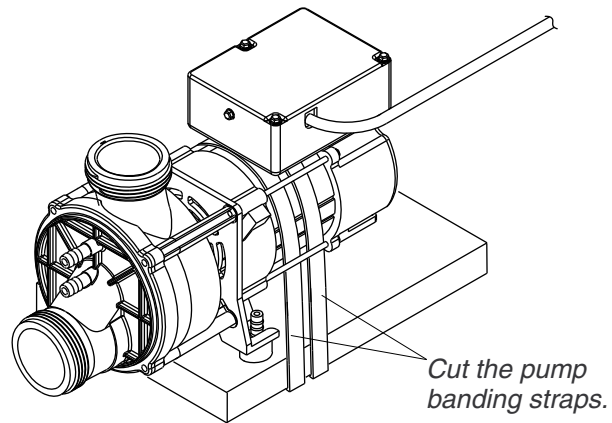

2. Disconnect the Pump

NOTE: Do not cut the whirlpool harness (piping) for this custom installation.

- Disconnect the pump and heater (if included) from the shipping location by cutting the two banding straps with a tin snips.
- Move the pump and heater aside.
- Relocate the pump and heater next to the customized inlet/outlet connections of the whirlpool harness. The pump may protrude beyond the rim of the bath.

Option 1

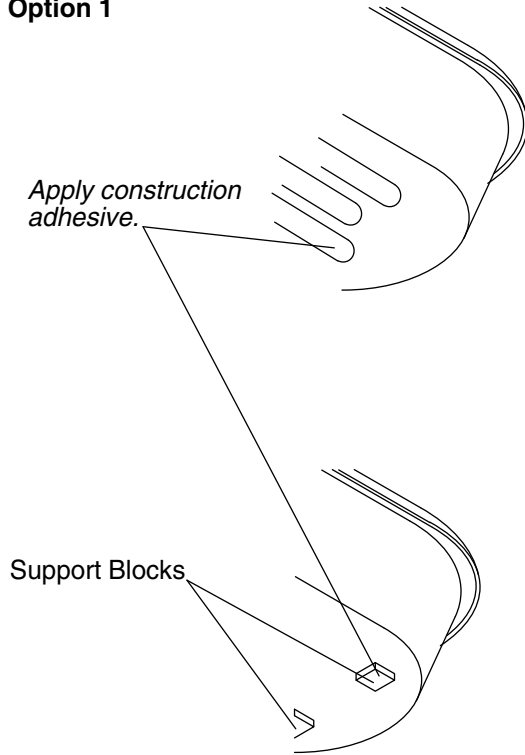

Option 2

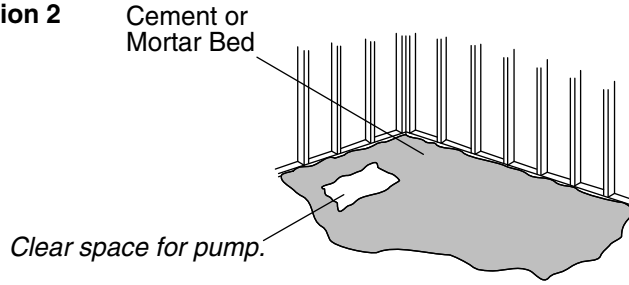

Three Wall Alcove or Corner Installations

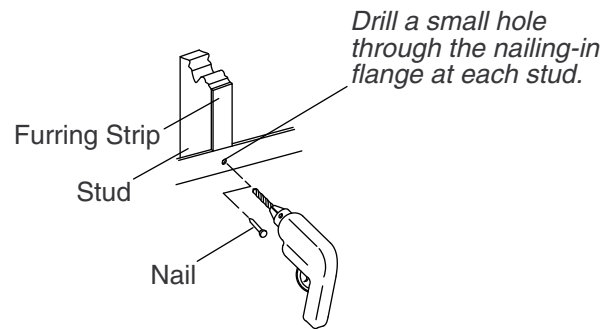

3. Install the Whirlpool

NOTICE: Do not lift the whirlpool by the piping or pump, or use the piping or pump for structural support of the whirlpool. To avoid damage to the whirlpool, lift at the sides of the whirlpool.

- If the subfloor is not level, shim the whirlpool support blocks or molded supports as necessary.

Option 1: Install Using Construction Adhesive

NOTE: Some models come with support blocks; some models have molded supports.

- Apply a generous amount of high-quality construction adhesive to the bottom of the support blocks or molded supports. With help, carefully lift the whirlpool into position.

Option 2: Using a Cement or Mortar Bed

NOTE: Do not use gypsum cement or drywall compound for this application, as they will not provide an acceptable, durable bond.

- Set the basin area in 1" (25 mm) to 2" (51 mm) of mortar cement.

NOTE: The pump support (when the pump banding straps are cut) must rest directly on the subfloor. The pump control should not be in contact with mortar.

Secure the Nailing-in Flanges (Alcove Units)

- Drill a small pilot hole through the nailing-in flange at each stud. Add shims as needed.
- Use large-head galvanized nails to secure the nailing-in flange to the studs.
- Nail 1/4" (6 mm) thick furring strips to the studs.

Install the Plumbing

Install the Whirlpool (cont.)

- Insert the drain tailpiece into the trap. Secure the drain tailpiece to the trap.
- Install the faucet valve.
- Check the drain connections for leakage.
- If required, install the grab bars according to the instructions.

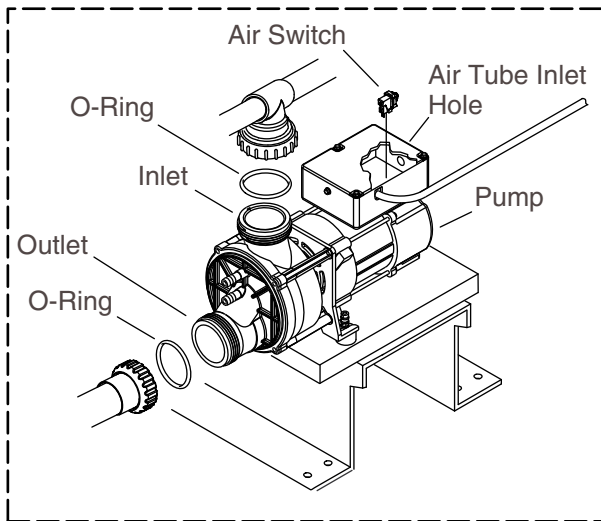

When installing the pump, make sure to remove the plugs from the inlet and outlet piping.

Provide access to the installed pump for servicing.

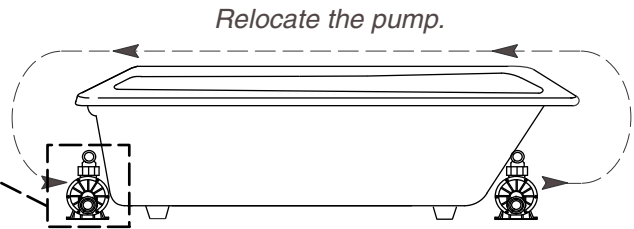

4. Relocate and Connect the Pump

- Remove all protective packaging from around the whirlpool harness. Cut only those cable ties supporting the harness attachment nuts.
- Remove the plugs from the pump inlet and outlet. Install the O-rings into the grooves on the inlet and outlet connectors.
- Set the pump on the support bracket.
- Thread the plastic inlet and outlet nuts onto the pump until the O-rings make initial contact.
- Tighten each nut a quarter turn after initial contact. **Do not overtighten these nuts.**

NOTE: Do not raise the pump higher than it was before you cut the straps. If the pump is raised too high, it will not prime properly. Make sure the rubber isolation feet are in place.

- Make sure the whirlpool harness inlet piping (suction line) is pitched downward from the pump toward the suction fitting. This is important so the pump will drain water properly. Shim the pump if necessary to promote proper drainage.
- Secure the pump support bracket with four screws or lag bolts (not provided).
- Connect the air tubing to the air switch on the pump.

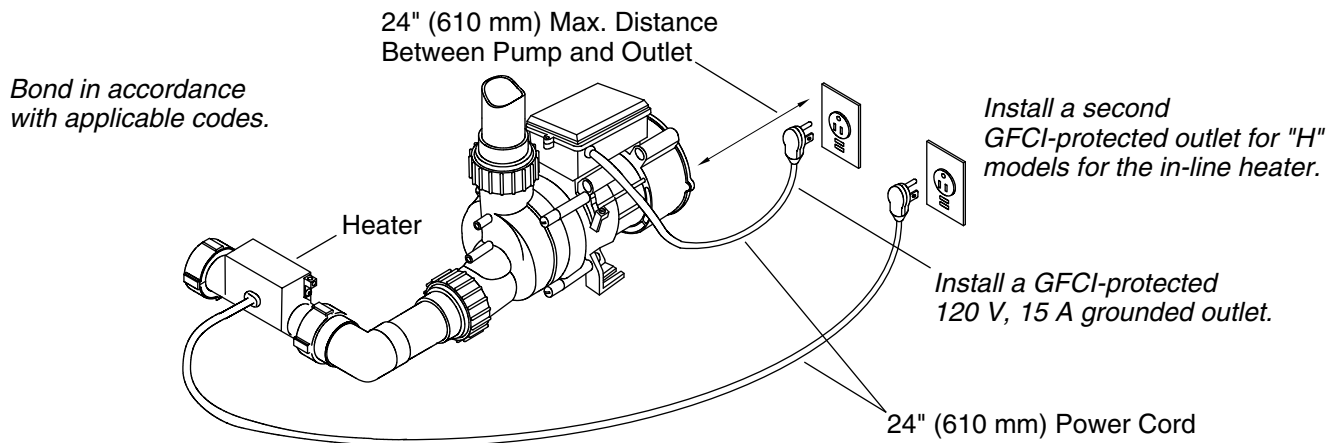

5. Make the Electrical Connections



WARNING: Risk of electric shock. Make sure the power has been disconnected before performing the following procedures.



WARNING: Risk of electric shock. Connect the pump and heater (if included) to properly grounded, grounding-type receptacles protected by Ground-Fault Circuit-Interrupters (GFCI's) or Residual Current Devices (RCD's). Do not remove the grounding pins from the plugs. Do not use grounding adapters.

NOTE: A label identifying the model number and electrical rating of the whirlpool is located near the whirlpool pump.

NOTICE: The pump and heater (if included) are each equipped with a cord and plug. All wiring for the heater has been completed at the factory. A qualified electrician must install a GFCI- or RCD-protected, 120 V, 15 A, grounded outlet for the pump, and another for the heater. No other load should be on these circuits.

- Install an electrical outlet behind the whirlpool, and within reach of the 24" (610 mm) pump power cord.
- Plug the pump plug into this outlet.

NOTE: Make sure the air actuator tubing is securely attached to the pump, and is not kinked or damaged.

- For units with heaters, install a second outlet behind the whirlpool and within reach of the 24" (610 mm) heater power cord.
- Plug the heater plug into this outlet.

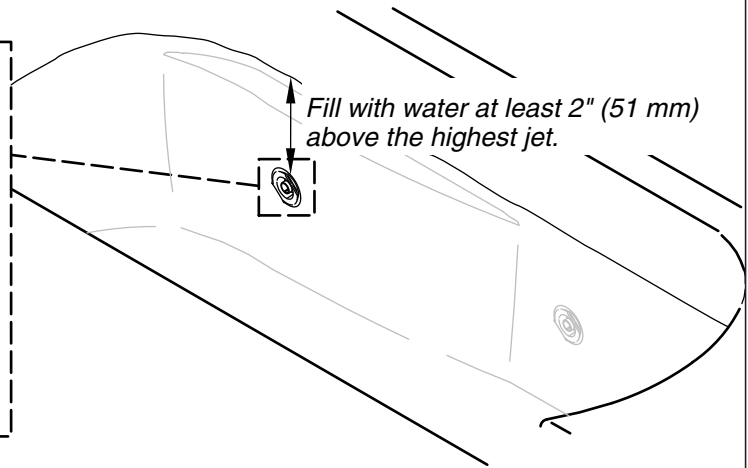
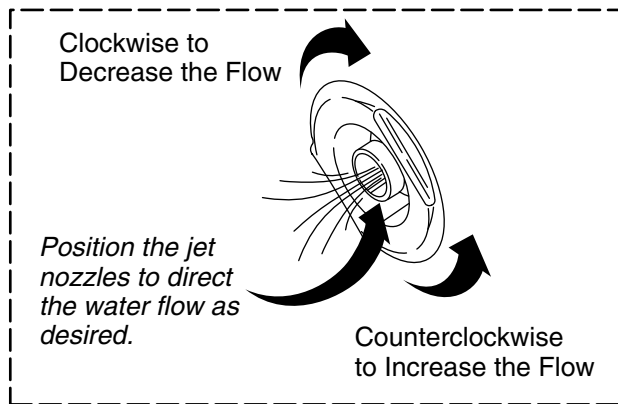

6. Complete the Installation

Test Run the Whirlpool

- Fill the whirlpool to a level at least 2" (51 mm) above the top of the highest jet.
- Operate the whirlpool for 5 minutes and check all whirlpool piping connections for leaks. Check for leakage along the front, sides, and back of the whirlpool.
- For additional information on whirlpool operation, see the "Operating Instructions" section.

Finish the Installation

- Install water-resistant wallboard and all finished wall, deck, and floor materials.
- Apply silicone sealant to seal all areas where the whirlpool and finished wall or deck meet.
- Install the faucet trim.

Clean-up After Installation

- When cleaning up after installation, **do not use abrasive cleansers**, as they may scratch and dull the whirlpool surface. Use warm water and a liquid detergent to clean the surface of the whirlpool.
- Remove stubborn stains or paint with turpentine or paint thinner. **Do not allow cleaners containing petroleum distillates to remain in contact with any whirlpool surface for long periods of time.** Remove plaster by carefully scraping with a wood edge. Do not use metal scrapers, wire brushes, or other metal tools. Use a powder-type detergent on a damp cloth to provide mild abrasive action to any residual plaster.

Important Safety Instructions

INSTRUCTIONS PERTAINING TO A RISK OF FIRE, ELECTRICAL SHOCK, OR INJURY TO PERSONS

READ AND FOLLOW ALL INSTRUCTIONS

SAVE THESE INSTRUCTIONS

INSTRUCTIONS PERTAINING TO A RISK OF FIRE, ELECTRIC SHOCK, OR INJURY TO PERSONS



WARNING: When using electrical products, basic precautions should always be followed, including the following:

Important Safety Instructions (cont.)



DANGER: Risk of accidental injury or drowning. To reduce the risk of injury, do not permit children to use this unit unless they are closely supervised at all times.



WARNING: Risk of personal injury. To avoid injury, exercise care when entering or exiting the whirlpool.



WARNING: Risk of electric shock. Do not permit electric appliances (such as a hair dryer, lamp, telephone, radio, or television) within 5' (1.5 m) of this whirlpool.



WARNING: The use of alcohol, drugs, or medication can greatly increase the risk of fatal hyperthermia. Prolonged immersion in hot water may induce hyperthermia. Hyperthermia occurs when the internal temperature of the body reaches a level several degrees above the normal body temperature of 98.6°F (37°C). The symptoms of hyperthermia include an increase in the internal temperature of the body, dizziness, lethargy, drowsiness, and fainting. The effects of hyperthermia include: (a) failure to perceive heat, (b) failure to recognize the need to exit the whirlpool, (c) unawareness of impending hazard, (d) fetal damage in pregnant women, (e) physical inability to exit the whirlpool, and (f) unconsciousness resulting in the danger of drowning.



WARNING: Risk of hyperthermia. People using medications and/or having an adverse medical history should consult a physician before using a whirlpool equipped with a heater.



WARNING: Risk of fetal injury. Pregnant or possibly pregnant women should consult a physician before using the whirlpool.



WARNING: Risk of hyperthermia or drowning. Do not use the whirlpool immediately following strenuous exercise.



WARNING: Risk of hyperthermia or drowning. Water temperature in excess of 100°F (38°C) may cause injury. Test and adjust the water temperature before use.



WARNING: Risk of personal injury or drowning. Do not operate this unit without the guard (cover) over the suction fitting.



WARNING: Risk of personal injury. Never drop or insert any object into any opening.

Use this whirlpool only for its intended purpose as described in this guide. Do not use attachments not recommended by Kohler Co.

The whirlpool must be connected only to a supply circuit that is protected by a Ground-Fault Circuit-Interrupter (GFCI)*. Such a GFCI should be provided by the installer and should be tested on a routine basis. To test the GFCI, press the test button. The GFCI should interrupt power. Press the reset button. Power should be restored. If the GFCI fails to operate in this manner, the GFCI is defective. If the GFCI interrupts power to the whirlpool without the test button being pressed, a ground current is flowing, indicating the possibility of an electric shock. Do not use this whirlpool. Disconnect the whirlpool and have the problem corrected by a qualified service representative before using.

Your new KOHLER whirlpool has been listed by Underwriter's Laboratories, ensuring safety for you and your family. This whirlpool also conforms to rigid ANSI and IAPMO standards set within the plumbing industry.

* Outside North America, this device may be known as a Residual Current Device (RCD).

Operating Instructions

NOTE: The water temperature in the whirlpool should never exceed 104°F (40°C).

- Close the drain, then fill the whirlpool at least 2" (51 mm) above the top of the highest jet.

Operating Instructions (cont.)

- Use your hand to test the water temperature for comfort and safety, then carefully enter the whirlpool.
- Press the air switch to turn on the pump.

NOTE: If equipped, the heater will automatically turn on.

- Adjust the jets for optimum air/water mixture. Turn the jet trim rings clockwise to reduce the flow or counterclockwise to increase the flow. Position the jet nozzles to direct the water flow as desired.
- Press the air switch a second time to turn off the pump.
- Carefully exit the whirlpool, then open the drain and empty the water.

NOTE: If the whirlpool does not function properly, refer to the "Troubleshooting Procedures" section.

Care and Cleaning

For best results, keep the following in mind when caring for your KOHLER product:

- Always test your cleaning solution on an inconspicuous area before applying to the entire surface.
- Wipe surfaces clean and rinse completely with water immediately after applying cleaner. Rinse and dry any overspray that lands on nearby surfaces.
- Do not allow cleaners to soak on surfaces.
- Use a soft, dampened sponge or cloth. Never use an abrasive material such as a brush or scouring pad to clean surfaces.

For detailed cleaning information and products to consider, visit www.kohler.com/clean. To order Care & Cleaning information, call 1-800-456-4537.

Flush the System

NOTE: Flush your whirlpool system twice a month or more, depending upon usage.

- Turn the jet trim rings fully clockwise to reduce air induction.
- Fill the whirlpool with hot water to a level at least 2" (51 mm) above the highest jet.
- Add 2 teaspoons (10 ml) of a low-foaming, powder automatic dishwasher detergent and 20 ounces (590 ml) of household bleach (5% - 6% sodium hypochlorite) to the water.
- Run the whirlpool for 5 to 10 minutes. Turn off the whirlpool and drain.
- If desired, rinse the bath surfaces with water.
- Rinse the surfaces of the jets, faucet, grab bars, and drain, and wipe them dry with a soft cloth.

Warranty

ONE-YEAR LIMITED WARRANTY

KOHLER plumbing products are warranted to be free of defects in material and workmanship for one year from date of installation.

Kohler Co. will, at its election, repair, replace or make appropriate adjustment where Kohler Co. inspection discloses any such defects occurring in normal usage within one (1) year after installation. Kohler Co. is not responsible for removal or installation costs. **Use of in-tank toilet cleaners will void the warranty.**

To obtain warranty service contact Kohler Co. either through your Dealer, Plumbing Contractor, Home Center or E-tailer, or by writing Kohler Co., Attn.: Customer Care Center, 444 Highland Drive, Kohler, WI 53044, USA, or by calling 1-800-4-KOHLER (1-800-456-4537) from within the USA and Canada, and 001-800-456-4537 from within Mexico, or visit www.kohler.com within the USA, www.ca.kohler.com from within Canada, or www.mx.kohler.com in Mexico.

IMPLIED WARRANTIES INCLUDING THAT OF MERCHANTABILITY AND FITNESS FOR A PARTICULAR PURPOSE ARE EXPRESSLY LIMITED IN DURATION TO THE DURATION OF THIS WARRANTY. KOHLER CO. AND/OR SELLER DISCLAIM ANY LIABILITY FOR SPECIAL,

Warranty (cont.)

INCIDENTAL OR CONSEQUENTIAL DAMAGES. Some states/provinces do not allow limitations on how long an implied warranty lasts, or the exclusion or limitation of special, incidental or consequential damages, so these limitations and exclusions may not apply to you. This warranty gives you specific legal rights. You may also have other rights which vary from state/province to state/province.

This is Kohler Co.'s exclusive written warranty.

Warranty

For Mexico

KOHLER CO.

It is recommended that at the time of purchase, you verify that all accessories and components are complete in this package.

This Kohler product is warranted to be free of defects in material and workmanship for one (1) year from the date of purchase as shown on the invoice or receipt.

1. Kohler Co. will only service its commercialized products through its authorized distributors.
2. To obtain warranty service, please present the invoice and corresponding warranty.
3. Through its authorized distributors, Kohler Co. promises to repair the defective product or provide a new replacement or an equivalent model (in those cases that the model has been discontinued) when the product is beyond repair, without any charge to the consumer.
4. The time of repair will not exceed six (6) weeks commencing on the date the product is received.
5. It is recommended that the consumer save the invoice or receipt as additional protection, as it may substitute the warranty in the case that there is a discrepancy in the validity of the warranty.

EXCEPTIONS AND RESTRICTIONS

The Warranty will not be valid in the following cases:

1. When the product is not operated in accordance with the instructions concerning use and operation set forth in the owner's manual or installation instructions, and when the recommendations and warnings included are not observed.
2. When the product has been modified or dismantled partially or totally; or has been used in a negligent fashion and as a consequence has suffered damages attributable to the consumer, individual, or hardware not authorized by Kohler Co.
3. This warranty does not cover the damages as a result of disaster such as fire or acts of God, including flooding, earthquake, or electric storms, etc. To obtain a list of distributors in your area where you can exercise your rights under this warranty, please call 001-800-456-4537.

KOHLER CO., KOHLER, WI 53044 U.S.A.

IMPORTER:

INTERNACIONAL DE CERÁMICA, S.A.B. DE C.V.

AV. CARLOS PACHECO NO. 7200

CHIHUAHUA, CHIH., MEXICO C.P. 31060

TEL: 52 (14) 29-11-11

Remove the Jets

Insert the tool hook as shown and pull the jet out of the housing. The jet should be facing up when this is done.

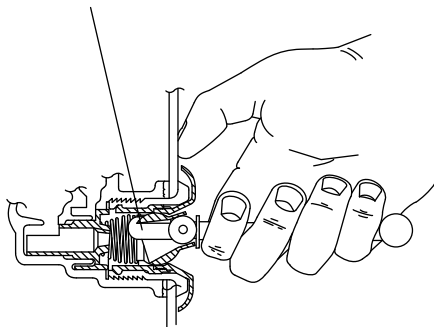

Reinstall the Jets

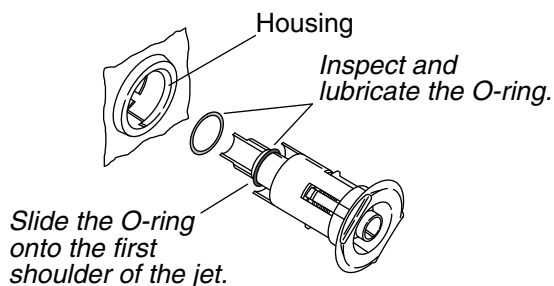

Insert the jet into the housing, and lightly push and rotate until it snaps in position.

Troubleshooting Procedures

NOTICE: This section is for general aid only. A Kohler Co. Authorized Service Representative or qualified electrician should correct any electrical problems. For warranty service, call 1-800-4KOHLER from within the USA and Canada, or 001-800-456-4537 from within Mexico.

For service parts information, visit your product page at www.kohler.com.

Remove the Jets

NOTE: A special tool is provided with the replacement jets that will allow you to remove the jets from the whirlpool. This tool is also supplied with each trim kit.

- Position the jet ball nozzle so it is pointing upward.
- Insert the removal tool, hooked end up, into the opening of the jet and hook the inside top of the nozzle.
- Grasp the tool firmly and place your thumb against the whirlpool wall. Pull steadily on the tool until the jet assembly pulls free of the hole. Be careful not to lose the O-ring.

Reinstall the Jets

NOTE: To allow easy rotation and proper operation of the jet, the O-ring must be: (1) correctly positioned, (2) lubricated, and (3) in good condition.

- Install the O-ring onto the **first shoulder** of the jet.
- Using the silicone lube packet (provided), lubricate the O-ring to prevent noisy operation of the jet.
- Carefully insert the jet into the housing, then lightly push and rotate the jet until it snaps into position. **Do not force the jet.**
- Verify the jet is installed correctly. The jet should turn smoothly both clockwise and counterclockwise. Remove and reinstall, if necessary.

Troubleshooting Procedures (cont.)

Symptoms	Probable Causes	Recommended Action
1. Whirlpool does not start or stop.	<p>A. No power to motor.</p> <p>B. Air hose is loose or disconnected.</p> <p>C. Air hose is pinched or kinked.</p> <p>D. Push button assembly is damaged.</p> <p>E. Push button has grease in the bleed area.</p> <p>F. Air hose is damaged.</p> <p>G. Motor/pump does not work.</p>	<p>A. Check that the pump and heater are plugged in and that the GFCI or RCD is switched to the correct position. Plug in or reset the GFCI/RCD as needed.</p> <p>B. Check that the hose is connected at both the receiver/pump end and to the air switch. Reconnect if needed.</p> <p>C. Adjust hose to clear the pinched/kinked area. If the tubing is pinched/kinked and cannot be readjusted, or no noticeable pinch/kink is apparent, poke a small hole in the tubing with a tack and try the system again.</p> <p>D. Replace the push button assembly.</p> <p>E. Disassemble the push button assembly and wipe away any excess grease. Reassemble the button and retry the system.</p> <p>F. Replace the air hose.</p> <p>G. Replace the motor/pump.</p>
2. Motor starts, not all jets are functioning.	<p>A. Jet is closed.</p> <p>B. Jet not installed correctly.</p> <p>C. Jets are blocked.</p>	<p>A. Rotate jet trim ring counterclockwise to open.</p> <p>B. Reinstall jet; check for O-ring damage.</p> <p>C. Remove blockage.</p>
3. Pump does not prime.	<p>A. Pump shimmed too high.</p>	<p>A. Lower pump support bracket.</p>
4. Noisy operation.	<p>A. Pump banding straps have not been cut. (Models with support blocks only.)</p> <p>B. Jet O-ring dislodged.</p>	<p>A. Cut pump banding straps with tin snips.</p> <p>B. Remove jet, replace and lubricate O-ring, and reinstall jet.</p>
5. Heater does not operate. ("H" models only)	<p>A. No power to heater.</p> <p>B. Water temperature exceeds 104°F (40°C).</p> <p>C. Heater does not work.</p>	<p>A. Reset the GFCI or RCD.</p> <p>B. Allow water to cool and heater will reengage.</p> <p>C. Replace heater.</p>