

Features

- Brass construction
- Fixture-mount design
- Includes four 1.5 V AA batteries
- Electronic infrared sensor with TriPoint™ technology for accurate activation
- Intended for urinal installations with 3/4" spud coupling connection
- Retrofit models require a control stop and vacuum breaker
- 1.0 gpf (3.8 lpf) flow rate
- Slow-closing piston technology

Codes/Standards Applicable

Specified model meets or exceeds the following:

- ADA
- ICC/ANSI A117.1
- CSA B651
- OBC
- ASME A112.18.1/CSA B125.1
- CSA B64
- ASSE 1037
- FCC 47, Part 15
- EN 55022
- Canadian ICES-003 class B

**EXPOSED FLUSHOMETER
K-10960**

ALSO K-10961, K-10965, K-10966

ADA **CSA B651** **OBC**

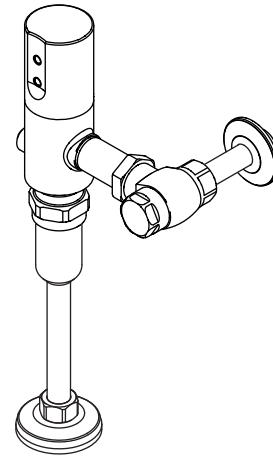

Colors/Finishes

- CP: Polished Chrome

Specified Model

Model	Description	Colors/Finishes
K-10960	Exposed flushometer – 1.0 gpf (3.8 lpf), washdown with TriPoint™ technology	<input type="checkbox"/> CP
K-10965	Exposed flushometer (retrofit) – 1.0 gpf (3.8 lpf), washdown with TriPoint technology	<input type="checkbox"/> CP
K-10961	Exposed flushometer – 1.0 gpf (3.8 lpf), siphon with TriPoint technology	<input type="checkbox"/> CP
K-10966	Exposed flushometer (retrofit) – 1.0 gpf (3.8 lpf), siphon with TriPoint technology	<input type="checkbox"/> CP

Product Specification

The exposed flushometer shall be made of brass construction. Flushometer shall feature electronic infrared sensor with TriPoint technology for accurate activation. Flushometer shall be of a fixture-mount design. Flushometer is intended for urinal installations with a 3/4" spud coupling connection, and retrofit models require a control stop and vacuum breaker. Flushometer shall have a 1.0 gpf (3.8 lpf) flow rate and slow-closing piston technology. Flushometer shall include four 1.5 V AA batteries. Exposed flushometer shall be Kohler Model K-_____-CP.

Technical Information

Recommended operating pressure:
25 psi (172 kPa) flowing - 80 psi (552 kPa) static*
* Pressure over 80 psi (552 kPa) is not recommended on most plumbing fixtures.

Installation Notes

Install this product according to the installation guide.

IMPORTANT! Maintain a 6" (152 mm) minimum critical level above the fixture.

ADA, CSA B651, OBC compliant when installed to the specific requirements of these regulations.

*11-3/8" (289 mm) minimum with a 6" (152 mm) critical level above the fixture

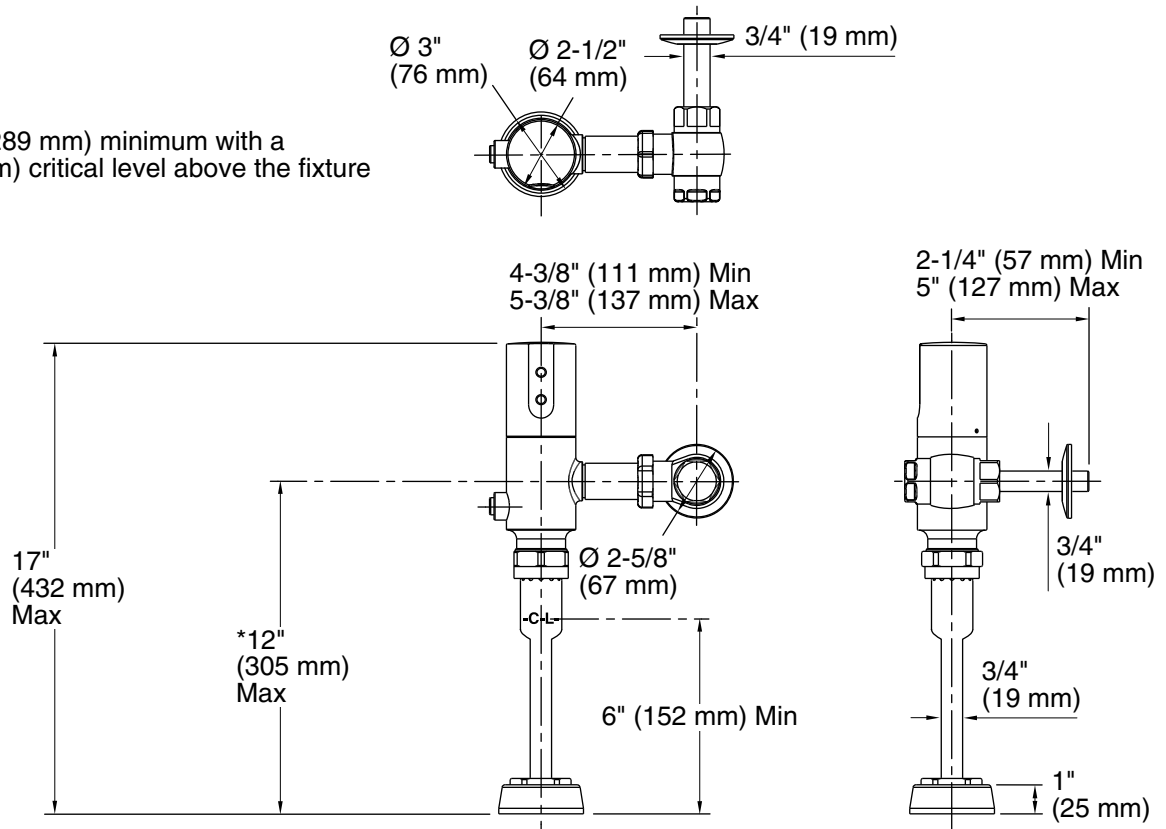

Product Diagram