

Installation and Assembly - Armor Lock Plus™ Security Cable with lock for the Vector Pro™, Vector Pro Plus™, Encore™ or PRS-1 Projector Mounts

Model: ACC 020

IMPORTANT! Read entire instruction sheet before you start installation and assembly.

Before you start check the parts list below to make sure all of the parts shown are included.

Parts List

Description	Qty.	Part Number
AA cable assembly, with loop end	1	600-0032
BB 4 mm security allen wrench	1	560-9646
CC #10-32 serrated washer head socket pin screw	2	510-1121
DD cable adapter (for use with Encore Mounts only)	1	055-1010
EE PRS interface plate (for use with PRS-1 Mounts only)	1	580-1070

Note: Actual parts may appear slightly different than illustrated.

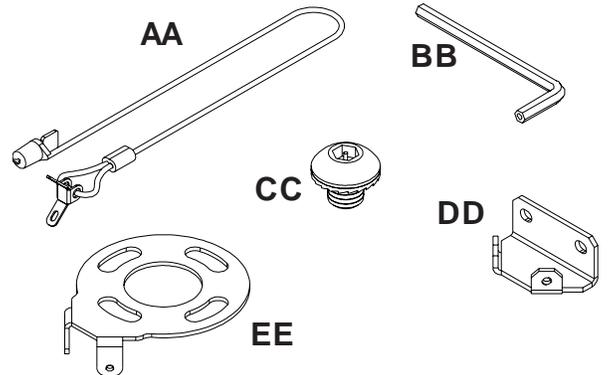

If installing the security cable onto an Encore Mount, skip to step 2.

If installing the security cable onto an PRS-1 Mount, skip to step 4.

1

If installing the security cable onto a Vector Pro and Vector Pro Plus Mount, align holes of bracket from cable assembly (AA) to holes on PJC 100 as shown in detail 1. Fasten cable assembly (AA) to PJC 100 with two #10-32 serrated washer head socket pin screws (CC), and tighten using 4 mm security allen wrench (BB).

Insert key into lock. Then insert lock into slot on projector and turn key counterclockwise 90° to lock. Remove key.

Note: If needed, when installing the cable assembly (AA), wrap the cable around the PJC 100 to reduce slack in the cable.

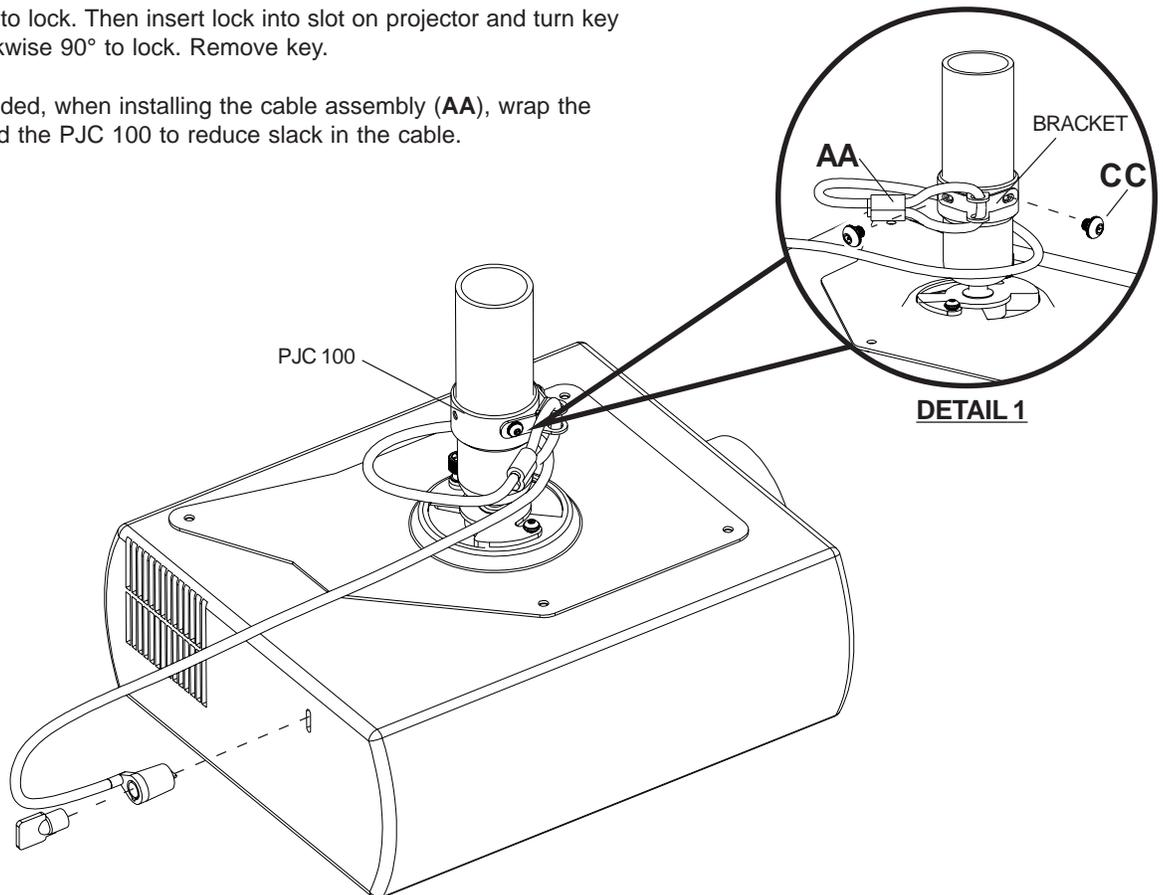

2 If installing the security cable onto an Encore Mount, remove two 20 mm screws from PJRL 411 assembly as indicated below. Attach cable adapter (DD) using existing 20 mm screws.

Note: The cable can be attached to the Encore Mount on either of the four sides of the PJRL 411.

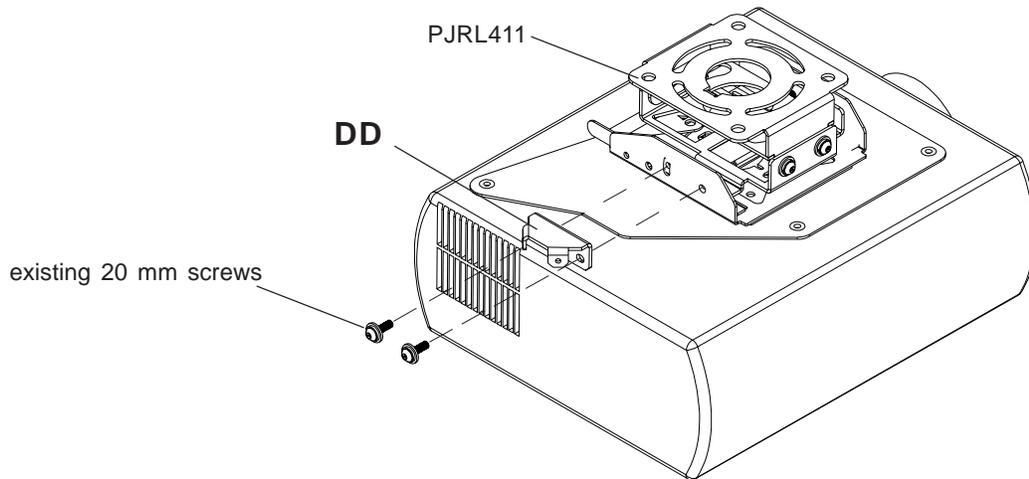

3 Align holes of bracket from cable assembly (AA) to holes on cable adapter (DD) as shown in detail 2. Fasten cable assembly (AA) to cable adapter (DD) with two #10-32 serrated washer head socket pin screws (CC), and tighten using 4 mm security allen wrench (BB).

Insert key into lock. Then insert lock into slot on projector and turn key counterclockwise 90° to lock. Remove key.

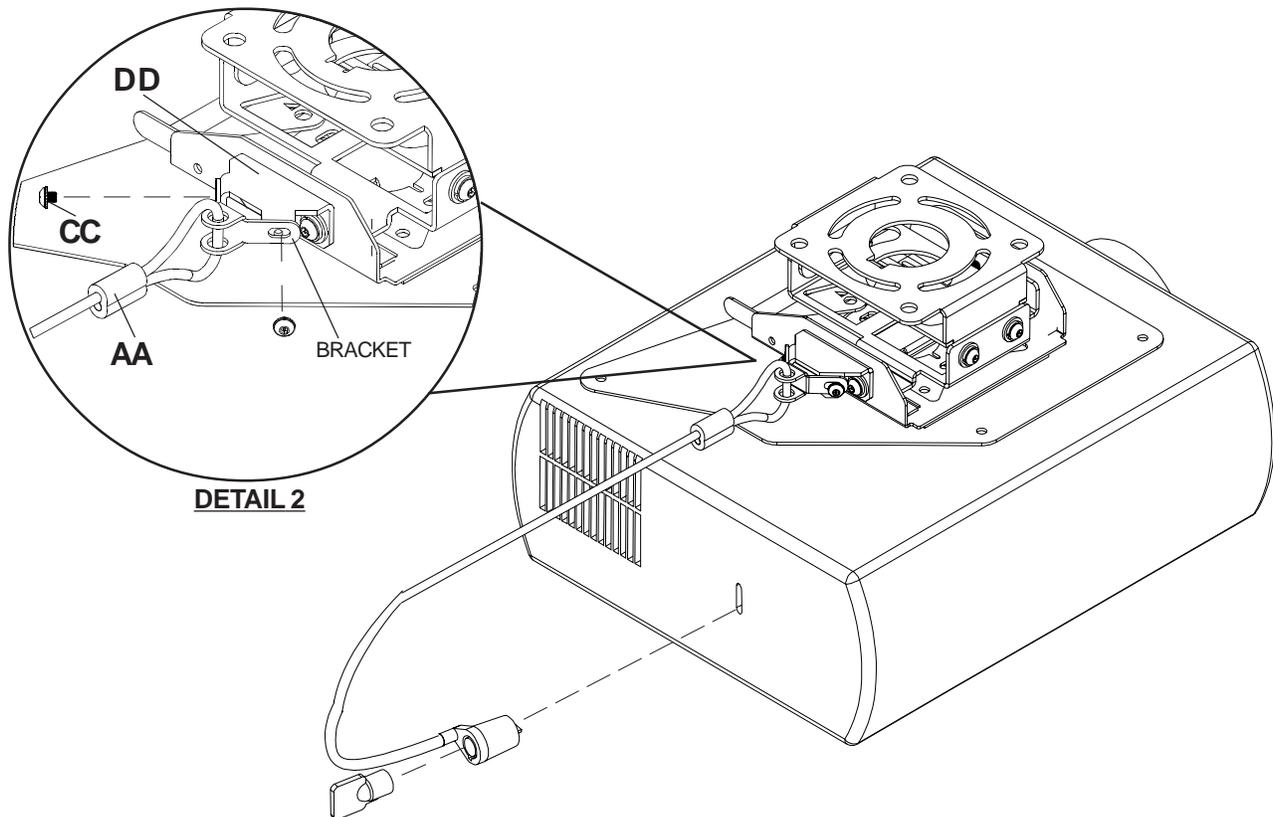

- 4** If installing the security cable onto a PRS-1, place PRS interface plate (EE) on top on PRS-1 mount, making sure that all slots are aligned. Then mount using instructions provided with PRS-1 mount.

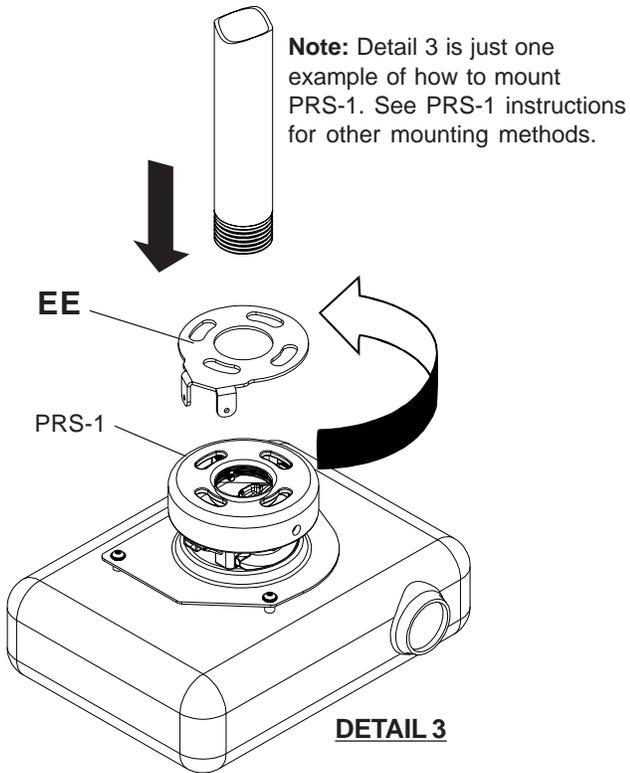

- 6** Insert key into lock. Then insert lock into slot on projector and turn key counter-clockwise 90° to lock. Remove key.

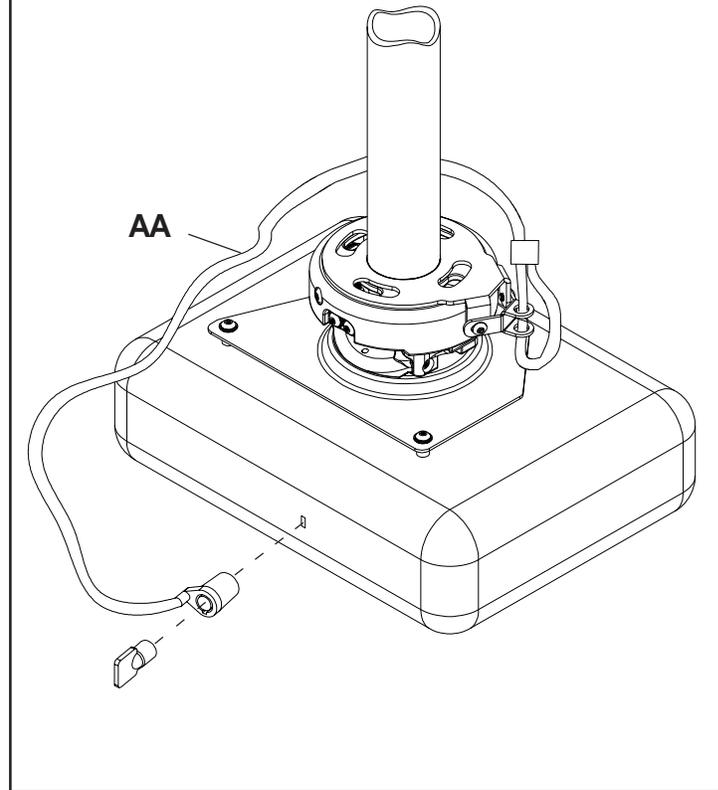

- 5** Fasten cable assembly (AA) to PRS interface plate (EE) with two #10-32 serrated washer head socket pin screws (CC), and tighten using 4 mm security allen wrench (BB).

