

IMPORTANT! Read entire instruction sheet before you start assembly and installation.

Parts List

Before you start make sure all parts listed are included with your product.

PART #	QTY.	DESCRIPTION
A	200-1434	1 rotation box
B	200-1285	1 tilt pivot retainer assembly
C	520-1055	2 10-32 x 1/2" socket pin screw
D	200-0288	1 pitch roll assembly
E	520-1001	1 carriage bolt 3/8"-16 x 3"
F	520-9263	12 M10 x 1.5 x 15 mm penta-pin screw
G	590-1087	1 tilt adjustment knob
H	520-9250	4 M5 x .8 x 10 mm phillips screw
I	200-1311	1 swivel lock bracket
J	200-0342	1 wall arm assembly
K	520-9260	1 M10 x 2" penta-pin™ driver
L	200-1338	1 wall plate
M	590-0097	4 concrete anchor
N	540-1008	4 fender washer
O	5SI-015-C03	4 wood screw
P	560-9646	1 4 mm security allen wrench

Note: Some parts may appear slightly different than illustrated.

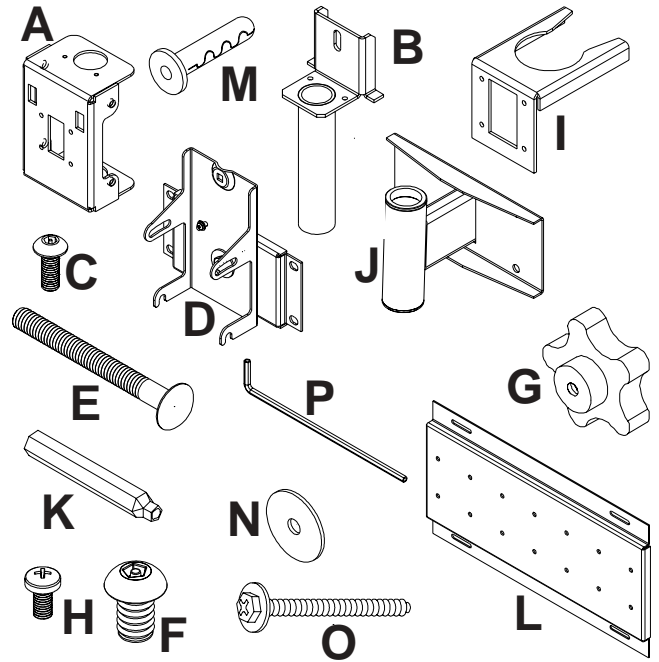

Note: Lay flat on surface for ease of assembly.

- 1** Place swivel lock bracket (I) on wall arm assembly (J) as shown to the right.
- 1-1** Place rotation box (A) with threaded holes up over wall arm assembly (J). Insert tilt pivot retainer assembly (B) through rotation box (A) and wall arm assembly (J).
- 1-2** Secure rotation box (A) to swivel lock bracket (I) using four M5 x .8 x 10 mm phillips screws (H). Align holes in tilt pivot retainer assembly (D) with holes in rotation box (B) and secure with two 10-32 x 1/2" socket pin screws (C) as shown.

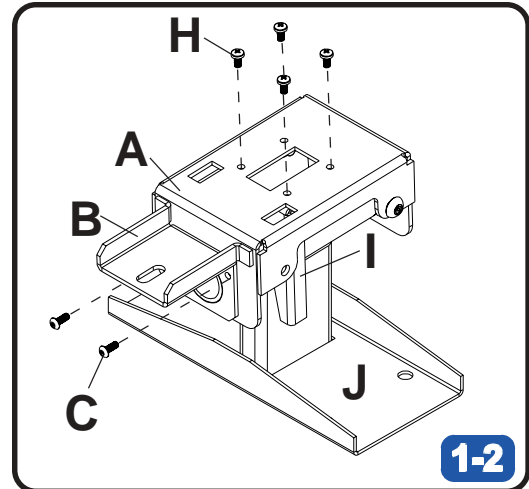
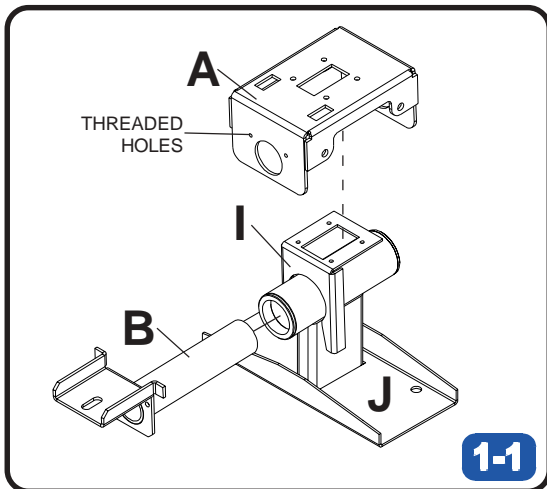
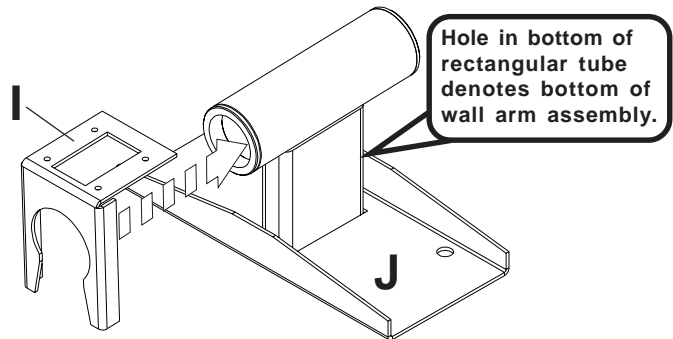

NOTE: Refer to adapter plate instruction sheet (not included with PS-1) for attachment of adapter plate to plasma before proceeding with step 2.

2 Insert and tape carriage bolt (E) into top hole of pitch roll assembly (D). Attach pitch roll assembly (D) to adapter bracket with four M10 penta-pin screws (F). Tighten M10 screws with penta-pin driver (K).

Note: Adapter bracket may be ordered separately and will vary in size and style.

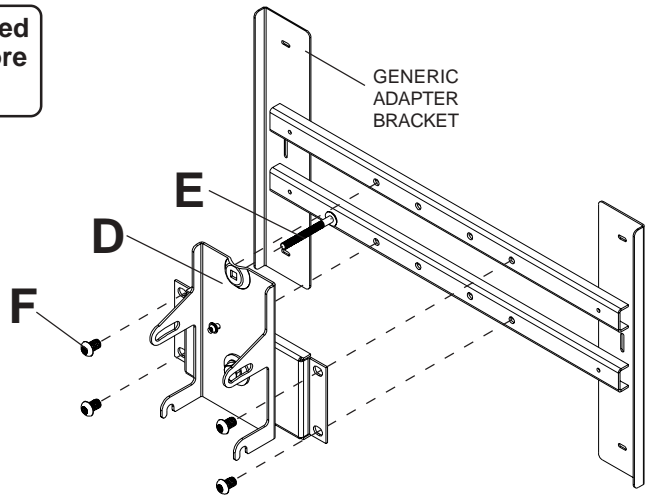

**OPTIONAL:
PLASMA IN VERTICAL POSITION**

DO NOT REMOVE M5 SCREWS. For vertical orientation, unscrew two M5 screws until screw is able to move freely in slot of tilt bracket as shown in details 4 and 4A. Hold adapter bracket stationary and rotate tilt bracket 90° by hand or using a lever (example: wood 2 x 4). Align M5 screws with threaded holes on bracket and tighten two M5 screws back into bracket.

CAUTION

- Do not overtighten screws. Overtightening may hinder roll option.

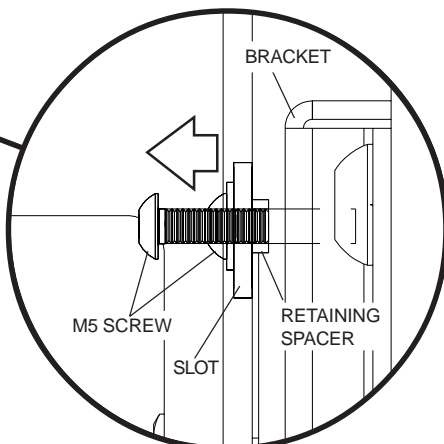
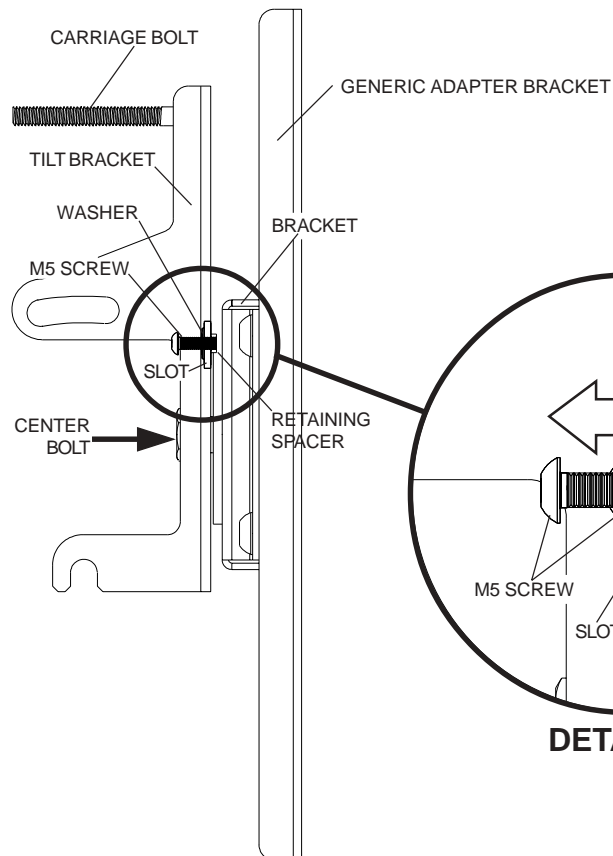
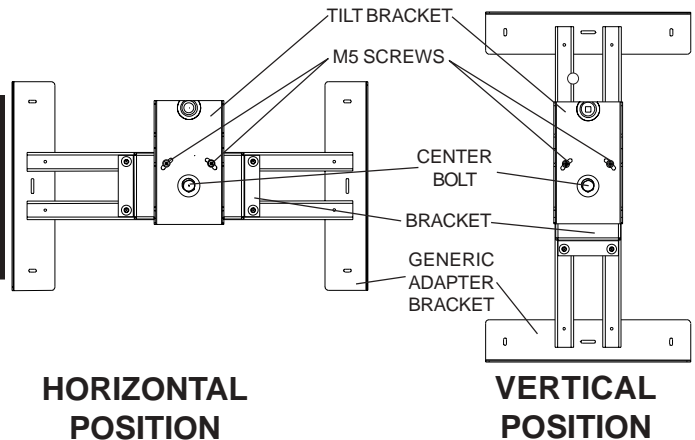

DETAIL 4

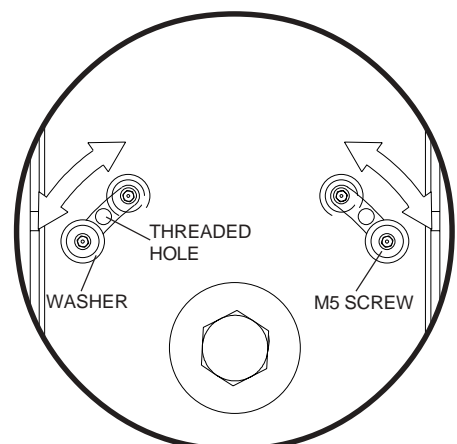

DETAIL 4A

- 3** Use stud finder to locate stud centers. Place wall plate (L) on wall as template, level wall plate and mark center of studs with pencil. The wall plate can be mounted on 16" centers. When mounted to 16" studs, the wall plate can be shifted 4" left or right of center if desired.

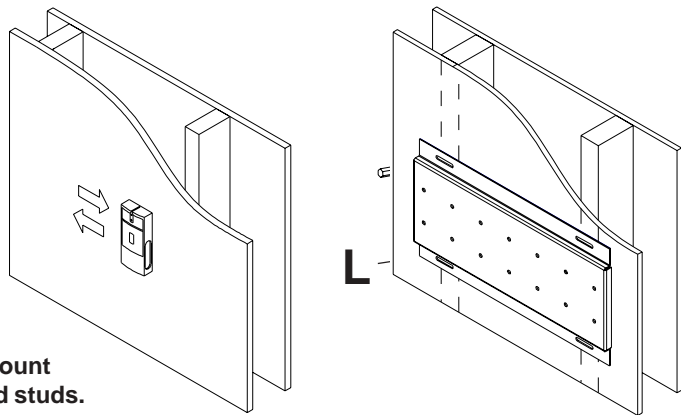

- 4** **Note: Hardware provided is for attachment of plasma mount through standard thickness drywall or plaster into wood studs. Installers are responsible to provide hardware for other types of mounting situations.**

For Wood Stud Walls drill four 5/32" (4 mm) dia. holes 2 1/2" (65 mm) deep. Attach wall plate (L) using four #14 x 2.5" (6 mm x 65 mm) wood screws and washers (O & N).

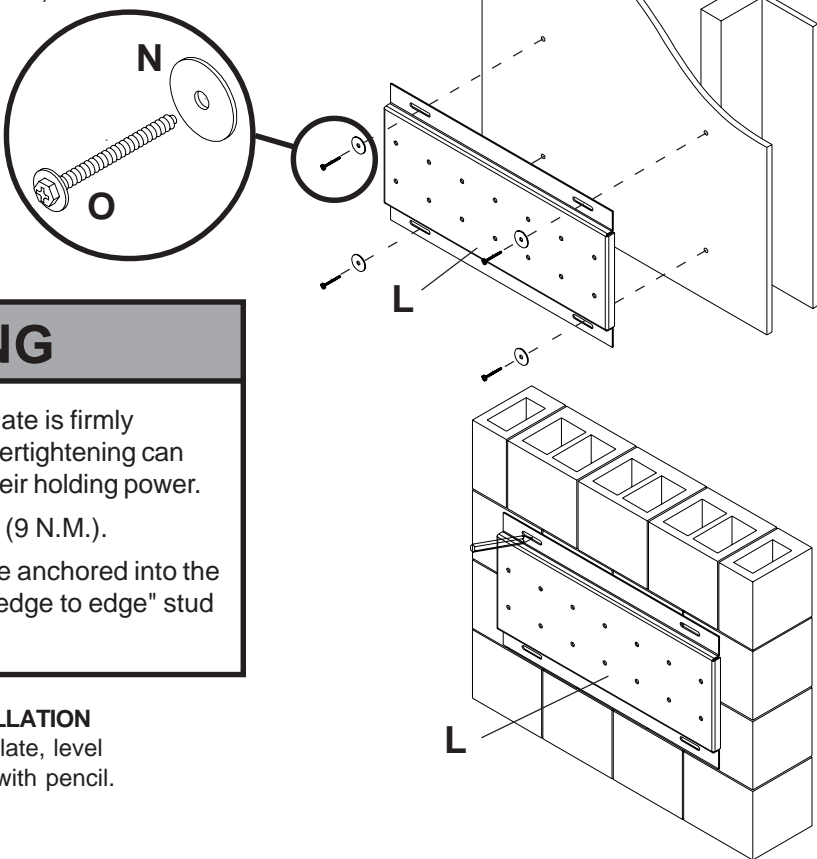

⚠ WARNING

- Tighten wood screws so that wall plate is firmly attached, but do not overtighten. Overtightening can damage screws, greatly reducing their holding power.
- Never tighten in excess of 80 in • lb (9 N.M.).
- Make sure that mounting screws are anchored into the center of the studs. The use of an "edge to edge" stud finder is highly recommended.

- 5** **CONCRETE/CINDER BLOCK INSTALLATION**
Place wall plate (L) on wall as template, level wall plate and mark center of slots with pencil.

⚠ WARNING

- When installing Peerless wall mounts on cinder block, verify that you have a minimum of 1 5/8" of actual concrete surface in the 1/4" diameter hole to be used for the concrete anchors. Do not drill into mortar joints! Be sure to mount in a solid part of the block, generally 1" minimum from the side of the block. Cinder block must meet ASTM C-90 specifications. It is suggested that a standard electric drill on slow setting is used to drill the hole instead of a hammer drill to avoid breaking out the back of the hole when entering a void or cavity.
- Concrete must be 2000 psi density minimum. Lighter density concrete may not hold concrete anchor.
- Make sure that the wall will safely support 4 times the combined load of the equipment and all attached hardware and components.

- 6** For **Concrete Walls** drill four 1/4" (6 mm) dia. holes to a minimum depth of 2.5" (64 mm) on marks made in step 1. Insert anchor (**M**) in holes flush with wall as shown (right). Place wall plate (**L**) over anchor and secure with four #14 x 2.5" (6 mm x 65 mm) wood screws and washers (**O** & **N**) as shown at bottom of page. Make sure wall plate is level before placing fasteners. Tighten all fasteners.

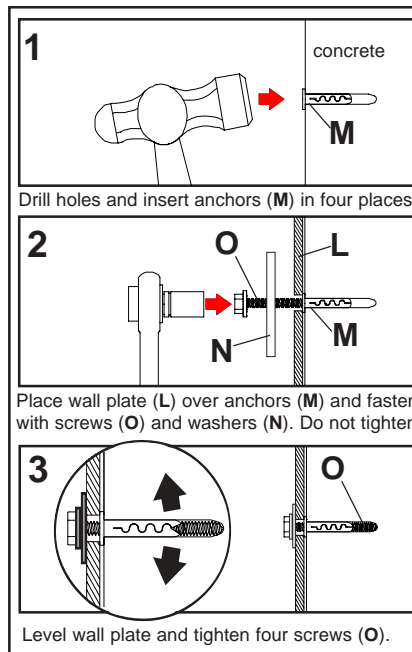

⚠ WARNING

- Tighten wood screws so that wall plate is firmly attached, but do not overtighten. Overtightening can damage screws, greatly reducing their holding power.
- Never tighten in excess of 80 in • lb (9 N.M.).

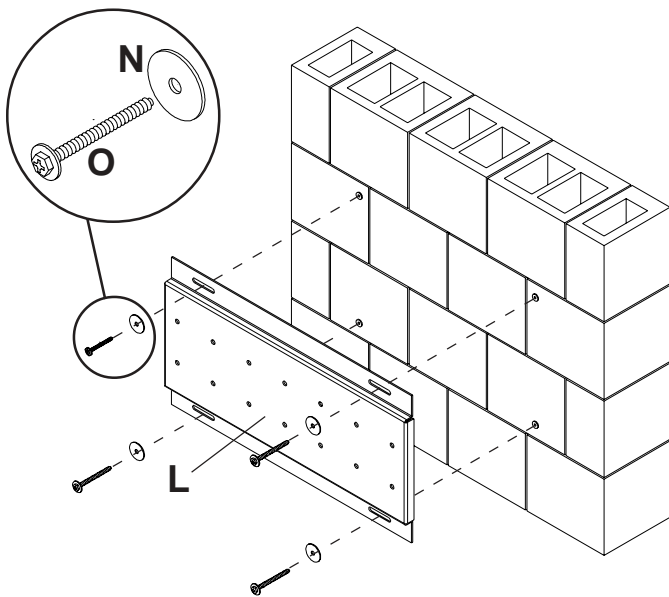

⚠ WARNING

- Always attach concrete expansion anchors directly to load-bearing concrete.
- Never attach concrete expansion anchors to concrete covered with plaster, drywall, or other finishing material.

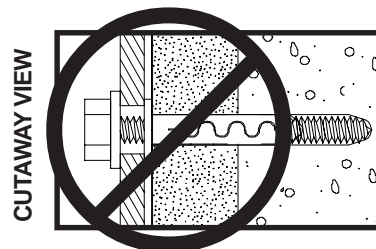

- 7** **NOTE: Five mounting positions, center position shown to the right.**

Attach wall arm assembly (**J**) to wall plate (**L**) using four M10 penta-pin screws (**F**).

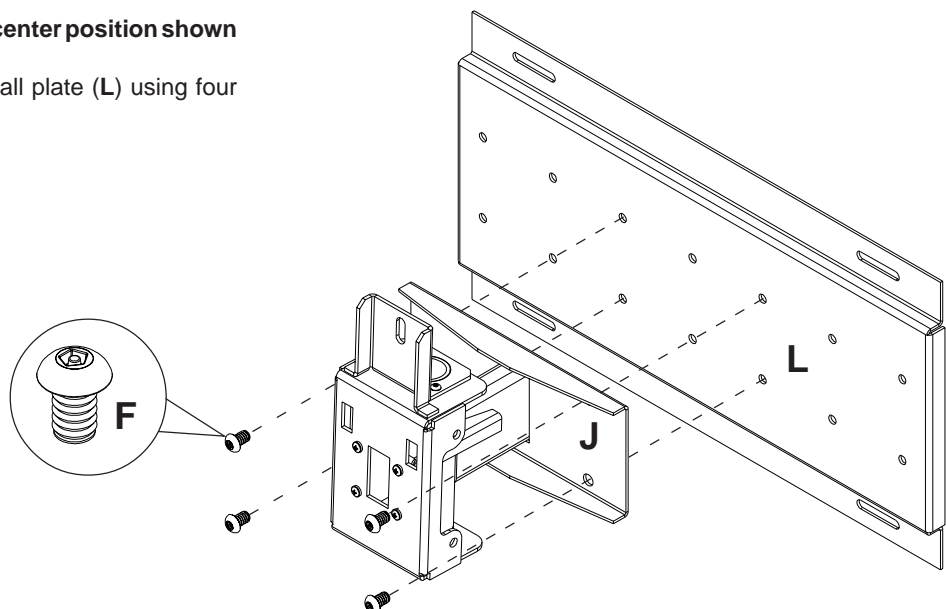

8

Insert two M10 penta-pin screws (F) into rotation box (A) as shown. Leave approx. 1/4" of exposed thread.

⚠ WARNING

- Always use an assistant or mechanical lifting equipment to safely lift and position the plasma television.

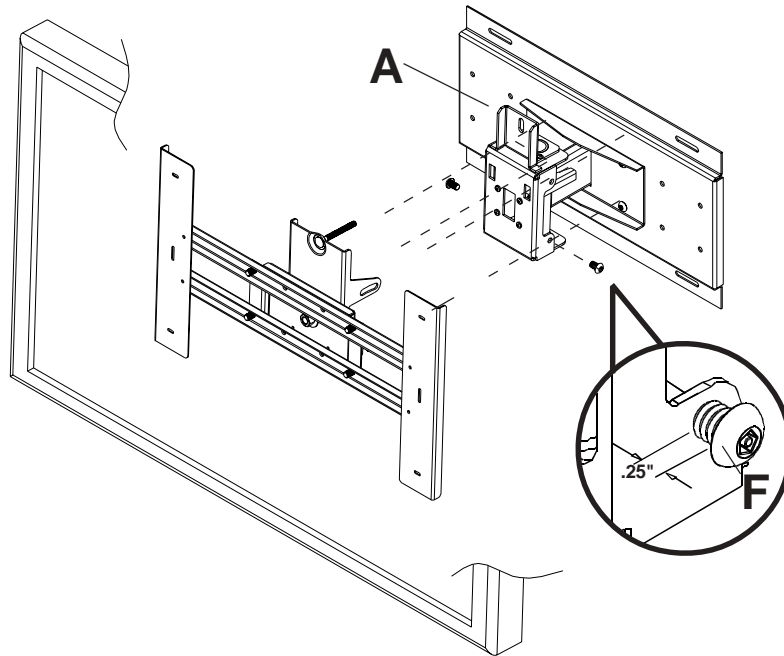

8-1 Hook pitch roll assembly (D) onto M10 penta-pin screws (F). Insert carriage bolt (E) into slot of tilt pivot retainer assembly (B) as shown. Install tilt adjustment knob (G).

8-2 Install remaining two M10 penta-pin screws (F). **HAND TIGHTEN** all four M10 penta-pin screws (F) to allow for tilt adjustment. Remove tape from carriage bolt (E). For tilt adjustment, gently push back on the top of plasma to relieve pressure on knob. Adjust tilt to desired position and tighten tilt adjustment knob (G), then securely tighten all four M10 screws (F) using penta-pin driver (K).

AS A FINAL PRECAUTION, CHECK ALL FASTENERS AND TIGHTEN SECURELY.

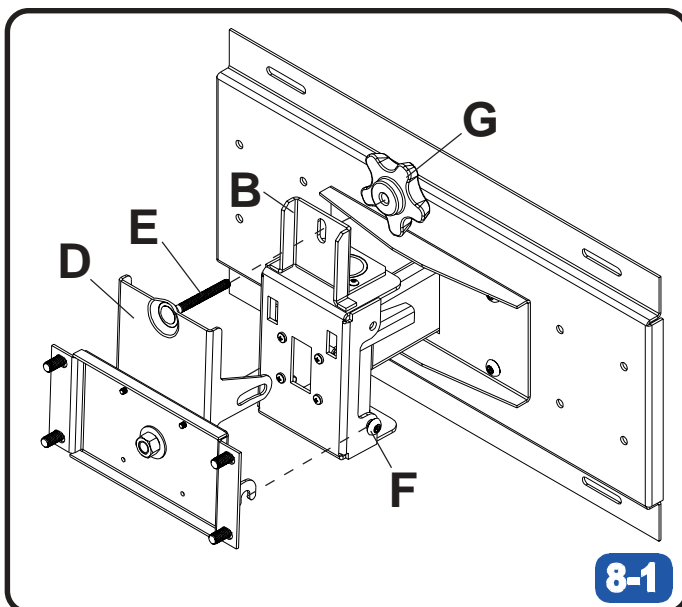
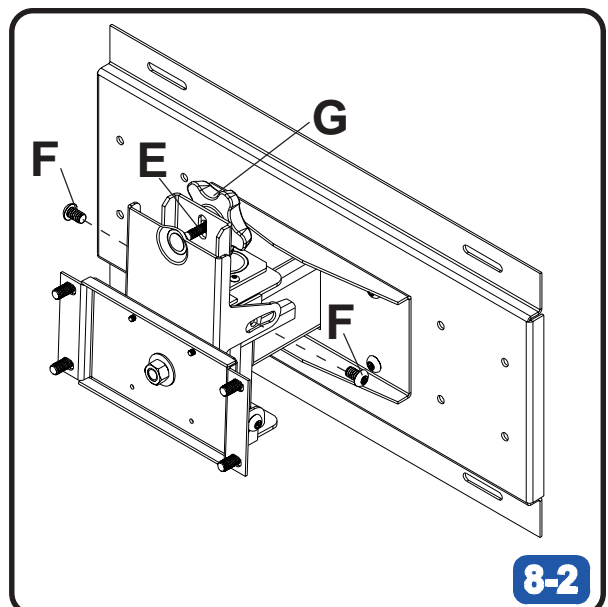
**8-1****8-2**

NOTE: Refer to page four of accompanying instruction sheet for attachment of PS 1 with plasma to wall plate before proceeding with step 4.

- 9** Depending on the specific size & weight of the plasma, plasma may appear to lean sideways. Pitch roll assembly (D) allows plasma to be manually adjusted, so plasma can be horizontal. To adjust, gently rotate plasma by hand to desired position.

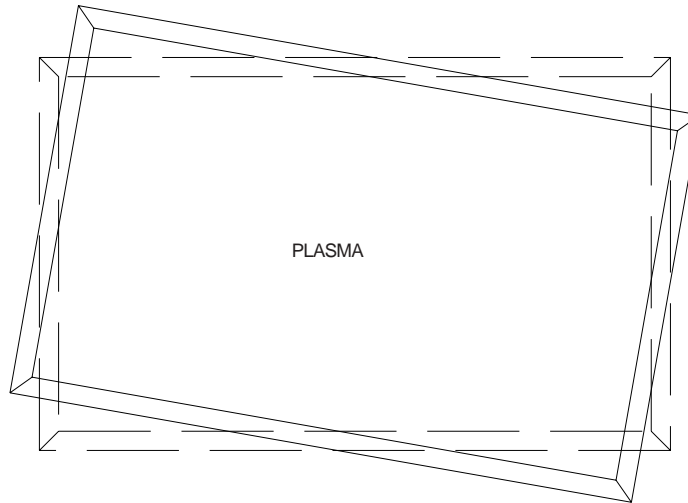

IMPORTANT! Center bolt is factory torqued for optimal performance to adjust for range of plasma sizes.

If it is too difficult to adjust roll of plasma, torque may be adjusted by following the procedures below.

- 9-1** Adjust tilt adjustment knob (G) to allow maximum tilt.

- 9-2** Insert 3/4" open-end wrench (not provided) into side of pitch roll assembly (D) and rotate center bolt counter-clockwise to loosen torque.

IMPORTANT! Do not loosen or tighten more than 1/8 turn.

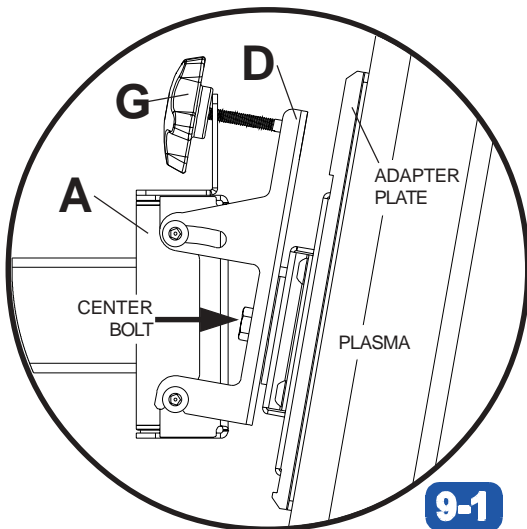

9-1

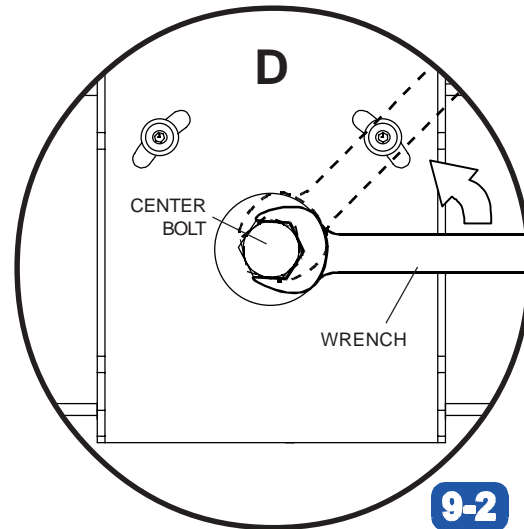

9-2