

**Installation and Assembly - Universal Articulating
Swivel Arm for 32" - 50" Plasma Screens**

**Models: PLA 50-UNL, PLA 50-UNL-S,
PLA 50-UNLP, PLA 50-UNLP-S,
RTPLA50-S**

Maximum Load Capacity: 150 lb (68 kg)

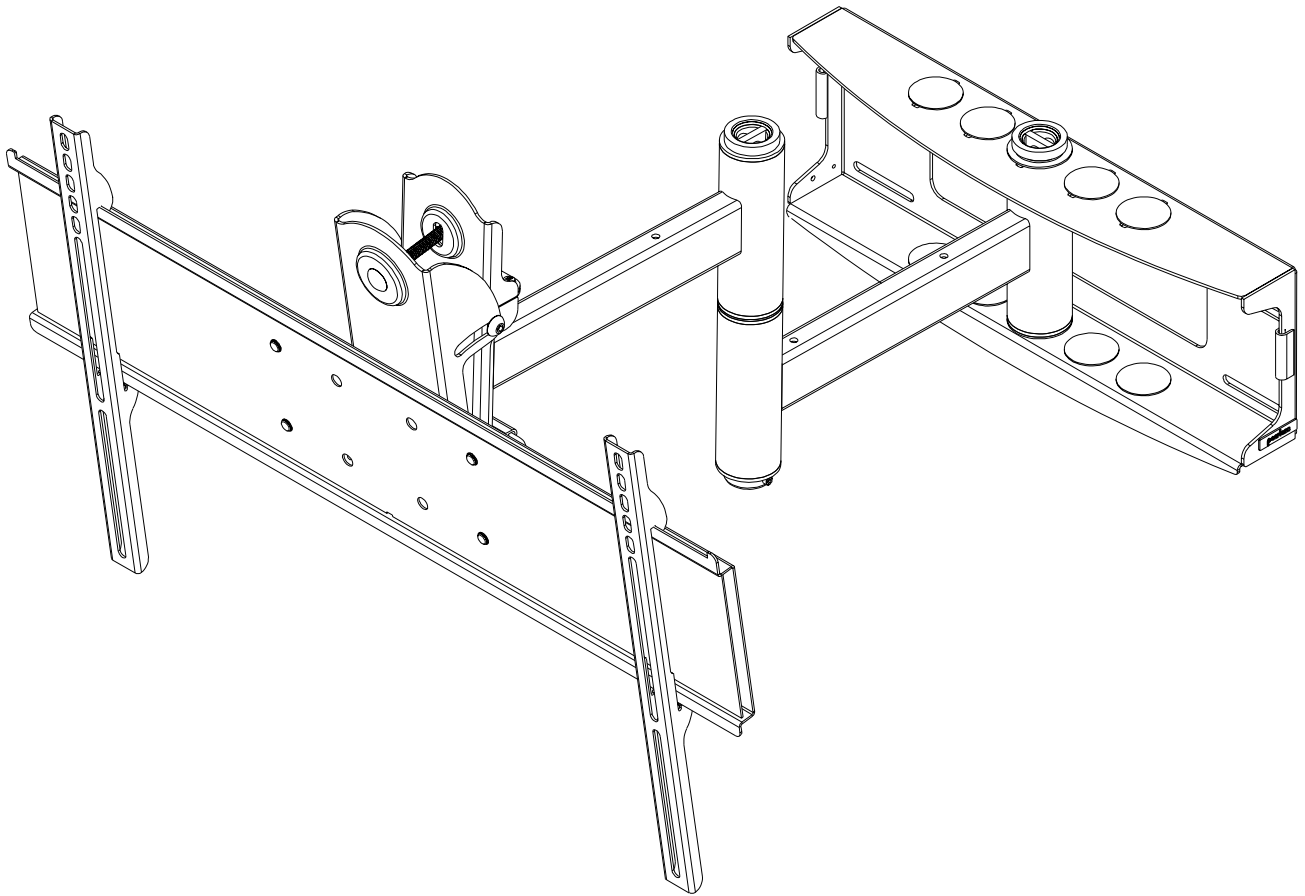

Read instruction sheet before you start installation and assembly.

⚠ WARNING

- Do not begin to install your Peerless product until you have read and understood the instructions and warnings contained in this Installation Sheet. If you have any questions regarding any of the instructions or warnings, please call Peerless customer care at 1-800-729-0307.
- This product should only be installed by a qualified professional.
- Make sure that the supporting surface will safely support the combined load of the equipment and all attached hardware and components.
- Never exceed the Maximum Load Capacity of 150 lb (68 kg).
- Never mount this product to metal studs.
- If mounting to wood wall studs, make sure that mounting screws are anchored into the center of the studs. Use of an "edge to edge" stud finder is highly recommended.
- Always use an assistant or mechanical lifting equipment to safely lift and position equipment.
- Tighten screws and nuts firmly, but do not overtighten. Overtightening can damage the items, greatly reducing their holding power.

IMPORTANT! Certain types of walls require additional mounting hardware...

WALL CONSTRUCTION	ADDITIONAL HARDWARE REQUIRED
Wood Stud, Wood Beam	none
Solid Concrete	Contact Customer Care for accessory kit
Other or unsure?	Contact Customer Care

IMPORTANT! Turn to the appropriate page for your wall installation.

Installations:

To Wood Stud Walls	page 6
To Concrete Walls	page 7

Accessories

- concrete anchor 4-pack (ACC 210)

Tools Needed for Assembly

- stud finder ("edge to edge" stud finder is recommended)
- drill
- 3/16" drill bit for wood studs
- 5/16" drill bit for concrete
- 7/16" socket wrench with extension (recommended) for wood screws
- 10 mm socket wrench for concrete anchors
- level
- phillips screwdriver

Wall Mount Parts List

Before you start make sure all parts listed are included with your product.

DESCRIPTION	QTY.	MODEL	
		PART #	PART #
A wall plate	1	201-1095	201-4095
B tilt-roll assembly	1	201-1093	201-4093
C arm assembly	1	201-1094	201-4094
D wall support arm axle	1	201-1041	201-1041
E vinyl trim	3	600-1012	600-1012
F M10 x 1.5 x 15 mm screw bolt	8	520-9262	520-9262
G .505 x .75 x .062" nylon washer	1	540-1074	540-1074
H tilt adjustment knob	1	560-0108	560-0108
I carriage bolt 3/8"-16 x 3.25"	1	520-1315	520-1315
J 1.525 x 2 x .062" delrin washer	2	540-1070	540-1070
K #8-32 x .375" socket head cap screw	1	520-1210	520-1210
L plastic finishing cap	8	590-1123	590-1123
M holding pin	1	580-1166	580-1166
N retainer plug	1	590-1007	590-1007
O 5/16 x 3" wood screw	6	520-1243	520-1243
P .250 x 1 x .068" washer	6	540-1063	540-1063
Q 9/64" allen wrench	1	560-9728	560-9728
R cable management clips	4	590-1166	590-1166
S cable tie	4	590-1168	590-1168
T 36" polyester mesh sleeve	1	600-1015	600-1015
U 6 mm allen wrench	1	560-9716	560-9716

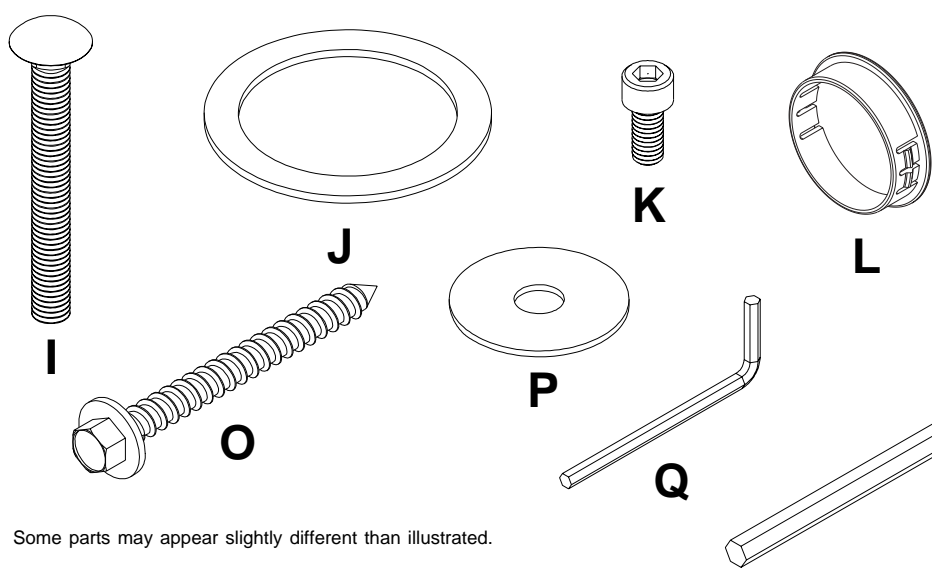
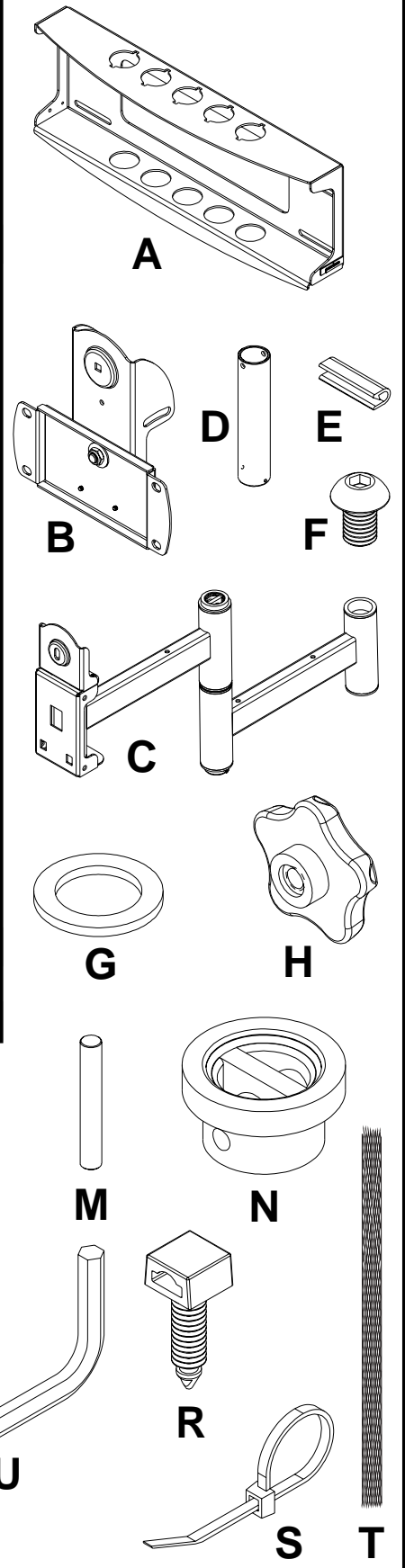

Some parts may appear slightly different than illustrated.

Before you begin, make sure all parts shown are included with your product.

Adapter Bracket Parts List

RTPLA50-S

Description	Qty	PLA 50-UNL	PLA 50-UNL-S	PLA 50-UNLP	PLA 50-UNLP-S
		Part #	Part #	Part #	Part #
AA adapter bracket	1	201-1110	201-4110	201-1110	201-4110
BB shallow adapter bracket	2	200-0756	200-0757	200-0754	200-0755
CC deep adapter bracket	2	200-0752	200-0753	200-0750	200-0751
DD allen wrench	1	560-9646	560-9646	560-0072	560-0072

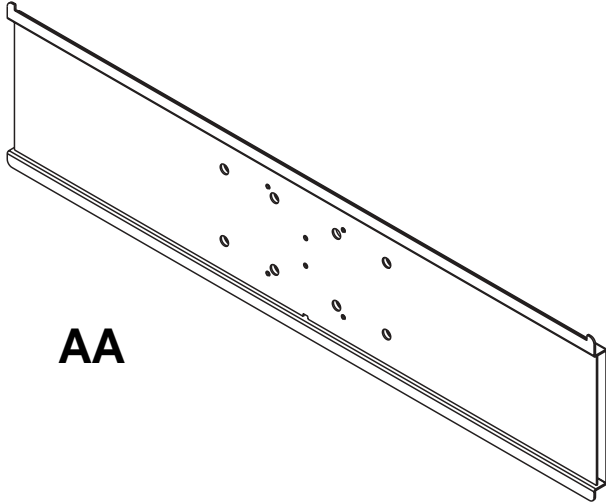

BB



CC

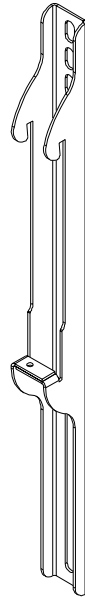

DD

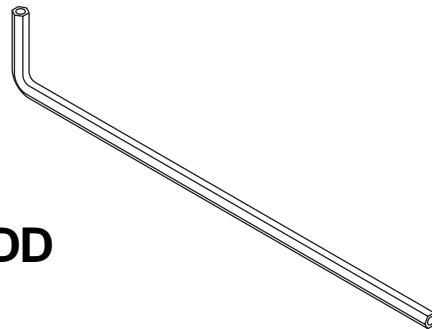

Security Adapter Bracket Fasteners



M4 x 12 mm (6)
510-1079

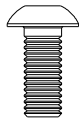

M5 x 12 mm (4)
520-1064

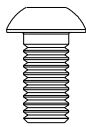

M6 x 12 mm (4)
520-1050

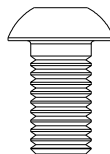

M8 x 15 mm (6)
520-1068



M6 x 20 mm (4)
520-9554

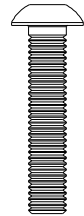

M5 x 25 mm (4)
520-1122

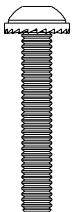

M4 x 25 mm (4)
510-1082

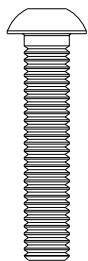

M6 x 30 mm (4)
520-1067

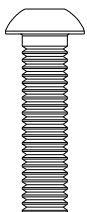

M6 x 25 mm (4)
520-1211

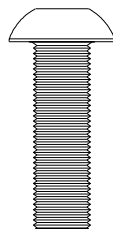

M8 x 25 mm (4)
520-1101

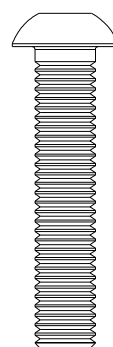

M8 x 40 mm (4)
520-1152

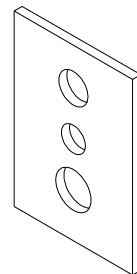

multi-washer (6)
580-1036

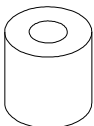

I.D. 5.6 mm (4)
540-1057

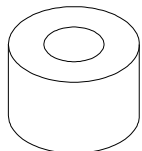

I.D. 8.7 mm (4)
540-1059

Phillips Adapter Bracket Fasteners

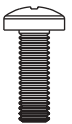

M4 x 12 mm (6)
504-9013

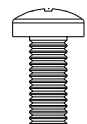

M5 x 12 mm (4)
520-1027

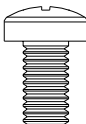

M6 x 12 mm (4)
520-1128

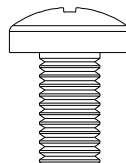

M8 x 16 mm (6)
520-9257

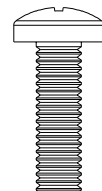

M6 x 20 mm (4)
520-9402

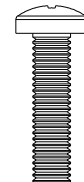

M5 x 25 mm (4)
520-9543



M4 x 25 mm (4)
504-1015

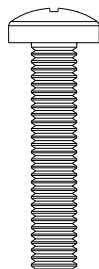

M6 x 30 mm (4)
510-9109

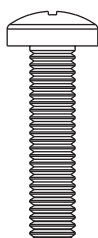

M6 x 25 mm (4)
520-1208

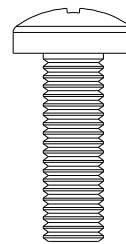

M8 x 25 mm (4)
520-1031

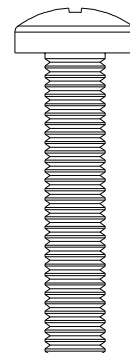

M8 x 40 mm (4)
520-1136

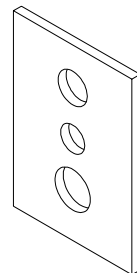

multi-washer (6)
580-1036

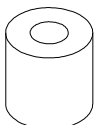

I.D. 5.6 mm (4)
540-1057

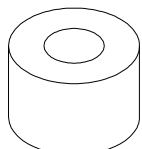

I.D. 8.7 mm (4)
540-1059

Installation to Wood Stud Wall

⚠ WARNING

- Installer must verify that the supporting surface will safely support the combined load of the equipment and all attached hardware and components.
- Tighten wood screws so that wall plate is firmly attached, but do not overtighten. Overtightening can damage the screws, greatly reducing their holding power.
- Never tighten in excess of 80 in. • lb (9 N.M.).
- Never mount this product to metal studs.
- Make sure that mounting screws are anchored into the center of the stud. The use of an "edge to edge" stud finder is highly recommended.
- Hardware provided is for attachment of mount through standard thickness drywall or plaster into wood studs. Installers are responsible to provide hardware for other types of mounting situations.
- Never exceed the Maximum Load Capacity of 150 lb (68 kg).

1 Wall plate (**A**) can be mounted to two studs that are 16" apart. Use a stud finder to locate the edges of the studs. Use of an edge-to-edge stud finder is highly recommended. Based on their edges, draw a vertical line down each stud's center. Place wall plate on wall as a template. The top mounting slots should be located 3.9" below the desired screen center. Level plate, and mark the center of the four mounting holes. Make sure that the mounting holes are on the stud centerlines. Drill six 3/16" (5 mm) dia. holes 3" (76 mm) deep. Make sure that the wall plate is level, secure it using six 5/16 x 3" wood screws (**O**) and washers (**P**).

Skip to step 2 on page 8.

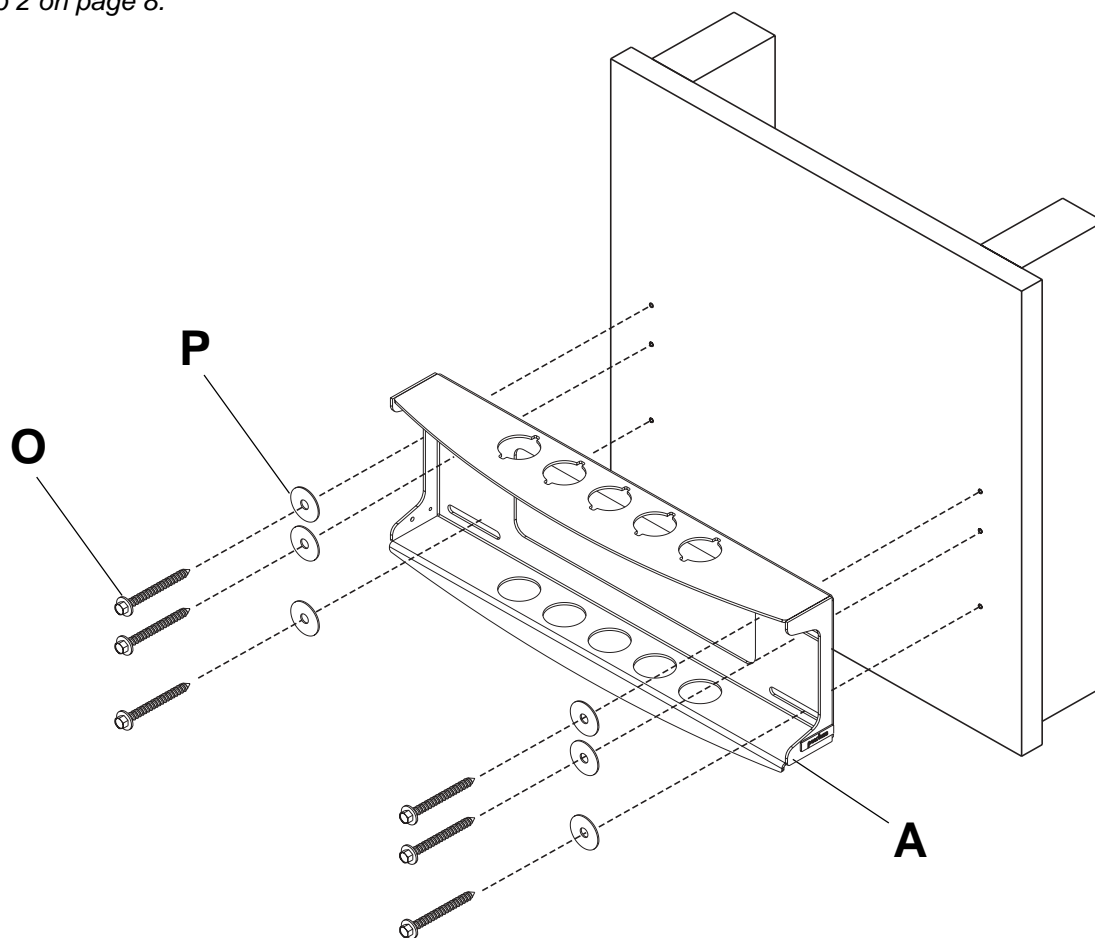

Installation to Concrete Wall

⚠ WARNING

- Concrete must be 2000 psi density minimum. Lighter density concrete may not hold concrete anchor.
- Make sure that the supporting surface will safely support the combined load of the equipment and all attached hardware and components.
- Never exceed the Maximum Load Capacity of 150 lb (68 kg).

Note: Fasteners for concrete walls are not included, order TWO #ACC 210 accessory kits for installation on concrete walls.

- 1** Make sure that wall plate (A) is level, use it as a template to mark six mounting holes. The top mounting slots should be located 3.9" below the desired screen center. Drill six 5/16" (8 mm) dia. holes to a minimum depth of 1.75" (45 mm). Attach wall plate (A) using concrete expansion anchors and washers (P) as shown in 1-1 through 1-4.
- 1-1** Align hole in wall plate (A) with hole in wall. Gently hammer in concrete anchor as shown.
- 1-2** Use a 10 mm wrench (not provided) to tighten concrete anchor to 80 in • lb (9 N.M.) maximum torque as shown.
- 1-3** **FOR PRODUCT SAFETY USE ONLY RAWL™ #5005 OR HILTI™ HL814 CONCRETE ANCHORS.** Order **TWO #ACC 210** accessory kits, each contains four .312 x 1.625 (8 mm x 41 mm) concrete expansion anchors.
- 1-4** Concrete expansion anchors are **not** intended for attachment to concrete covered with a layer of plaster, drywall, or other finishing material.

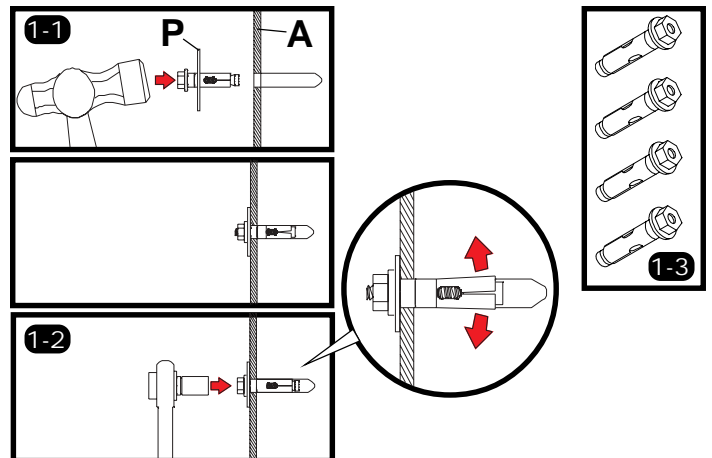
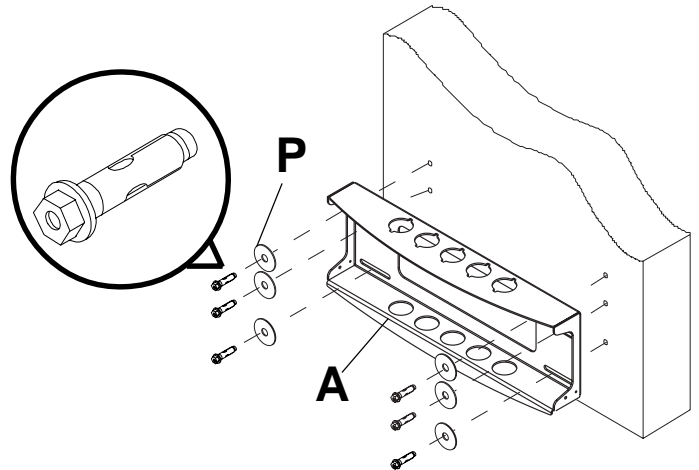

⚠ WARNING

- Tighten concrete anchor bolt firmly, but do not over-tighten. Overtightening can damage the bolt, greatly reducing its holding power.
- Never tighten in excess of 80 in • lb (9 N.M.).

⚠ WARNING

- Always attach concrete expansion anchors directly to load-bearing concrete.
- Never attach concrete expansion anchors to concrete covered with plaster, drywall, or other finishing material.

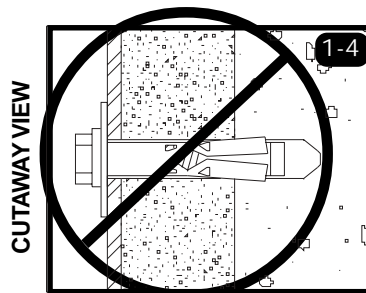

⚠ WARNING

- If you are uncertain that product is properly installed, call customer care.

2 **Note: There are five mounting positions. The center position is shown (right).** Slide washer (J) over wall support arm axle (D). Next, insert plastic cap (N) into axle. Then, insert holding pin (M) into axle. See detail 1.

2-1 Place arm assembly (C) with washer (J) into wall plate (A). Insert axle assembly shown in detail 1 through wall plate (A), arm assembly (C), and washer (J). Lock axle in place by aligning holding pin (M) with notches shown in detail 2.

2-2 Insert socket cap screw (K) into hole at bottom of wall support arm axle (D) as shown in detail 3. Tighten screw using 9/64" allen wrench (Q).

Note: Fit of axle (D) into wall plate (A) and arm assembly (C) will be tight. Gently tap into place with a hammer if necessary.

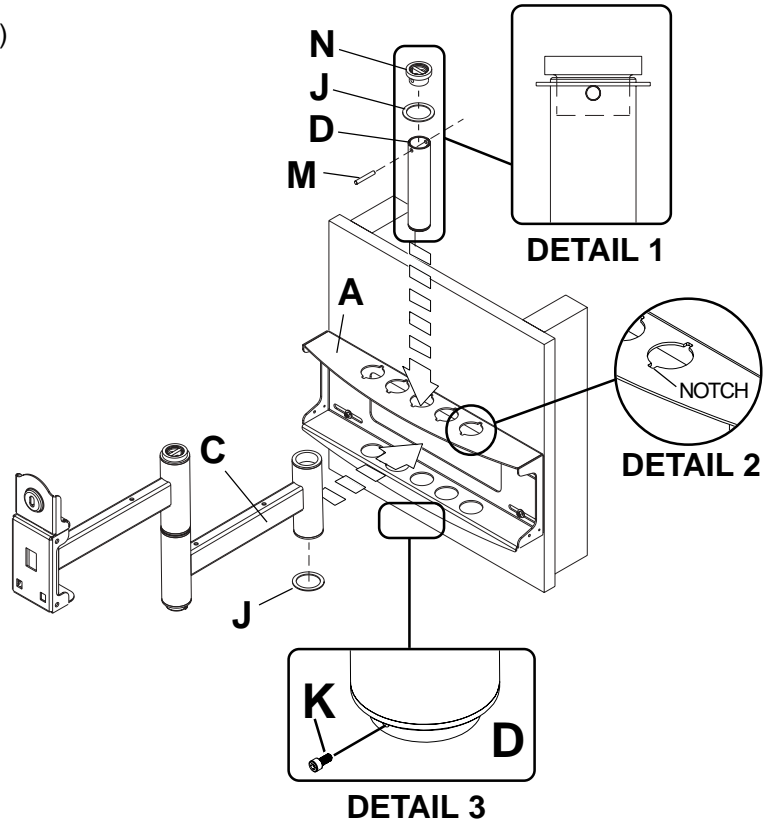

3 Snap four cable management clips (R) into top or bottom of arm assembly (C) as shown. Cable ties (S) are used with clips for cord management.

3-1 Slide one mesh sleeve (T) over each cable. Use cable ties (S) to tighten mesh sleeves to cables.

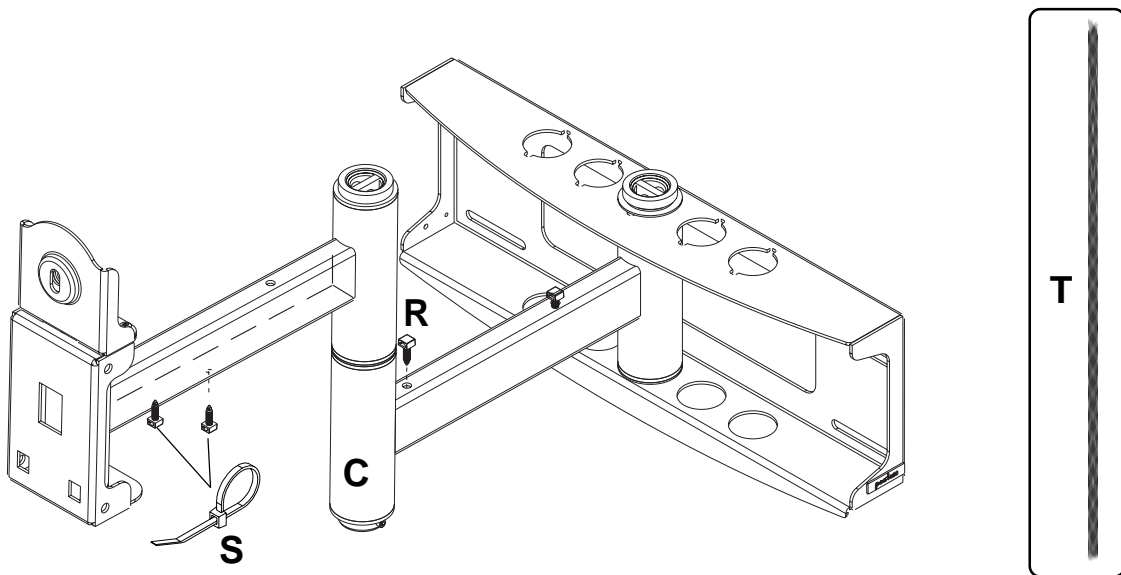

4 Attach two pieces of vinyl trim (E) to wall plate (A). Next, attach one piece of vinyl trim to bottom of swivel box on arm assembly (C).

4-1 Insert one finishing cap (L) into each unused hole of wall plate (A).

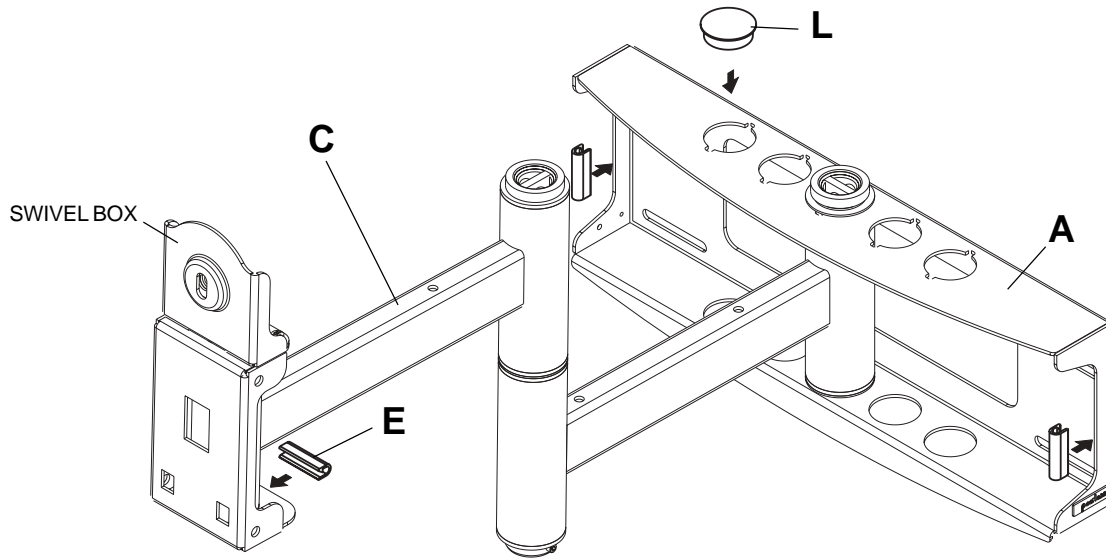

5 Insert and tape carriage bolt (I) into top hole of tilt-roll assembly (B). Attach tilt-roll assembly to adapter bracket (AA) with four M10 socket screws (F). Tighten screws using 6 mm allen wrench (U).

CAUTION

- Do not overtighten screws! Overtightening may hinder roll option.

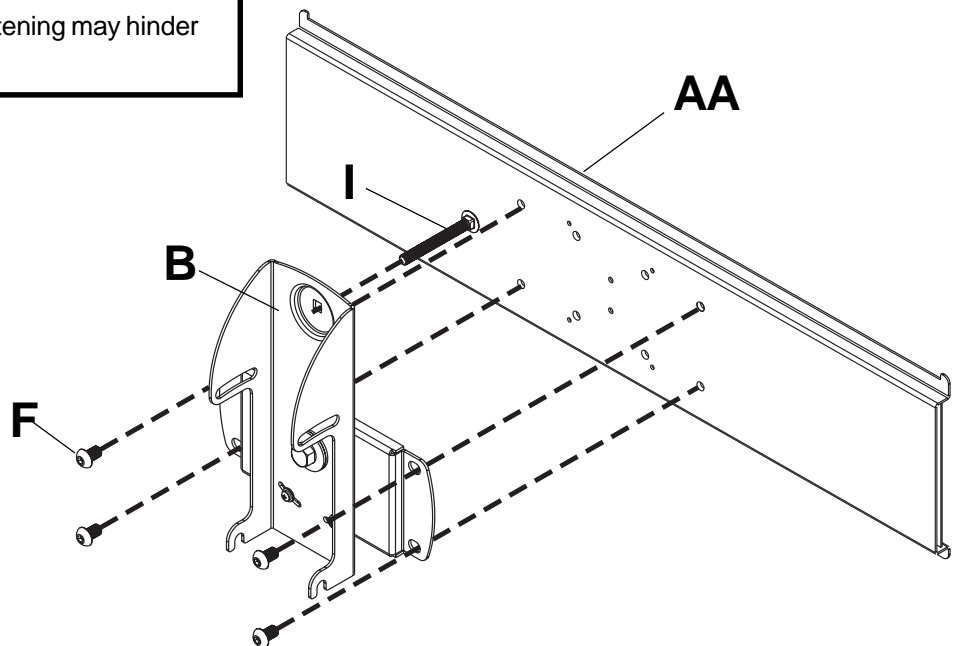

⚠ WARNING

- Use an assistant or mechanical lifting equipment to safely lift and position the plasma TV.

- 6** Insert two M10 screws (**F**) into swivel box on arm assembly (**C**) as shown. Leave approx. 1/4" of exposed thread.

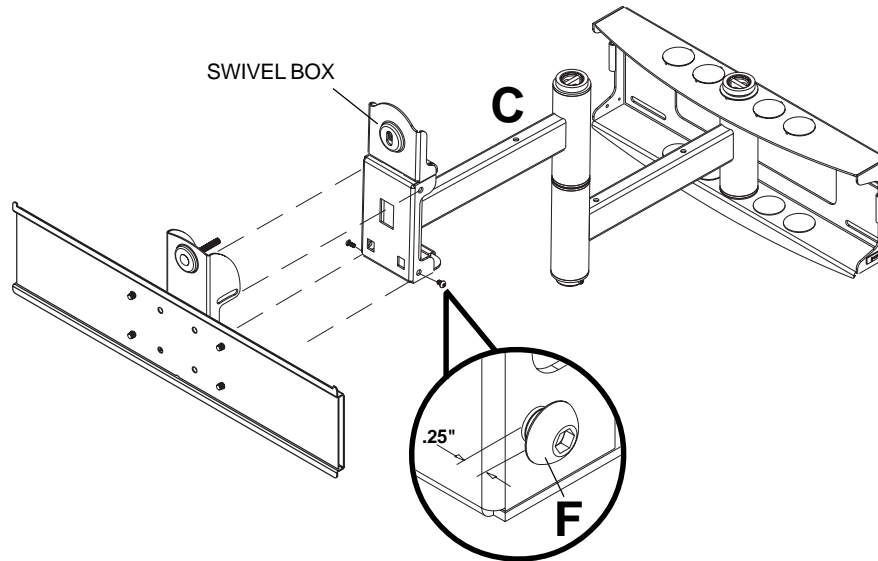

- 6-1** Hook tilt-roll assembly (**B**) onto M10 screws (**F**). Insert carriage bolt (**I**) into slot of swivel box as shown in figure 6.1. Install nylon washer (**G**) and tilt adjustment knob (**H**).

- 6-2** Install remaining two M10 screws (**F**) as shown in figure 6.2. **HAND TIGHTEN** all four M10 screws to allow for tilt adjustment. Remove tape from carriage bolt (**I**). For tilt adjustment, push back on the top of plasma to relieve pressure on knob. Adjust tilt to desired position and tighten tilt adjustment knob (**H**), then securely tighten all four M10 screws (**F**) using 6 mm allen wrench (**U**).

CAUTION

- After tilt is adjusted, all fasteners must be tightened. Failure to do so will result in damage to the mount.

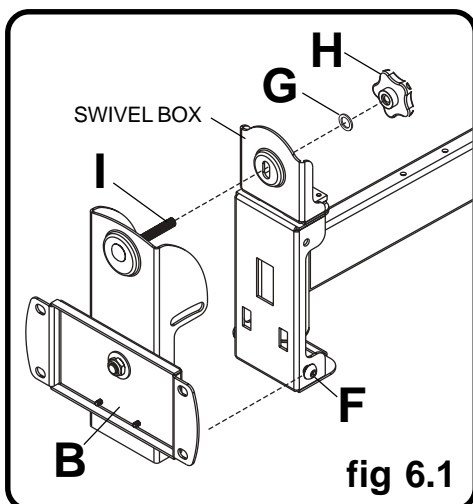

Adapter bracket not shown for clarity.

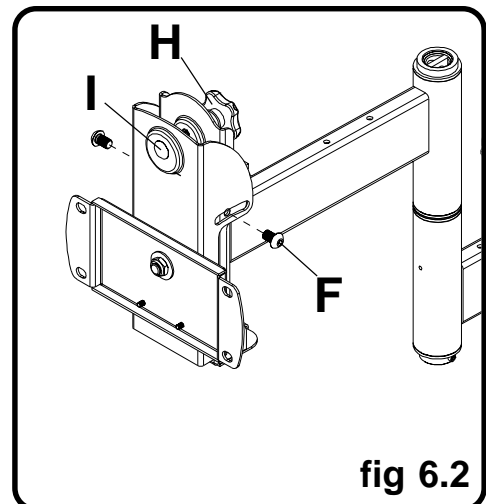

Adapter bracket not shown for clarity.

Installing Adapter Brackets

Refer to **Screen Compatibility Chart** to determine the proper fasteners to use.

- 7** To prevent scratching the screen, set a cloth on a flat, level surface that will support the weight of the screen. Place screen face side down. If screen has knobs on the back, remove them to allow the adapter brackets to be attached. Place adapter brackets (**BB or CC**) on back of screen, align to holes, and center on back of screen as shown in figure 7.1. Attach the adapter brackets to the back of the screen using the appropriate combination of screws, multi-washers, and spacers as shown in figure 7.3.

Note: Top and bottom holes must always be used.

Verify that all holes are properly aligned, and then tighten screws using a phillips screwdriver.

Note: If using security screws, tighten using security allen wrench (**DD**).

⚠ WARNING

- Tighten screws so adapter brackets are firmly attached. Do not tighten with excessive force. Overtightening can cause stress damage to screws, greatly reducing their holding power and possibly causing screw heads to become detached. Tighten to 40 in. • lb (4.5 N.M.) maximum torque.

Notes:

- The number of fasteners used will vary, depending upon the type of screen.
- Multi-washers and spacers may not be used, depending upon the type of screen.
- Use the corresponding hole in the multi-washer that matches your screw size as shown in figure 7.2.

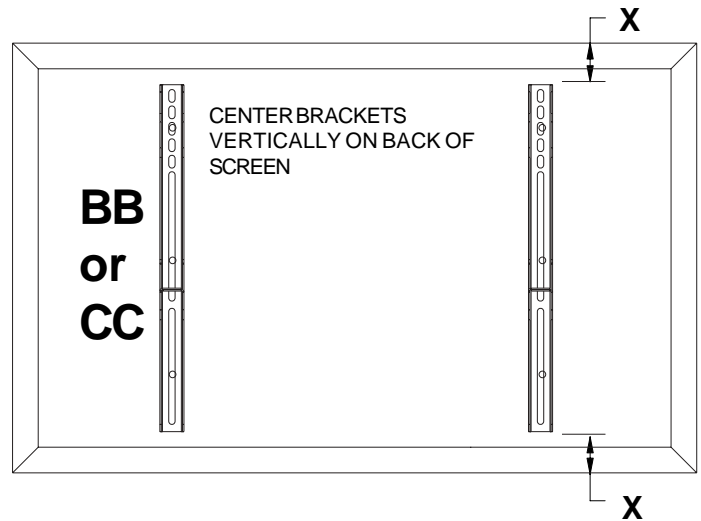
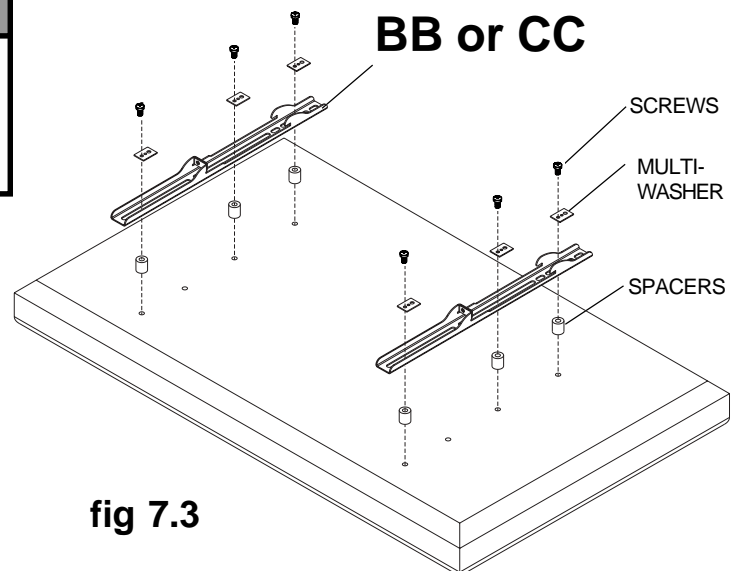
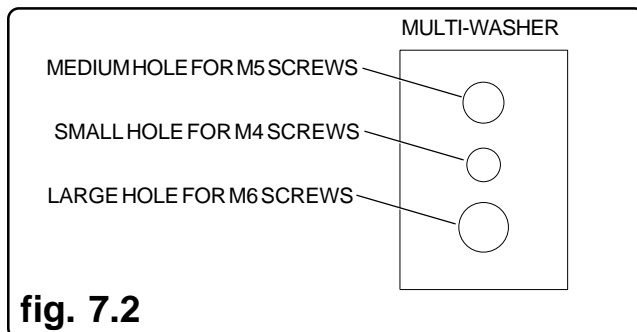

fig 7.1

Note: "X" dimensions should be equal.

⚠ WARNING

- If screws don't get three complete turns in the screen inserts or if screws bottom out and bracket is still not tightly secured, damage may occur to screen or product may fail.



Mounting and Removing Flat Panel Screen

Refer to mount instruction sheet for attachment of adapter bracket to mount.

- 8 Hook adapter brackets (**BB or CC**) onto adapter bracket (**AA**), then slowly swing screen in as shown. Turn screws clockwise at least six times to prevent screen from being removed as shown in detail 4. Tighten using allen wrench (**DD**). Screen can be adjusted horizontally if desired.

Note: To lock the screen down, tighten screws to adapter bracket as shown in detail 4.

To remove screen from mount, loosen screws, swing screen away from mount, and lift screen off of mount.

⚠ WARNING

- Always use an assistant or mechanical lifting equipment to safely lift and position the plasma television.

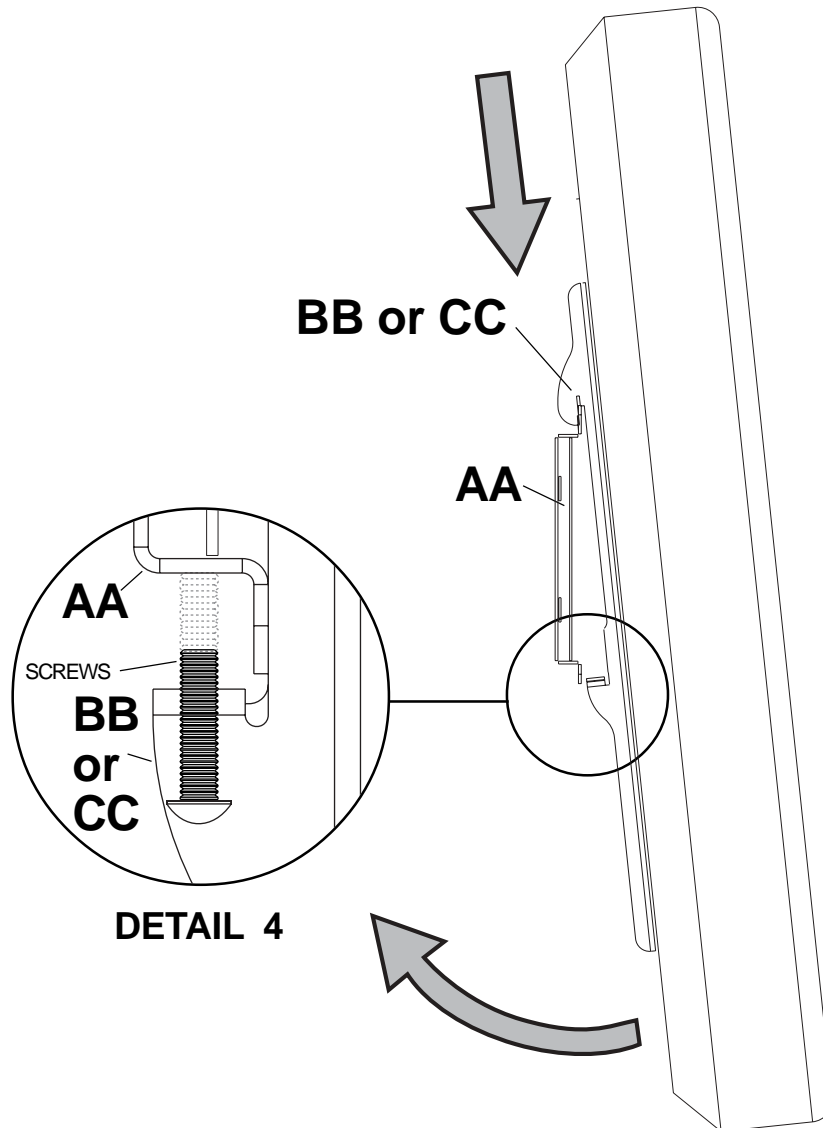

9 Depending on the specific size & weight of the plasma, articulating swing arm may be angled at different positions, causing plasma to appear to lean sideways at different articulating positions. Tilt-roll assembly (B) allows plasma to be manually adjusted, so plasma can be horizontal at all positions. To adjust, gently rotate plasma by hand to desired position.

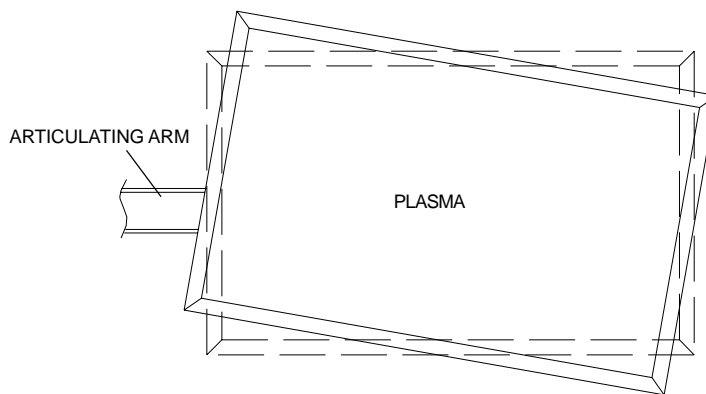

9-1 If it is too difficult to adjust roll of plasma, loosen screws shown in figure 9.1 using a phillips screwdriver.

IMPORTANT! Do not loosen or tighten screws more than 1/8 turn.

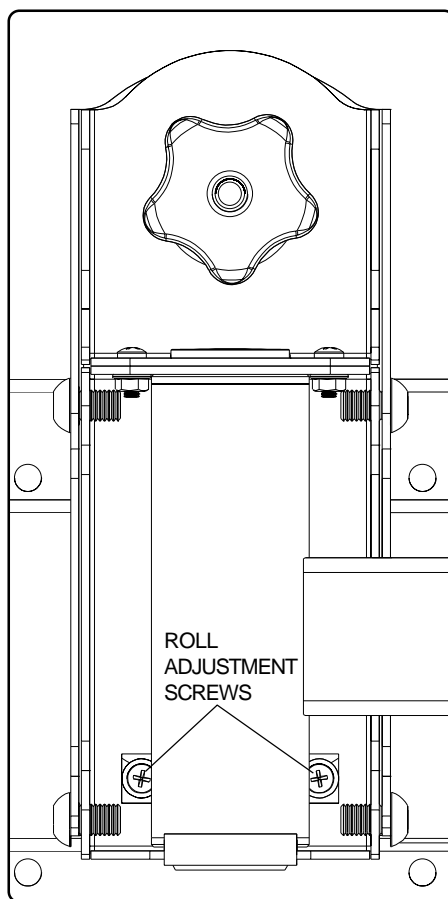

fig 9.1