



RELIABILITY BUILT IN™

Limited One Year Warranty

T&S warrants to the original purchaser (other than for purposes of resale) that such product is free from defects in material and workmanship for a period of one (1) year from the date of purchase. During this one-year warranty period, if the product is found to be defective, T&S shall, at its options, repair and/or replace it. To obtain warranty service, products must be returned to...

*T&S Brass and Bronze Works, Inc.
Attn: Warranty Repair Department
2 Saddleback Cove
Travelers Rest, SC 29690*

Shipping, freight, insurance, and other transportation charges of the product to T&S and the return of repaired or replaced product to the purchaser are the responsibility of the purchaser. Repair and/or replacement shall be made within a reasonable time after receipt by T&S of the returned product. This warranty does not cover items which have received secondary finishing or have been altered or modified after purchase, or for defects caused by physical abuse to or misuse of the product, or shipment of the products.

Any express warranty not provided herein, and any remedy for Breach of Contract which might arise, is hereby excluded and disclaimed. Any implied warranties of merchantability or fitness for a particular purpose are limited to one year in duration. Under no circumstances shall T&S be liable for loss of use or any special consequential costs, expenses or damages.

Some states do not allow limitations on how long and implied warranty lasts or the exclusion or limitation of incidental or consequential damages, so the above limitations or exclusions may not apply to you. Specific rights under this warranty and other rights vary from state to state.

P/N: 098-003148-45 Rev.2
Date: 04-24-98
Drawn: CW
Checked: MVW 06-10-98
Approved: MAB 06-10-98

Installation and Maintenance Instructions



B-1200 Series Push-Back Glass Fillers

Deutsch: Installations- und
Wartungsanleitungen

Español: la Instalación y las
Instrucciones de Man-
tenimiento

Français: les Instructions
d'Installation et
d'Entretien

Exploded View

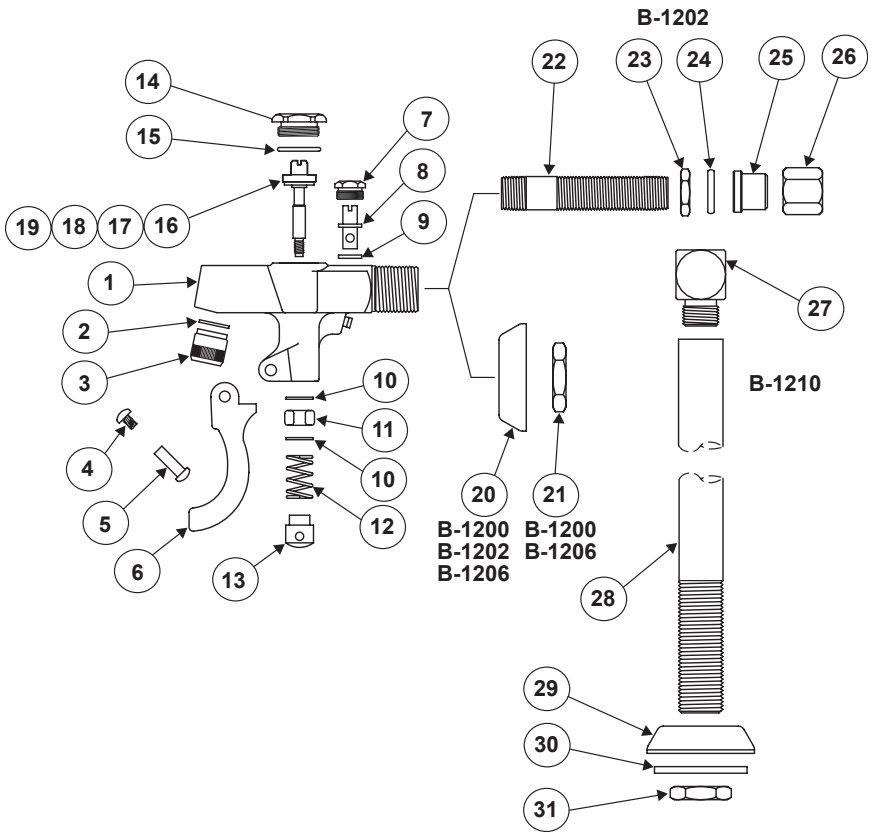

* Some items are listed for instructional purposes and may not be sold as separate parts.

Part Number Guide

Glass Filler Assemblies

	Asm, Glass Filler (B-1200 thru B-1210)	
1	Asm, Body - Glass Filler & Pin	*
2	Washer	001030-45
3	Tip, Glass Filler	003090-45
4	Screw, Handle	003199-45
5	Nut, Handle	003198-45
6	Lever Arm, Blue Lexan	001145-45
7	Nut, Volume Control	000714-25
8	Stem, Volume Control	000834-25
9	Washer, Volume Control	001031-45
10	Washer, Bonnet	000974-45
11	Packing Stem	001100-45
12	Spring	000894-45
13	Pushbutton	000752-25
14	Hexcap	000623-40
15	O-Ring	001062-45
16	Asm, Stem	*
17	Holder, Seat Washer	000664-20
18	Stem	000826-20
19	Washer, Seat	001094-45
20	Flange (B-1200, B-1202, B-1206)	000023-40
21	Locknut (B-1200, B-1206)	000713-20
	<i>(Items 22 thru 26 used on B-1202 model)</i>	
22	Nipple	000379-20
23	Locknut	000716-20
24	Washer	001032-45
25	Tailpiece	000852-20
26	Coupling Nut	000715-20
	<i>(Items 27 thru 27 used on B-1210 model)</i>	
27	Pedestal Cube	*
28	Pedestal - 8"	000425-40
29	Flange	000024-40
30	Washer, Pedestal	001033-45
31	Locknut	002954-45

General Instructions

Installation: (B-1200)

1. Turn off water supply and drain lines. Hand tighten no.20 firmly against no.1 and remove no.21 from no.1.

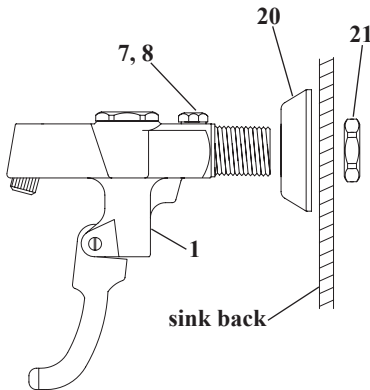

2. Drill 7/8" hole in sheet metal. Insert no.1 through hole and screw no.21 on back of no.1, leaving no.20 free to turn.
3. Apply teflon tape or pipe joint compound to threads of water supply line. Connect no.1 to water supply line outlet, tightening as far as possible.
4. Tighten no.20 and no.21 so they are flush against surface of sink back.
5. Turn on water supply and check for leaks.

Flow Adjustment:

To adjust water flow, loosen no.7 with a wrench, then use screwdriver to turn no.8 to desired setting. Tighten no.7 when flow adjustment is complete.

Installation: (B-1210)

1. Turn off water supply and drain lines.
2. Unscrew and remove no.31 and no.30 from no.28. Position no.29 to cover threads of no.28.
3. Place no.28 through 7/8" hole in countertop. Replace no.30 and no.31 onto no.28 and tighten with a wrench at bottom side of countertop.

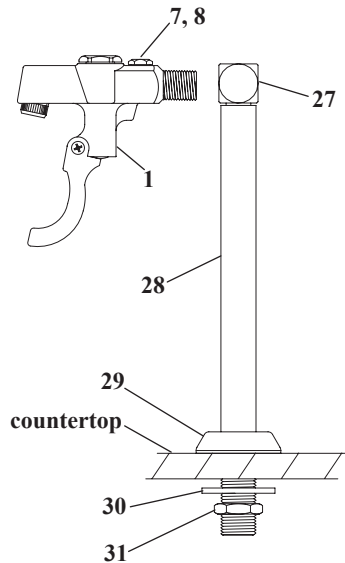

4. Screw no.1 into no.27 and tighten firmly.
5. Apply teflon tape or pipe joint compound to threads of no.28, connect to water supply line inlet.
6. Turn on water supply and check for leaks.

To adjust water flow see flow adjustment note for B-1200 model.

Instrucciones Generales

Instalación: (B-1200)

1. Cierre la fuente principal de agua y desagüe las tuberías. Firmemente aprete a mano la parte No.20 contra la parte No.1 y remueva la parte No.21 de la parte No.1.

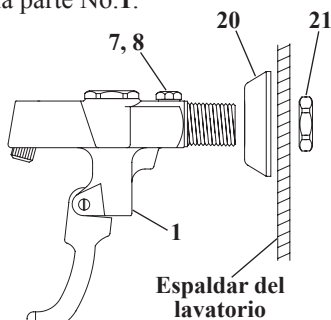

2. Perfore un hueco de 2.5cm en el metal laminado, inserte la parte No.1 a través del hueco y atornille la parte No.21 en la parte posterior de la parte No.1, dejando la parte No.20 suelta para que gire.

3. Aplique cinta para rosca de tubería o compuesto de coyuntura a las roscas de las líneas de surtido. Conecte la parte No.1 a la línea de surtido y aprétela al máximo trayecto.

4. Apriete las partes No.20 y No.21 a medida de que estén a rás contra la parte de atrás del lavatorio.

5. Abra la fuente principal de agua e inspeccione por filtraciones.

Ajuste De Volumen:

Para ajustar el volumen, afloje la parte No.7 con una llave, luego utilice un destornillador para girar la parte No.8 al ajuste deseado. Apriete la parte No.7 cuando haya completado el ajuste del volumen.

Instalación: (B-1210)

1. Cierre la fuente principal de agua y desagüe las tuberías.

2. Destornille y remueva las partes No.31 y No.30 de la parte No.28. Posicione la parte No.29 de modo que cubra las roscas de la parte No.28.

3. Coloque la parte No.28 a través del hueco de 2 cm en el mostrador. Coloque de nuevo las partes No.30 y No.31 en la parte No.28 y apriete con una llave por la parte posterior del mostrador.

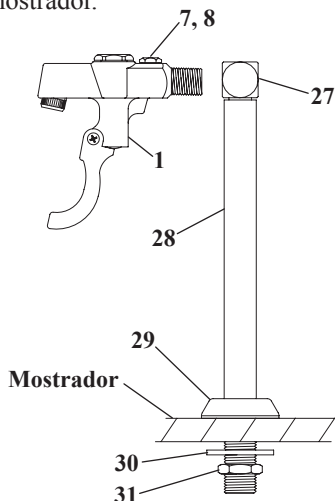

4. Atornille la parte No.1 entre la parte No.27 y apriete firmemente.

5. Aplique cinta para rosca de tubería o compuesto de coyuntura a las roscas de la parte No.28, conecte a las líneas de surtido de agua.

6. Abra la fuente principal de agua e inspeccione por filtraciones.

Para ajustar el volumen, refiérase a la nota en el modelo B-1200 ajuste de volumen.

Instructions Générales

L'Installation: (B-1200)

1. Fermer la réserve de l'eau et égoutter la tuyauterie. Resserrer par main N°20 fermement contre N°1 et enlever N°21 de N°1.

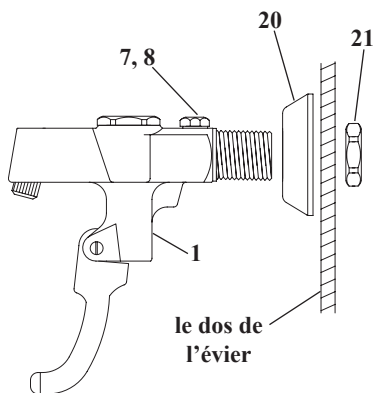

2. Percer un trou de 2cm dans la tôle. Insérer N°1 à travers le trou et visser N°21 sur le dos de N°1, en laissant N°20 libre à tourner.

3. Appliquer le ruban en Téflon ou le composé pour les tuyaux aux filets des tuyaux qui fournir l'eau. Brancher N°1 à la sortie du tuyau qui fournir l'eau.

4. Resserrer N°20 et N°21 pour être au même niveau de la surface du dos de l'évier.

5. Recommencer l'eau et vérifier s'il ya a des fuites.

Le Réglage De La Circulation:

Pour régler la circulation de l'eau, desserrer N°7 avec une clef, puis utiliser un tournevis pour tourner N°8 jusqu'au réglage désiré. Resserrer N°7 quand le réglage de la circulation être complet.

L'Installation: (B-1210)

1. Fermer la réserve de l'eau et égoutter la tuyauterie.

2. Dévisser et enlever N°31 et N°30 de N°28. Placer N°29 pour couvrir les filets de N°28.

3. Mettre N°28 à travers le trou de 2cm dans le comptoir. Remplacer N°30 et N°31 sur N°28 et resserrer avec une clef au fond du comptoir.

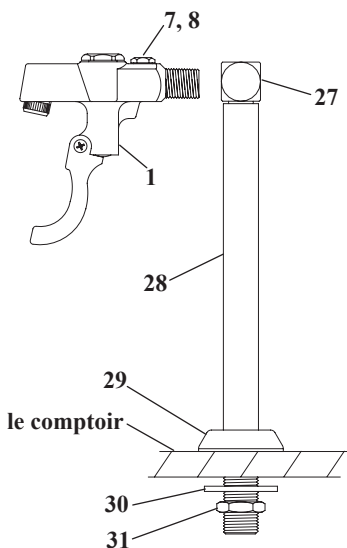

4. Visser N°1 dans dans N°27 et resserrer fermement.

5. Appliquer le ruban en Téflon ou le composé pour les tuyaux aux filets de N°28, brancher à l'arrivée du tuyau qui fournir l'eau.

6. Recommencer l'eau et vérifier s'il ya a des fuites.

Pour régler la circulation de l'eau, voir la note pour le réglage du modèle B-1200.

Allgemeine Anleitungen

Installation: (B-1200)

1. Wasserzufuhr abstellen und Leitungen entleeren. Mit der Hand Nr.20 fest gegen Nr.1 anziehen und Nr.21 von Nr.1 entfernen.

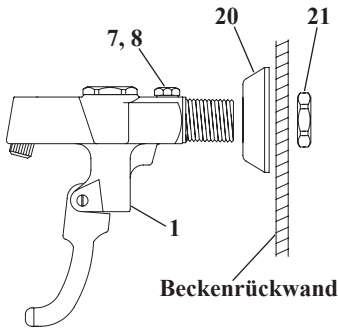

2. Ein 2cm Loch in das Blech bohren. Nr.1 durch das Loch führen und Nr.21 auf die Rückseite von Nr.1 schrauben. Sicherstellen, daß sich Nr.20 drehen läßt.

3. Teflonband oder Rohrdichtmasse auf das Gewinde der Wasserzufuhrleitung auftragen. Nr.1 mit dem Wasserausflußrohr verbinden, so fest wie möglich anziehen.

4. Nr.20 und Nr.21 anziehen, so daß sie glatt gegen die Oberfläche der Beckenrückwand anliegen.

5. Wasserzufuhr andrehen und auf Lecks prüfen.

Flußeinstellung:

Um den Wasserfluß einzustellen, Nr.7 mit einem Schraubenschlüssel losdrehen und dann mit dem Schraubenzieher Nr.8 auf die gewünschte Einstellung drehen. Nach Beendigung der Flußeinstellung Nr.7 anziehen.

Installation: (B-1210)

1. Wasserzufuhr abstellen und Leitungen entleeren.

2. Nr.31 und Nr.30 von Nr.28 losschrauben und entfernen. Nr.29 so ausrichten, daß das Gewinde von 28 bedeckt wird.

3. Nr.28 durch das 2cm große Loch in der Abdeckplatte stecken. Nr.30 und Nr.31 wieder auf 28 aufsetzen und mit einem Schraubenschlüssel auf der Unterseite der Abdeckplatte festziehen.

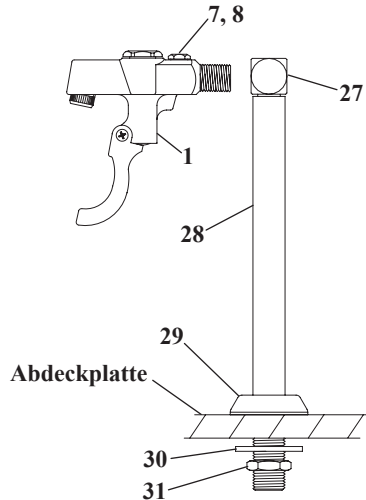

4. Nr.1 in Nr.27 schrauben und fest anziehen.

5. Teflonband oder Rohrdichtmasse auf das Gewinde von 28 auftragen, mit dem Wasserzufuhrrohr verbinden.

6. Wasserzufuhr andrehen und auf Lecks prüfen.

Zur Einstellung des Wasserflusses wird auf die Anmerkung zum Wasserfluß für das Modell B-1200 verwiesen.

RELATED T&S BRASS PRODUCT LINE



**B-1225
Combination Glass
Pitcher Filler**



**B-1230
Water Station**

T&S BRASS AND BRONZE WORKS, INC.

A firm commitment to application-engineered plumbing products

2 Saddleback Cove, P.O. Box 1088,
Travelers Rest, SC 29690

Phone: (864) 834-4102

Fax: (864) 834-3518

E-mail: tsbrass@tsbrass.com

T & S Brass-Europe

'De Veenhoeve'

Oude Nieuwveenseweg 84

2441 CW Nieuwveen

The Netherlands



RELIABILITY BUILT IN™