



Limited One Year Warranty
T&S warrants to the original purchaser (other than for purposes of resale) that such product is free from defects in material and workmanship for a period of one (1) year from the date of purchase. During this one-year warranty period, if the product is found to be defective, T&S shall, at its options, repair and/or replace it. To obtain warranty service, products must be returned to...

T&S Brass and Bronze Works, Inc.
Attn: Warranty Repair Department
2 Saddleback Cove
Travelers Rest, SC 29690

Shipping, freight, insurance, and other transportation charges of the product to T&S and the return of repaired or replaced product to the purchaser are the responsibility of the purchaser. Repair and/or replacement shall be made within a reasonable time after receipt by T&S of the returned product. This warranty does not cover items which have received secondary finishing or have been altered or modified after purchase, or for defects caused by physical abuse to or misuse of the product, or shipment of the products.

Any express warranty not provided herein, and any remedy for Breach of Contract which might arise, is hereby excluded and disclaimed. Any implied warranties of merchantability or fitness for a particular purpose are limited to one year in duration. Under no circumstances shall T&S be liable for loss of use or any special consequential costs, expenses or damages.

Some states do not allow limitations on how long and implied warranty lasts or the exclusion or limitation of incidental or consequential damages, so the above limitations or exclusions may not apply to you. Specific rights under this warranty and other rights vary from state to state.

P/N: 098-011395-45
Date: 980109
Drawn: CW
Checked: JLT 4-14-98
Approved: MW 4-14-98

Installation and Maintenance Instructions

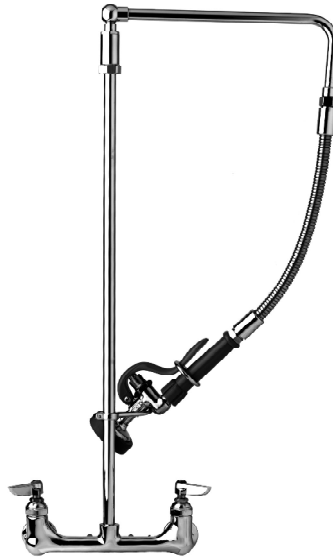

PRE-RINSE UNIT
B-0131 (Also for B-0111, B-0121,
B-0141, B-0171)

**Deutsch: Installations- und
Wartungsanleitungen**

**Español: la Instalación y las
Instrucciones de
Mantenimiento**

**Français: les Instructions
d'Installation et
d'Entretien**

Exploded View

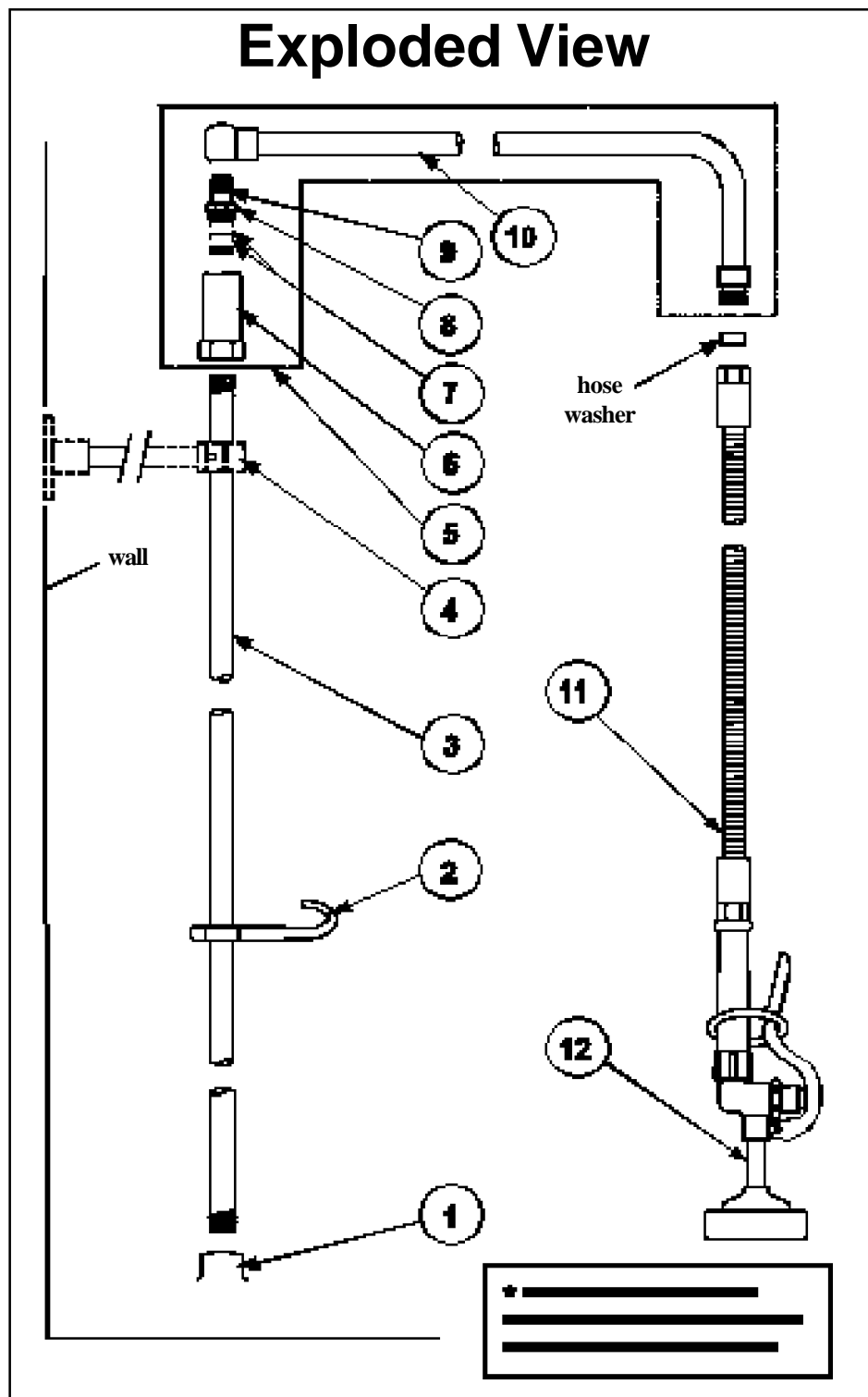

Part Number Guide

Pre-Rinse Assemblies

1	Asm, Base Faucet	
	B-0111	002824-40
	B-0121	002829-40
	B-0131	002832-40
	B-0141	B-0430 & B-0512
	B-0171	002827-40
2	Asm, Finger Hook w/ screw	002873-40
3	Nipple	
	3/8"x26" (For B-0131 Only)	000373-40
	3/8"x32 (For other Models)	000376-40
4	Wall Bracket (optional - not incl.)	B-0109-01
5	Asm, "L" Tube 12"	002882-40
6	Body, Swivel Unit 3/8	000591-25
7	O'-Ring	001074-45
8	Nut, Hex Swivel	000735-40
9	Stem, Swivel	000839-25
10	"L" Tube 12"	000384-40
11	Asm, SS Flex Hose	B-0020-H
12	Asm, Spray Valve	B-0107

General Instructions

Installation: Riser & Hose Assembly

See separate instructions for installing no.1 into deck.

1. Shut off water supply and drain lines.
2. Apply teflon tape or pipe joint compound on both ends of no.3.
3. Screw no.3 firmly into no.1 by hand.
4. Slide no.2 down no.3 (about halfway) and tighten temporarily.
5. Screw no.6 firmly onto no.3, and firmly tighten no.6 with a wrench.

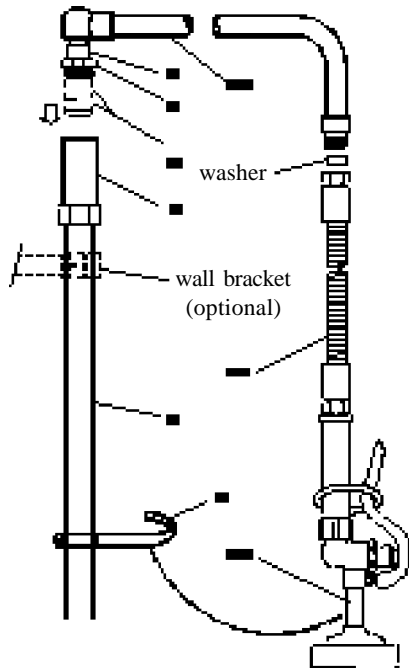
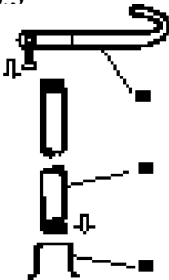

6. Remove no.8 and no.9 from no.6. Apply teflon tape or pipe joint compound to threaded end of no.8.

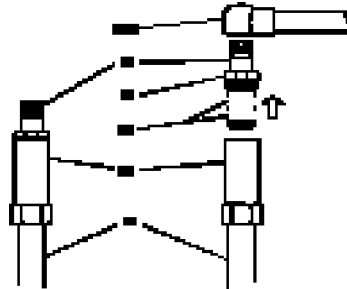

7. Screw threaded end of no.9 into ball end of no.10.
8. Apply a coat of grease to no.7 (if replacing). Install and tighten no.8 and no.9 into no.6.

Note: Also use step 6 and 8 of this procedure for replacement of worn or damaged no.7.

9. Attach end of no.11 to no.10. (Make sure hose washer is in place). No.12 should rest in a comfortable position on no.2 when completely assembled.
10. Turn on water and check for leaks.

Optional Wall Bracket

Note: T&S Brass highly recommends installing a B-0109-01 Wall Bracket to no.3 with these Pre-Rinse Units for a more secure installation. Fit as high as possible on no.3. Cut off any excess nipple (unthreaded end) as needed, and mount to wall.

Instrucciones Generales

Instalación: Extensión & Ensamble de manguera

Mire las instrucciones para la instalación de la parte No.1 dentro del mostrador.

1. Cierre la fuente principal de agua y desagüe las tuberías.

2. Aplique cinta para roscas de tubería o compuesto de coyuntura a los dos extremos de las partes No.3.

3. A mano atornille la parte No.3 firmemente entre la parte No.1.

4. Deslice la parte No.2 sobre la parte No.3 (aproximadamente medio trayecto) y temporariamente apretélo.

5. Atornille la parte No.6 firmemente en la parte No.3 y aprete firmemente la parte No.6 con una llave.

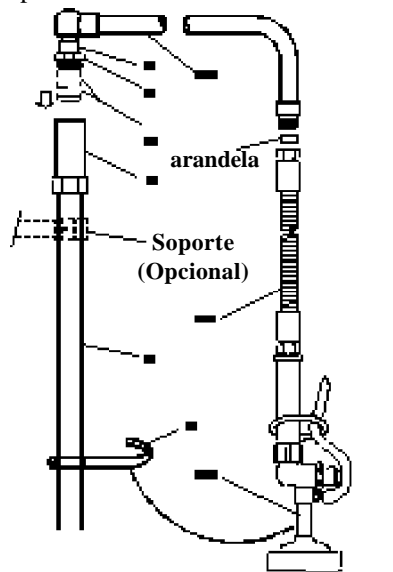

6. Remueva las partes No.8 y No.9 de la parte No.6. Aplique cinta para rosca de tubería o compuesto de coyuntura al extremo con rosca de la parte.

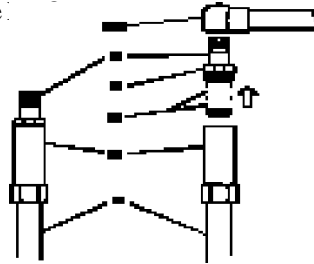

7. Atornille el extremo con rosca de la parte No.9 en el extremo esférico de la parte No.10.

8. Aplique una capa de grasa a la parte No.7 (si la esta reemplazando). Instale y aprete las parte No.8 y No.9 en la parte No.6.

Nota: Tambien use el paso No.6 y 8 de este procedimiento para el reemplazo de la parte No.7 si esta gastada o dañada.

9. Empate el extremo de la parte No.11 a la No.10. (Asegúrese que la arandela de la manguera este bien situada). La parte No.12 debe de terminar en una posición cómoda en la parte No.2 cuando este completamente ensamblado.

10. Abra la fuente de agua e inspeccione por filtraciones.

Soporte Opcional Con Montadura Para La Pared

Nota: Es altamente recomendado por T&S que se instale el soporte B-0109-01 a la parte No.3 con estas unidades de jugadora para una instalación mas segura. Acomode el soporte en la parte No.3 lo más alto posible. A medida necesitada corte el exceso de tubo (extremidad sin rosca) y encajelo a la pared.

Instructions Générales

L'Installation: L'Assemblée D'Augmentation Et Du Tuyau

Voir les instructions séparées pour installer N°.1 dans l'égouttoir.

1. Fermer la réserve de l'eau et égoutter la tuyauterie.
2. Appliquer le ruban en Téflon ou le composé pour les tuyaux à chaque extrémité de N°.3.
3. Visser N°.3 fermement dans N°.1 par le main.
4. Faire glisser N°.2 environ mi-chemin N°.3 et resserrer temporairement.
5. Visser N°.6 fermement sur N°.3 et resserrer fermement N°.6 avec une clef.

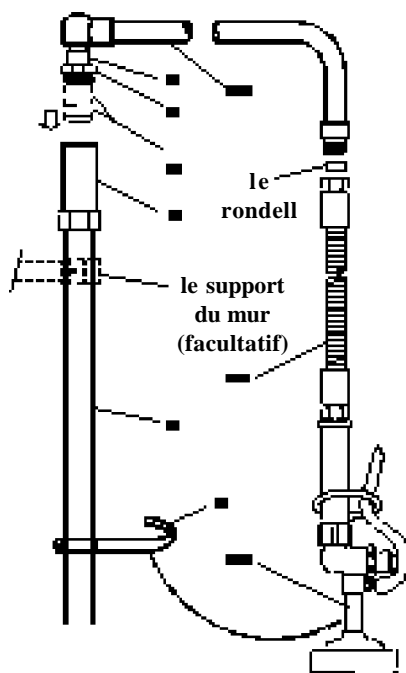
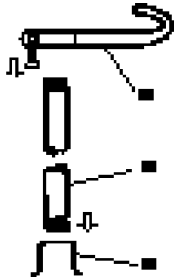

6. Enlever N°.8 et N°.9 de N°.6.
Appliquer le ruban en Téflon ou le composé pour les tuyaux à l'extrémité de N°.8 avec les filets.

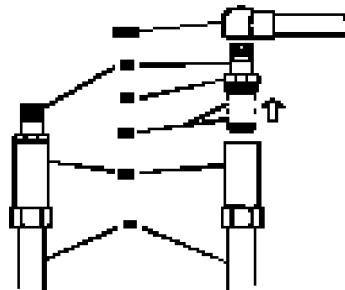

7. Visser l'extrémité de N°.9 avec les filets dans l'extrémité avec le bal de N°.10.
8. Appliquer une couche de la graisse à N°.7 (si vous le remplacer). Installer et resserrer N°.8 et N°.9 dans N°.6.

Noter: Aussi utiliser les étapes 6 et 8 de ce processus pour remplacer N°.7 usé ou dommagé.

9. Attacher l'extrémité de N°.11 à N°.10. (Soyez certain que la rondelle se situer bien). N°.12 devoir s'appuyer sur N°.2 dans une position confortable a la fin de l'assemblage.
10. Recommencer l'eau et vérifier s'il y a des fuites.

Le Support du Mur Facultatif

Noter: T&S vous conseiller l'installation d'un B-0109-01 support du mur à N°.3 avec ces éléments pré-rinçages. Cela va être meilleur pour l'attchement au mur. Mettre le support sur N°.3 le plus haut que possible. Couper l'excès de tuyau comme nécessaire (l'extrémité sans les filets) et monter au mur.

Allgemeine Anleitungen

Installation:

Zusammensetzung von Steigleitung und Schlauch

Teil 1 gemäß Anleitungen auf die Abdeckplatte montieren.

1. Wasser absperren und Wasserleitungen entleeren.
2. Teflonband oder Rohrkitt auf beide Enden von 3 auftragen.
3. Nr.3 fest mit der Hand in Nr.1 einschrauben.

4. Nr.2 in Nr.3 hineinschieben (ungefähr halbwegs) und vorübergehend festdrehen.

5. Nr.6 fest auf Nr.3 aufschrauben und Nr.6 mit Schraubenschlüssel festdrehen.

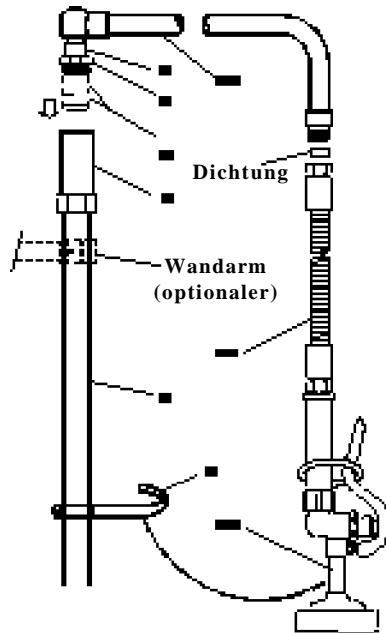
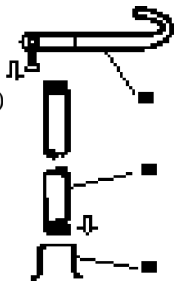

6. Nr.8 und Nr.9 von 6 entfernen. Teflonband oder Rohrkitt auf Gewinde von Nr.8 schmieren.

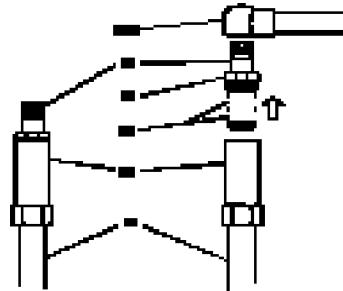

7. Gewindeende von Nr.9 in Kugelende von Nr.10 schrauben.

8. Schmirgelpapier auf 7 auftragen (falls Ersatz erfolgt). Nr.8 und Nr.9 in 6 installieren und festdrehen.

Anmerkung: Schritt 6 und 8 dieses Verfahrens auch anwenden, wenn abgenutztes oder beschädigtes Teil 7 ersetzt wird.

9. Ende von Nr.11 auf Nr.10 befestigen (sicherstellen, daß Schlauchdichtung am richtigen Platz ist). Nr.12 muß bequem auf Nr.2 sitzen, wenn die Zusammensetzung fertig ist.

10. Wasser andrehen und auf Lecks prüfen.

Optionaler Wandarm

Anmerkung: T&S empfiehlt, auf Nr.3 dieser Vorspülgeräte einen B-0109-01 Wandarm anzubringen zur sichereren installation. So hoch wie möglich auf Nr.3 anbringen. Überflüssigen Nippel (gewindefreies Ende) nach Bedarf abschneiden und an der Wand anbringen

RELATED T&S BRASS PRODUCT LINE



**B-0137
PRE-RINSE
UNIT**

T&S BRASS AND BRONZE WORKS, INC.

A firm commitment to application-engineered plumbing products

2 Saddleback Cove, P.O. Box 1088,
Travelers Rest, SC 29690

Phone: (864) 834-4102
Fax: (864) 834-3518

E-mail: tsbrass@tsbrass.com

T & S Brass-Europe
'De Veenhoeve'
Oude Nieuwveenseweg 84
2441 CW Nieuwveen
The Netherlands

