

# SPECI 56703

lineabeta®

SPECCHIO DISAPPANNANTE, CON LUCE LED INTEGRATA, ACCENSIONE E  
SPEGNIMENTO CON TOUCH SCREEN  
WALL MIRROR WITH BUILT IN LED LIGHT, DEMISTER AND TOUCH SCREEN  
CONTROL

WEIGHT kg 13,39  
VOLUME m<sup>3</sup> 0,0598

12W 230V IP44 CE □ 5 YEARS SILVERING GUARANTEED

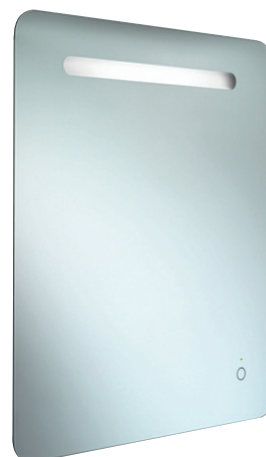

## MAINTENANCE

Pulire con panno morbido inumidito. Non usare ammoniaca, detersivi, abrasivi contenenti candeggina

Clean with warm soapy water. Never use ammonia, abrasives, bleach or solvent based cleaners.

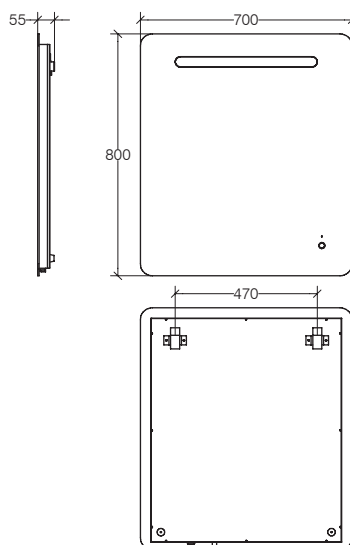

Lineabeta SpA®  
Strada Statale 11, Km 331  
36053 Gambellara VI (Italy)  
Tel +39 0444 644644  
Fax +39 0444 644600  
info@lineabeta.com  
www.lineabeta.com

LINEABETA SPA si riserva in esclusiva i diritti di modificare le dimensioni, caratteristiche tecniche, design dei suoi prodotti, senza preavviso. Tutte le dimensioni sono indicative e potrebbero variare in conformita degli standard europei.  
LINEABETA SPA reserves the exclusive right to modify dimensions, technical characteristics and aesthetic design of its productys, without prior notification. all dimensions are indicative and may vary to conform to european standards.

