

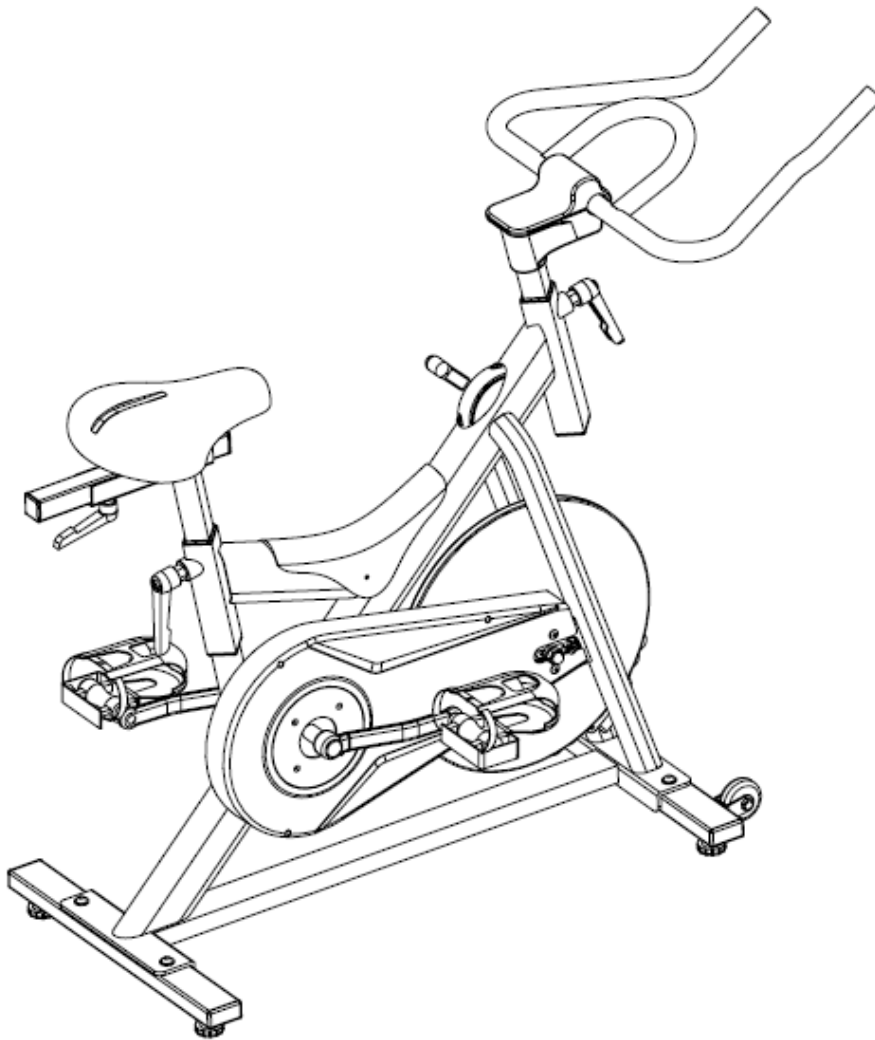

MAGNETIC INDOOR CYCLING BIKE

SF-B904



The specifications of this product may vary from this photo and are subject to change without notice.

For Customer Service, please contact: support@sunnyhealthfitness.com

Important Safety Information

We thank you for choosing our product. To ensure your safety and health, please use this equipment correctly. Please read the information below carefully before using this equipment. It is important to read this entire manual before assembling and using the equipment. Safe and effective use can only be achieved if the equipment is assembled, maintained and used properly.

1. Before starting any exercise program you should consult your doctor to determine if you have any medical or physical conditions that could put your health and safety at risk, or prevent you from using the equipment properly.
2. Your doctor's advice is essential if you are taking medication that affects your heart rate, blood pressure or cholesterol level.
3. Be aware of your body's signals. Incorrect or excessive exercise can damage your health. Stop exercising if you experience any of the following symptoms: pain, tightness in your chest, irregular heartbeat, extreme shortness of breath, lightheadedness, dizziness or feelings of nausea. If you do experience any of these conditions, you should consult your doctor before continuing with your exercise program.
4. Keep children and pets away from the equipment. The equipment is designed for adult use only.
5. Use the equipment on a solid, flat, level surface with a protective cover for your floor or carpet to ensure safety, the equipment should have at least 0.5 meters of free space all around it.
6. Before using the equipment, please make sure all the nuts and bolts are securely tightened.
7. Always use the equipment as indicated. If you find any defective components while assembling or checking the equipment, or if you hear any unusual noises coming from the equipment during use, stop immediately. Do not use the equipment until the problem has been rectified.
8. Wear suitable clothing while using the equipment. Avoid wearing loose clothing that may get caught in the equipment or that may restrict or prevent movement.
9. This equipment is designed for indoor and home use only, not intended for commercial use. The maximum weight of user: 220LBS.
10. Care must be taken when lifting or moving the equipment so as not to injure your back.
11. The equipment is not suitable for therapeutic use.
12. Please keep this manual and the assembling tools well for future reference.

EXPLODED DIAGRAM

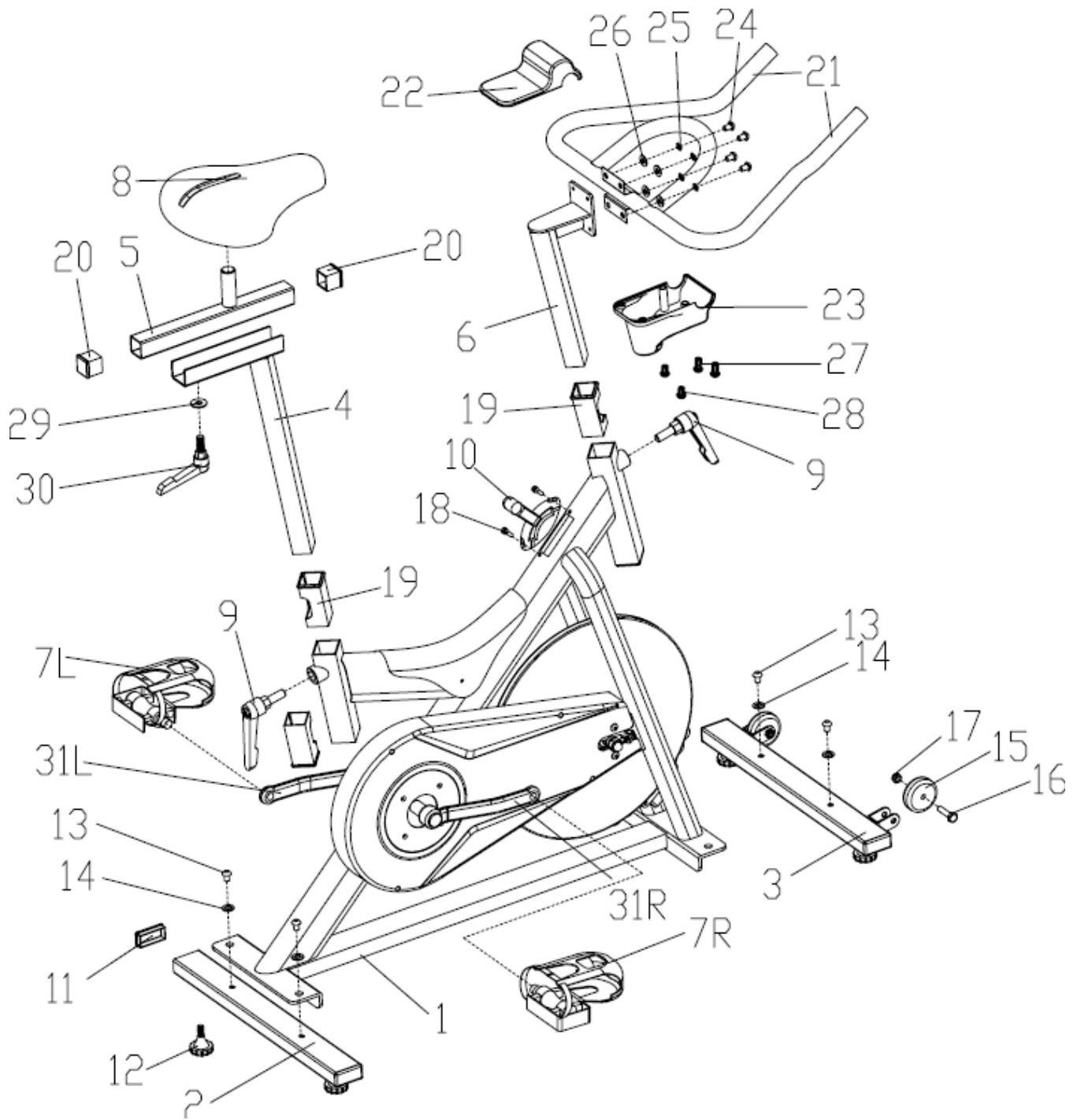

PARTS LIST

Part No.	Description	Qty	Part No.	Description	Qty
1	Main frame	1	17	Nylon nut	2
2	Rear bottom tube	1	18	Screw	2
3	Front bottom tube	1	19	Bushing	4
4	Saddle vertical tube	1	20	Square cap	2
5	Saddle horizontal tube	1	21	Handlebar	1
6	Handlebar post	1	22	Handlebar cover	1
7L/R	Pedal	1pr	23	Handlebar cover	1
8	Saddle	1	24	Allen bolt	4
9	L-shaped knob	2	25	Spring washer	4
10	Resistant brake	1	26	Flat washer	4
11	Square cap	4	27	Phillips screw	2
12	Foot adjustable knob	4	28	Phillips screw	2
13	Allen bolt	4	29	Flat washer	1
14	Flat washer	4	30	Small L-shaped knob	1
15	Transport wheel	2	31L/R	Crank	2
16	Bolt	2			

NOTE:

Most of the listed assembly hardware has been packaged separately, but some hardware items have been preinstalled in the identified assembly parts. In these instances, simply remove and reinstall the hardware as assembly is required.

Please reference the individual assembly steps and make note of all preinstalled hardware.

ASSEMBLY INSTRUCTIONS

Step one:

Install the Front bottom tube (3) and Rear bottom tube (2) to the Main frame (1) with the Bolts (13) and Flat washers (14).

Note: The Foot adjustable knobs (12) under the bottom tubes can be adjusted to keep the equipment stable.

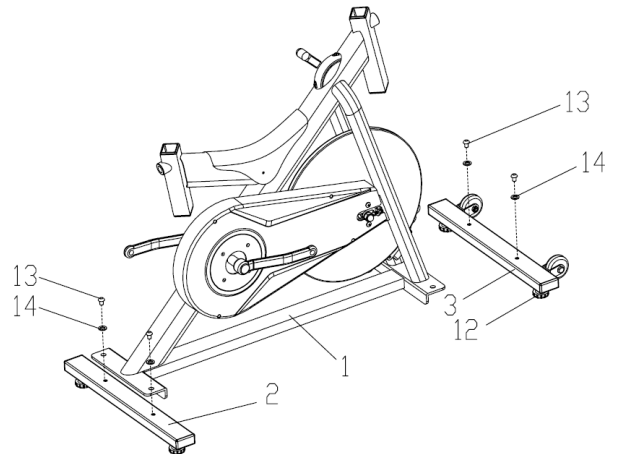

Step two:

Attach the Pedals (7L/R) to the Cranks (31L/R) respectively, viewed from the rider's seated position.

Note: Both pedals are labeled L FOR LEFT and R FOR RIGHT.

Important:

To tighten turn the left pedal COUNTERCLOCKWISE and the right pedal CLOCKWISE.

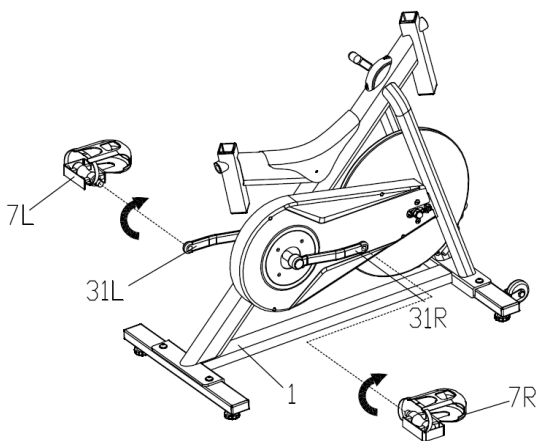

Step three:

Fix the Saddle (8) onto the Saddle horizontal tube (5), and tighten with the multi-functional wrench. Attach the well installed Saddle horizontal tube (5) to the Saddle vertical tube (4), secure with the Flat washer (29) and small L-shaped knob (30). Insert the Saddle vertical tube (4) to the main frame section, secure with the L-shaped knob (9) at a suitable height.

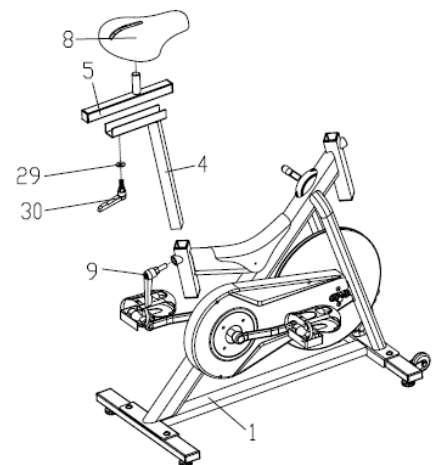

Step four:

Attach the Handlebar (21) to the Handlebar post (6), secured with Bolts (24), Flat washers (26) and Spring washers (25). Then, Set the lower Handlebar cover (23) on the square tube of the Handlebar post (6) in alignment with the four grooves on the mouth of the lower Handlebar cover (23). When the lower Handlebar cover (23) slides to the top of the square tube of the Handlebar post (6); rotate the cover 45 degrees to align with the Handlebar (21). Use Screws (27) (28) to fix the upper Handlebar cover (22) to the lower Handlebar cover (23), so that the Handlebar (21) and Handlebar post (6) are in between the Handlebar cover pieces (22, 23). Finally, turn and loosen the L-shaped knob (9), pull the pin, and then insert the Handlebar (21) assembly into the Main frame (1) section simultaneously. Make sure the pin settles into the desired hole and then secure the Knob.

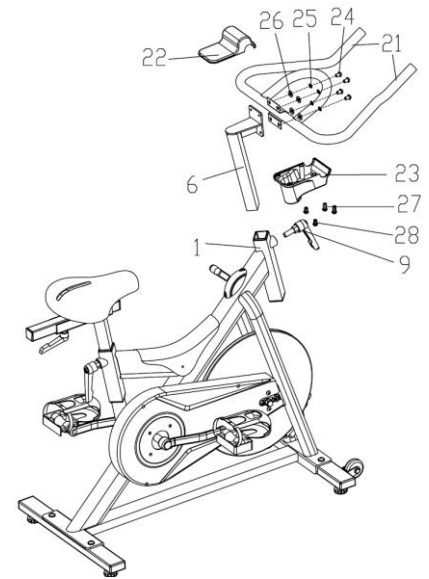

Important:

This machine has equipped with L-shaped knob (9) for saddle & handlebar vertical adjustment. Loosen the knob a little bit (no need to screw it out), and then pull the knob to adjust the height.

- 1. If the L shape knob touches the tube when securing clockwise, please pull down the L shape knob and turn it counterclockwise, then release it and secure it clockwise. Repeat it several times until you secure it firmly.*
- 2. If the L shape knob touches the tube when releasing counterclockwise, please pull down the L shape knob and turn it clockwise, then release it and secure it counterclockwise. Repeat it several times until you can move the handles to desired position.*