

# S207

## ASSEMBLY INSTRUCTIONS CONSIGNES D'ASSEMBLAGE

Assembly tools required : Hammre, Phillips # 3 and Standard screwdriver  
Outils requis pour l'assemblage : Marteau, Trounevis Phillips # 3 et Plat

### Special Notes

To make the assembly simple and well done, you have to be familiar with the parts. Follow the step-by-step instructions on a clean area ( ex. carpet). Read the instructions before starting the assembly

### Remarques Particulière

Pour faciliter l'assemblage de votre meuble, examinez les pièces et la quincaillerie de votre meuble attentivement. Suivre les instructions étape par étape sur une surface propre ( ex. Tapis) Lire soigneusement les consignes avant de procéder à l'assemblage

- 1 - Left Bed side, Côté de lit gauche
- 2 - Upper and lower bed rail, Traverse de lit
- 3 - External doors, Portes extérieur
- 4 - Central door, Porte central
- 5 - Cabinet side left, Côté de cabinet gauche
- 6 - Cabinet top, Cabinet dessus
- 7 - Cabinet Upper rails, Traverse du haut du cabinet
- 8 - Cabinet bottom rails, Traverse du bas du cabinet
- 12 - Bed frame, Cadre du lit
- 13 - Bed wide bottom panel, Panneaux de fond large
- 14 - Bed small bottom panel, Panneau étroit de fond

### Not showing parts :

- 9 - Bed side rail, Traverse de côté du lit
- 10 - Crossing rail, Support transversal
- 11 - Upper and lower rail, Traverse du haut et bas

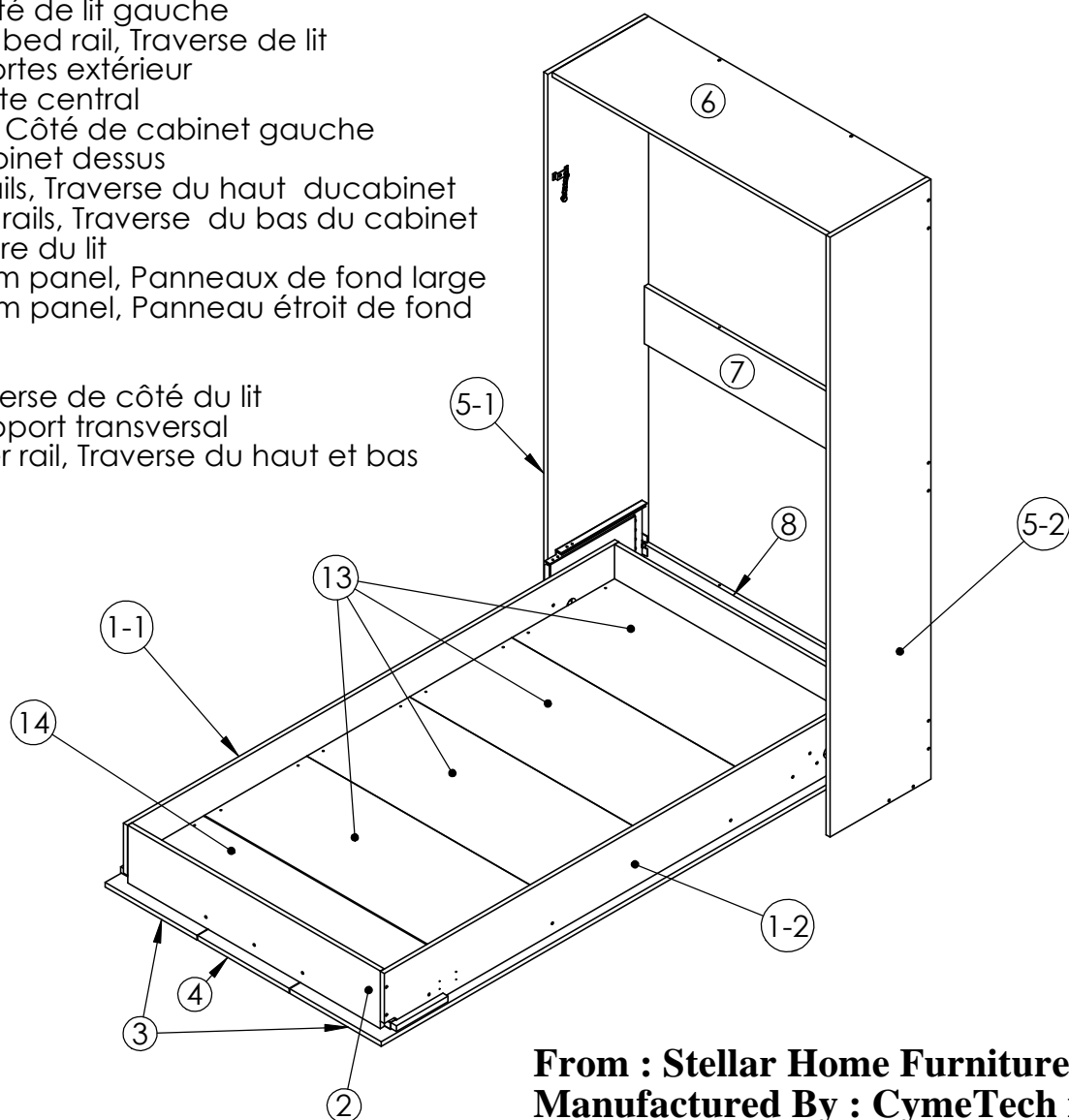

**From : Stellar Home Furniture**  
**Manufactured By : CymeTech inc.**  
**service@stellarhomefurniture.com**

# S207

## Pre-Assembly check list Hardware pack Liste de contrôle de la quincaillerie avant l'assemblage

### Item 15

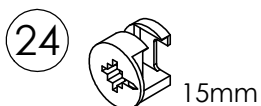

Eccentric housing  
Boitier excentrique

### Item 16

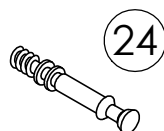

Quick-Fit dowels  
Douilles "quick-Fit"

### Item 17

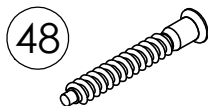

Assembly Screw  
Vis D'assemblage

### Item 18

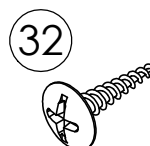

Screw #8 - 1 1/4"  
Vis #8 - 1 1/4"

### Item 19

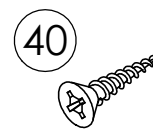

Screw #6 - 5/8"  
Vis #6 - 5/8"

### Item 20



Handle  
Poignée

### Item 21

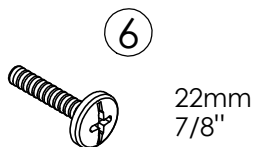

Screw ( round head )  
Vis ( tête ronde )

### Item 22

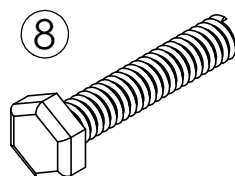

Bolt M6 - 19 mm  
Boulon M6 - 19 mm

### Item 24

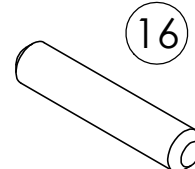

Dowel  
Goujon

### Item 25

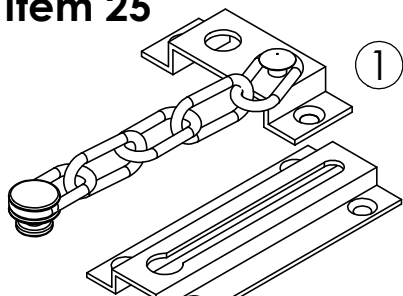

Safety device  
chainette de sécurité

### Item 26

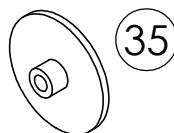

Cache vis  
Screw cap

### Item 27

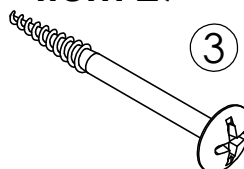

Screw #8 - 2.0 "  
Vis #8 - 2.0 "

### Item 28

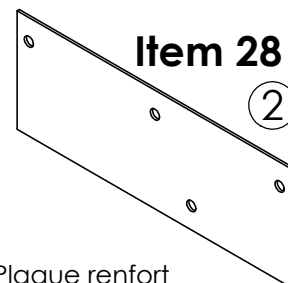

Plaque renfort  
Reinforcement plate

Mécanisme pour lit escamotable  
Partie Gauche montré  
Metal for Collapsible bed  
Left side shown

### Item 30

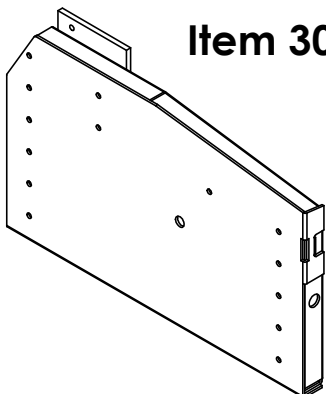

### Item 29

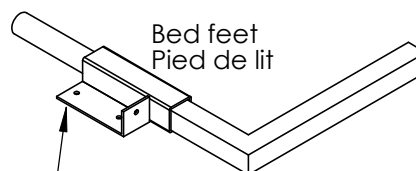

Bed feet  
Pied de lit

Cette itème a un gaughe et un droit  
This item as a left an a right parts

# S207

**Step 1 :**  
Côté Gauche montré  
Left side shown

**Step 2 :**  
Répéter étape 1 côté droit  
sans la chaîne de sécurité  
Repeat step 1 right side  
but seaffy chain

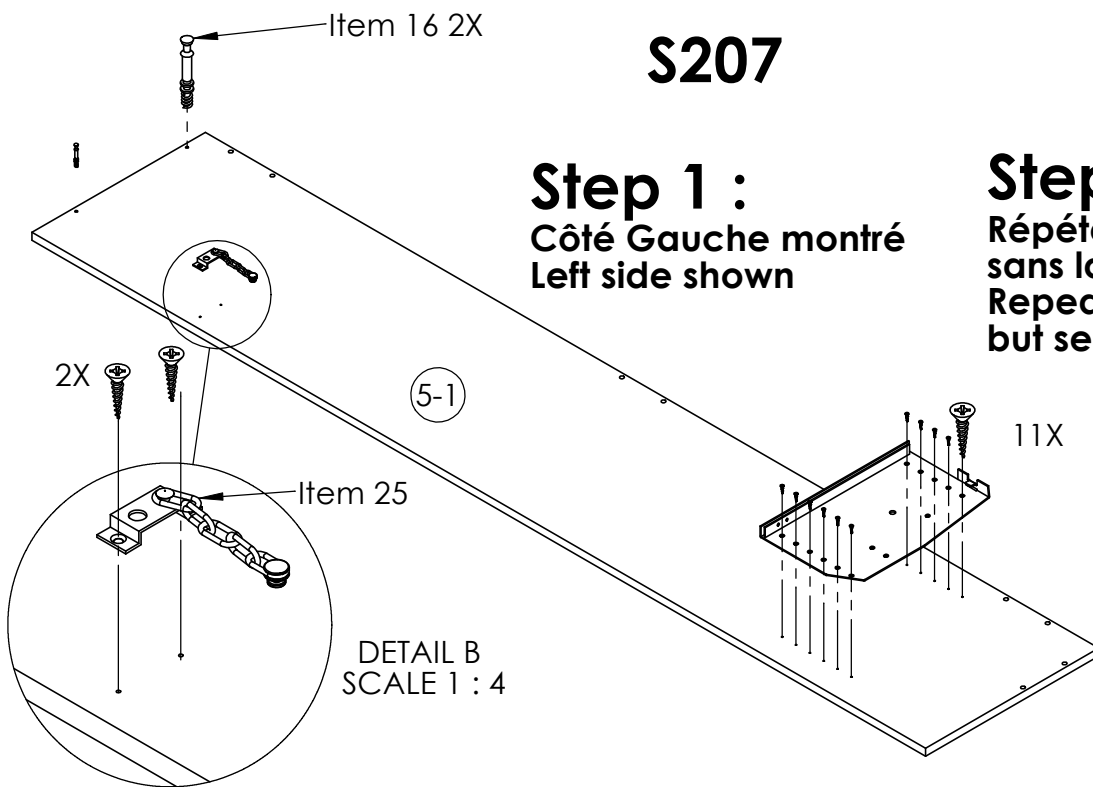

## Step 3

Mettre 2 vis d'assemblage  
sur le dessus, sans cache vis.  
secure two assembly screws  
on the top no screw cap.

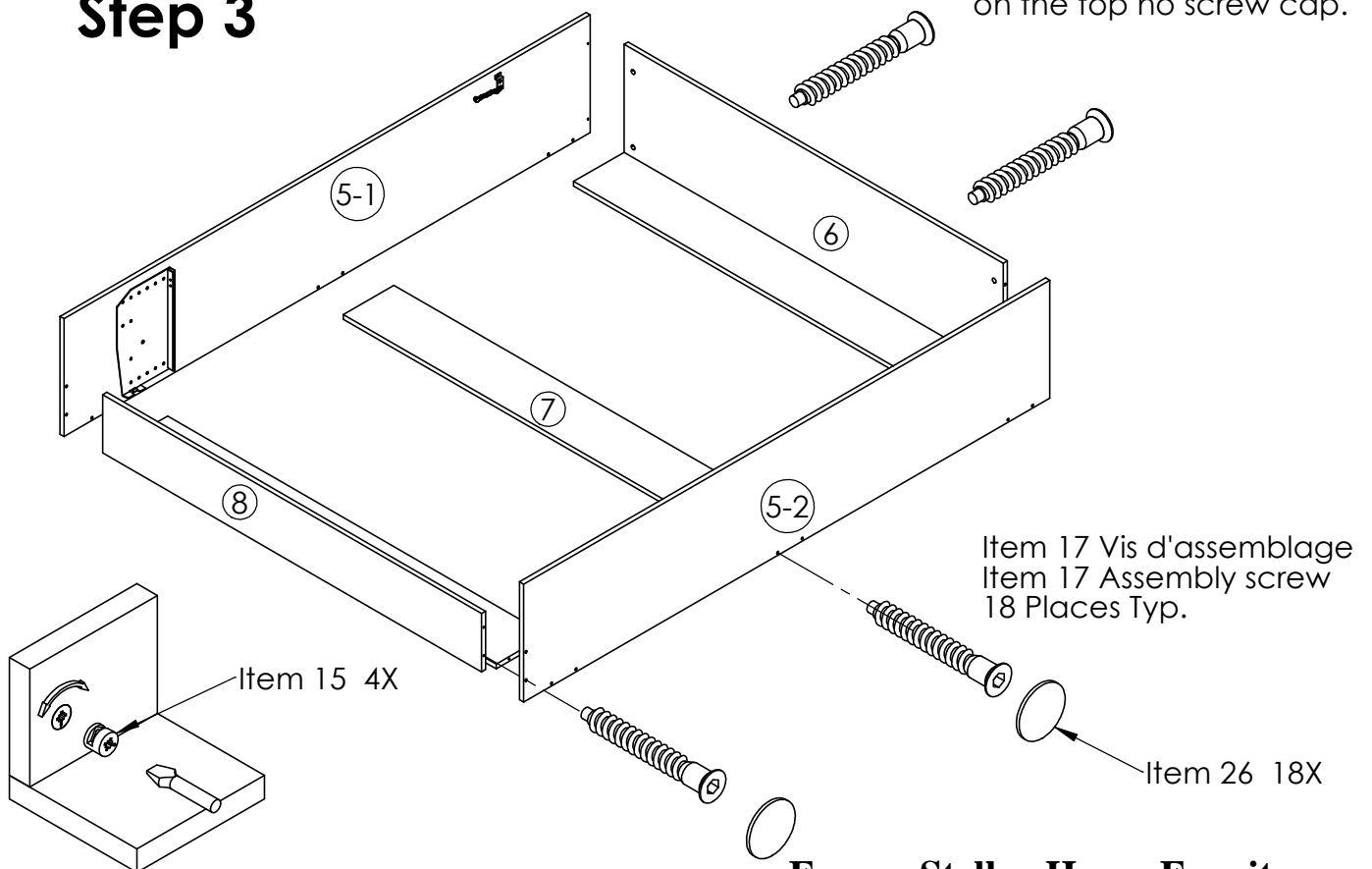

**From : Stellar Home Furniture**  
**Manufactured By : CymeTech inc.**  
[service@stellarhomefurniture.com](mailto:service@stellarhomefurniture.com)

# S 207

Localiser les montant vertical dans le mur, fixer le caisson en utilisant au minimum 2 vis #8 X 2.0" dans la Traverse du haut ( 3 vis incluse).  
Locate vertical stud in the wall, secure the cabinet with a minimum of 2 #8 X 2.0" screws in upper trim ( 3 screws included).

## Step 4

Mettre le niveau sur le cote du caisson et ajuster au besoin.  
Place the cabinet side level and adjust if needed.

Item 27 2X

Ajouter une vis dans la traverse du bas au besoin pour tenir le cabinet de niveau.  
Secure a screw on bottom trim to hold cabinet level.

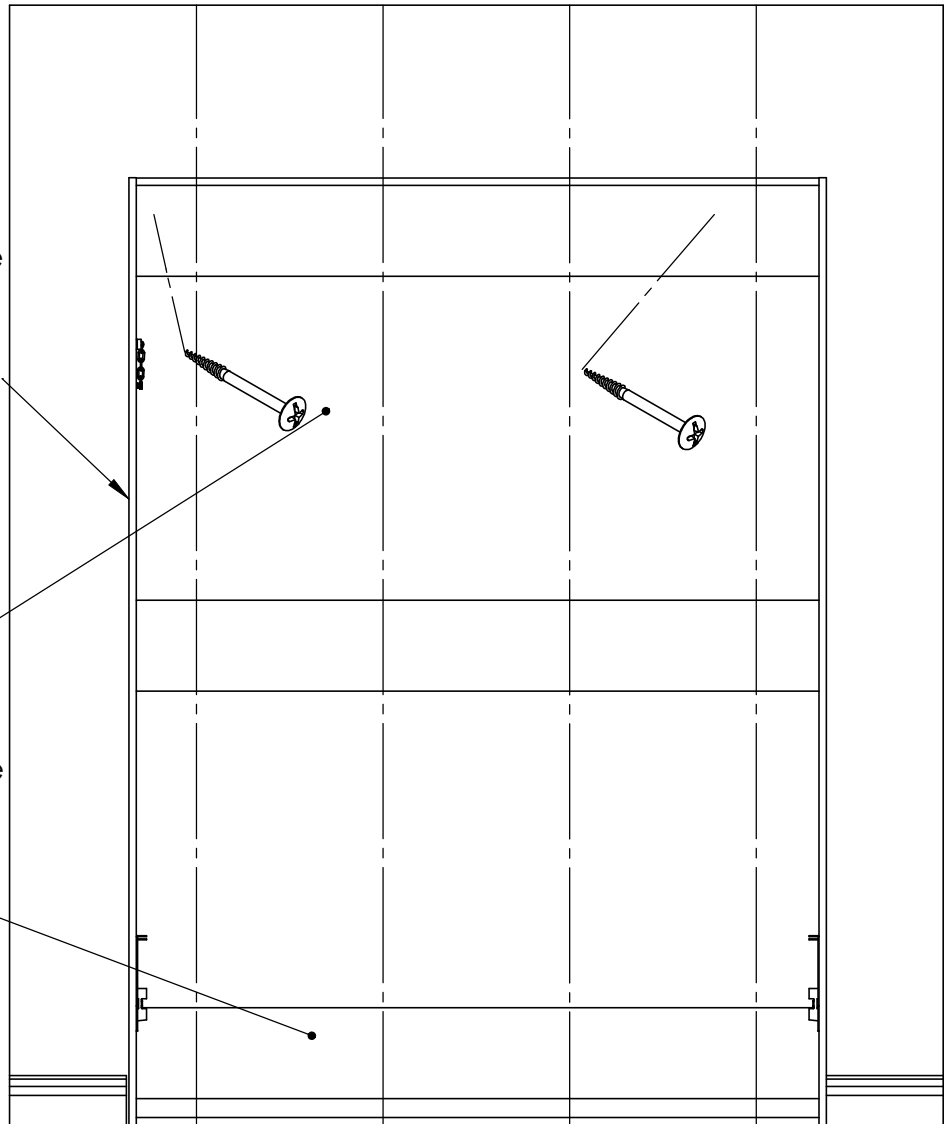

Couper la moulure mural a la largeur du cabinet.  
Cut down wall trim to cabinet size

Item 16 20X

## S 207

### Step 5

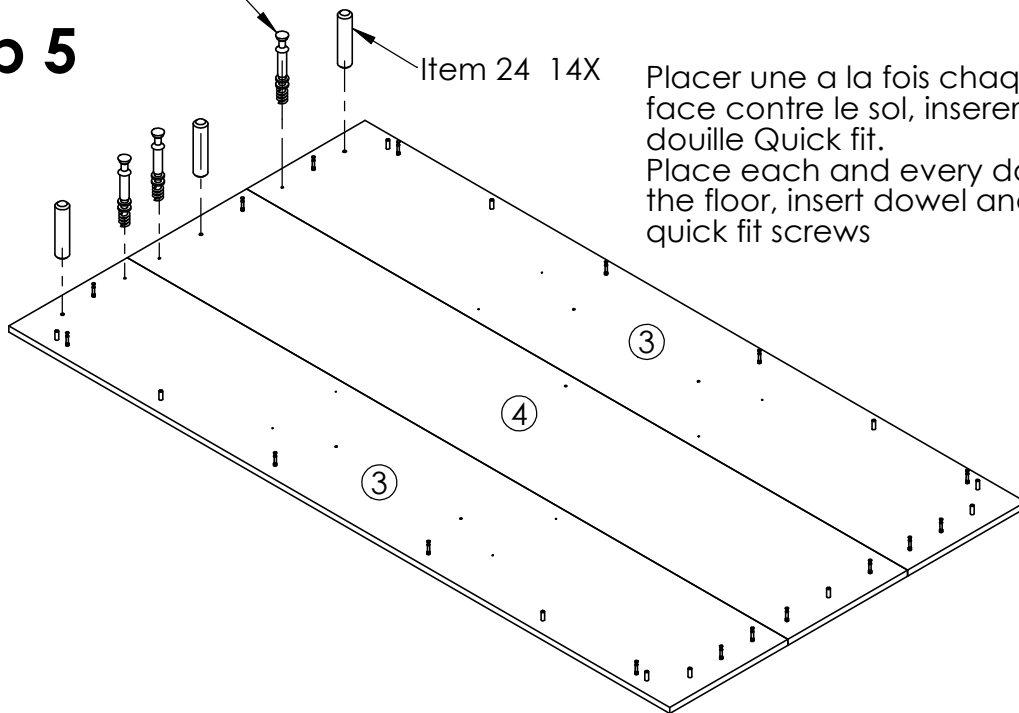

Item 24 14X

Placer une a la fois chaqu'une des portes face contre le sol, inserer goujon et douille Quick fit.  
Place each and every door face down on the floor, insert dowel and secure quick fit screws

### Step 6

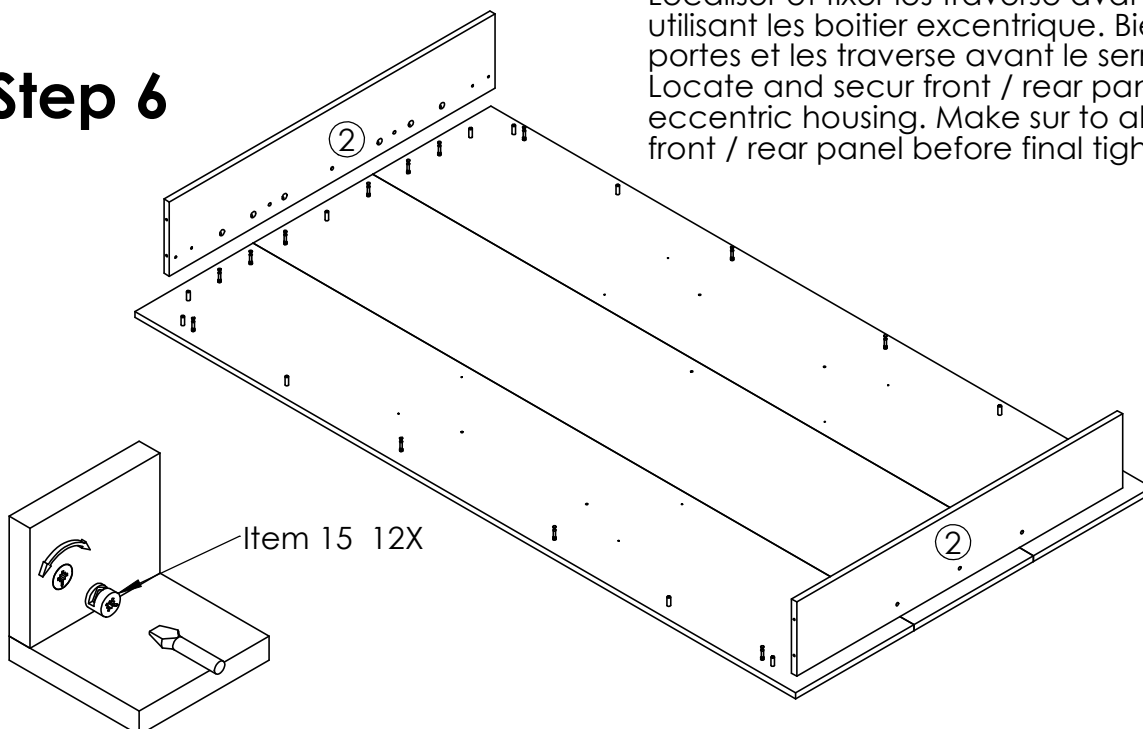

Localiser et fixer les traverse avant / arriere en utilisant les boitier excentrique. Bien aligner les portes et les traverse avant le serrage final.  
Locate and secur front / rear panel using eccentric housing. Make sur to align doors and front / rear panel before final tighten.

Item 15 12X

Inserer le boitier excentrique puis serrer a l'aide d'un tourne vis.  
Insert eccentric housing than tighten with screw driver.

Descendre les côtés 1-1 et 1-2 en places et serrer les bôtiers excentrique, terminer avec les vis d'assemblage.  
 Slide down sides 1-1 and 1-2 first than secur with eccentric housing, finally place and tighten assembly screw.

**S 207**

**Step 7**

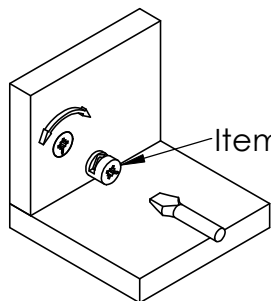

Item 15 8X

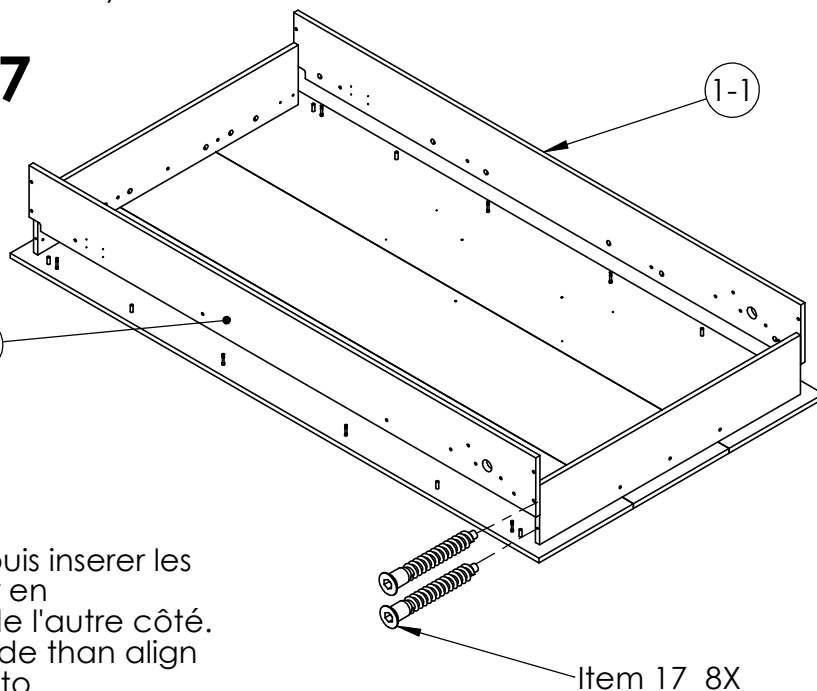

1-2

1-1

Item 17 8X

Plaque renfort placé a l'intérieur puis inserer les boulons M6 à 4 places. Bien serrer en utilisant une clé 10 mm. Repeter de l'autre côté.  
 Reinforcement plate, locate it inside than align with M6 bolt 4 places. Make sure to tighten bolt using 10 mm wrench. Repeat on the other side.

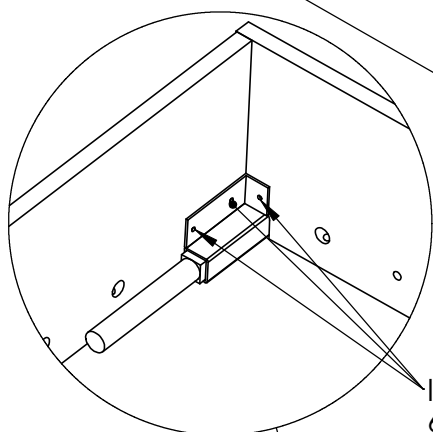

Item 19 6 Places

DETAIL C  
SCALE 1 : 6

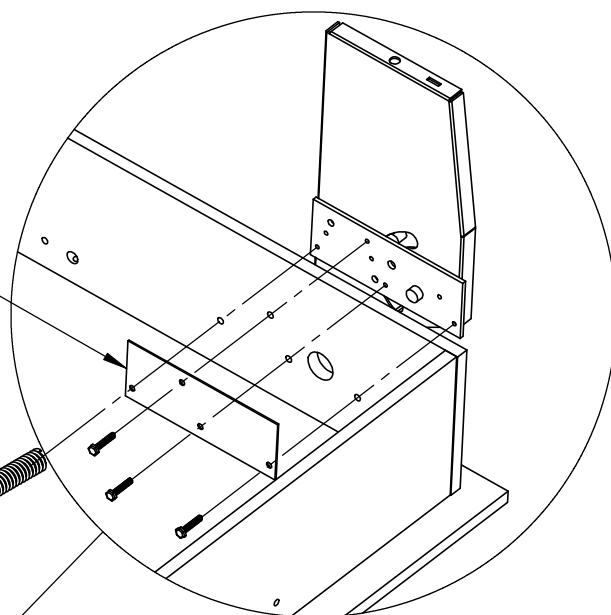

Item 22 8 places

DETAIL A  
SCALE 1 : 8

**Step 8**

## Step 9

S 207

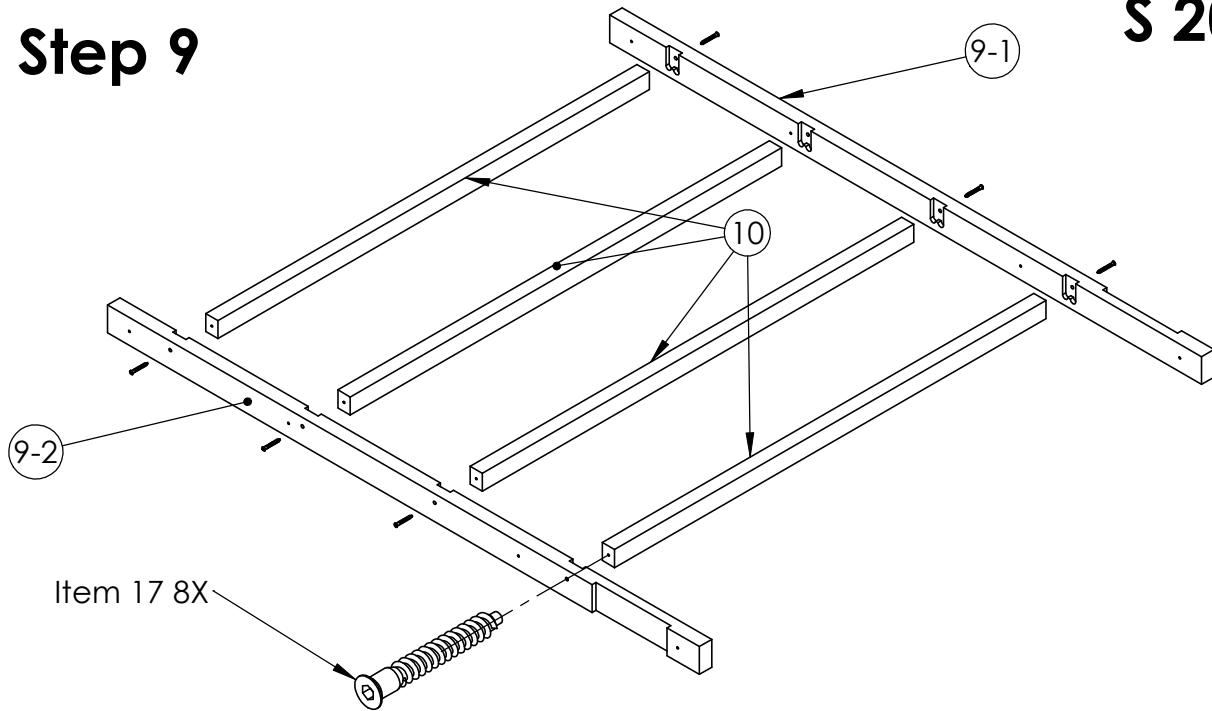

## Step 10

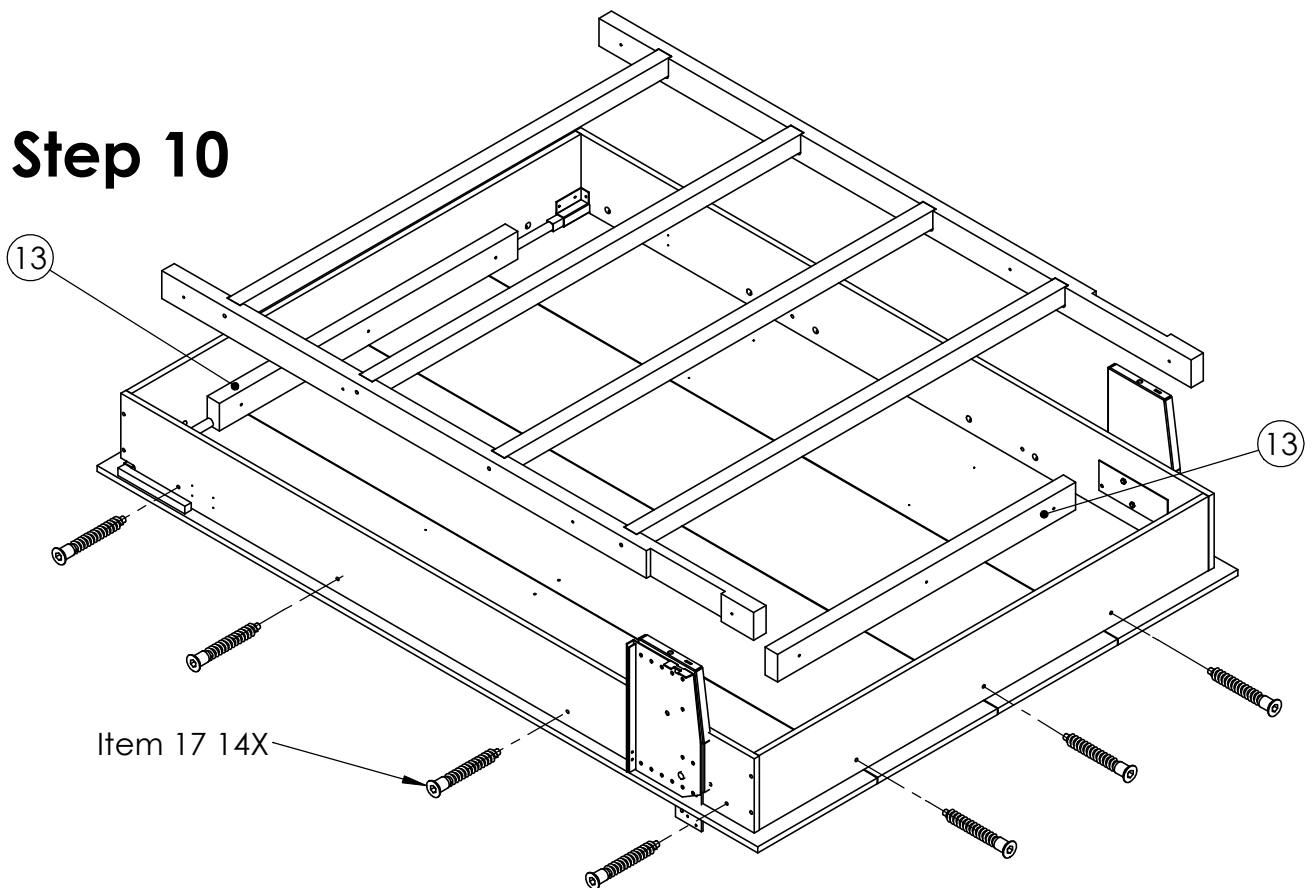

Fixer les traverses de bout #13 en premier puis descendre le cadre et le fixer a l'aide de vis d'assemblage.  
Secure short trim # 13 first than bring down inner frame and secure it using assembly screw.

## Step 11

S 207

Note :

With two people, one on each side, insert bed into cabinet by holding it vertical and parallel to the cabinet. Make sure to align mechanism on each side as shown below.

Avec deux personnes, une de chaque côté, insérer le lit dans le cabinet en le tenant vertical et parallèle au cabinet. Aligner le mécanisme de chaque côté tel que l'image ci-bas.

Insert part A top flat in between Part B opening.

Insérer le plat supérieur de la partie A dans la rainure de la partie B.

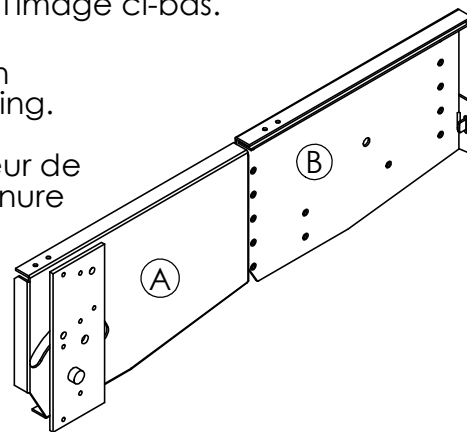
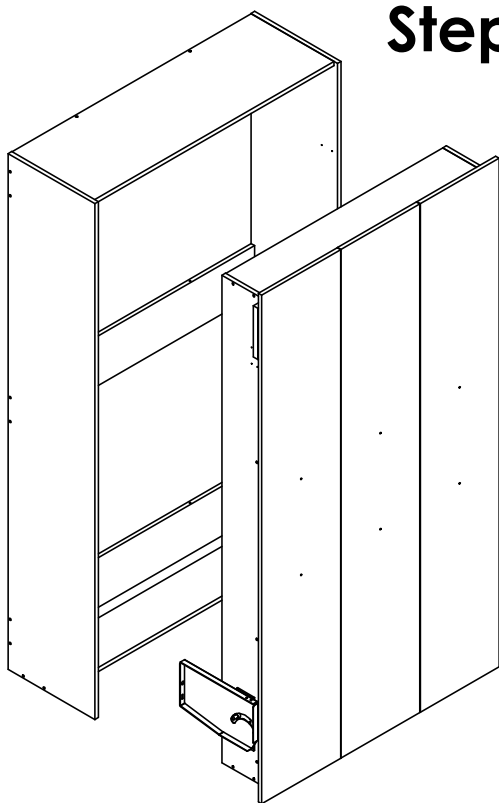

## Warning, Mise en garde

Do not open the bed completely until safety pin is installed, It may result in severe damage to the cabinet and bed parts as well as possible injury to the people.

Ne pas ouvrir le lit complètement tant et aussi longtemps que la tige de sécurité n'est pas en place, il peut en résulter des dommages sévères aux pièces de même que de possible blessure aux installateurs.

Safety pin, one on each side  
Tige de sécurité  
une de chaque côté

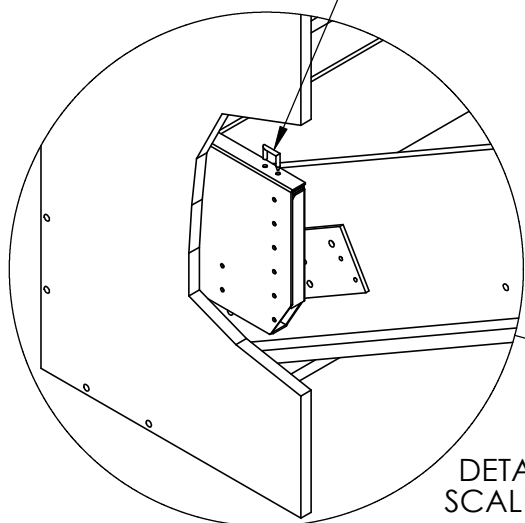

DETAIL H  
SCALE 1 : 8

## Step 12

Open bed about 60 deg. and insert safety pin using hammer neck.

Ouvrir le lit à environ 60 deg. et insérer la tige de sécurité à l'aide du manche du marteau.

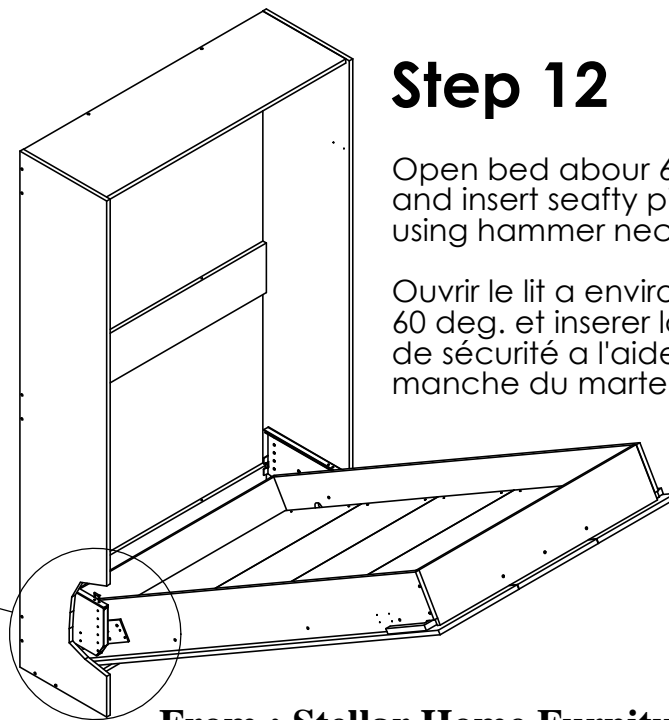

From : Stellar Home Furniture  
Manufactured By : CymeTech inc.  
service@stellarhomefurniture.com



# S 207

Pour les instruction comment inserer la base de lit dans le cabinet, voir aussi les pages # 10 et 11 de cette liste ou le feuillet d'instruction du mécanisme de lit escamotable.

For instruction on how to put together both bed base and wall cabinet also refer to sheet # 10 and 11, or look at instruction sheet with metal collapsible bed.

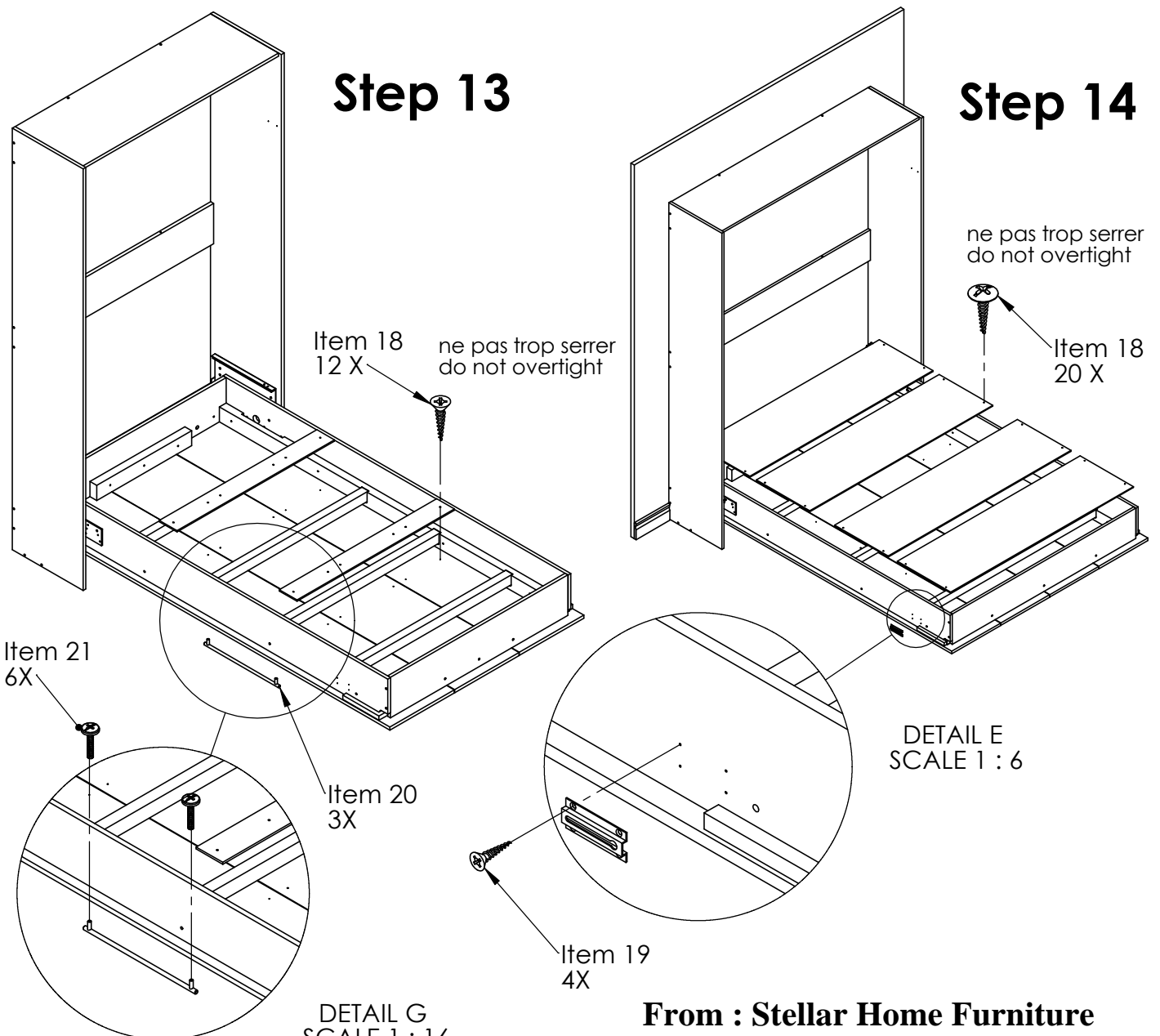

# MLA 108

**MECCANISMO PER LETTO RIBALTABILE SINGOLO (MLA 108/1)**

**DOPPIO (MLA108/2) RINFORZATO (MLA 108/4) -**

MACHINERY FOR SINGLE (MLA 108/1) OR DOUBLE (MLA 108/2) OR HEAVY (MLA108/4) COLLAPSIBLE BED

MÉCANISME POUR LIT RÉCAMPABLE À UNE PLACE (MLA 108/1) À DEUX PLACES (MLA 108/2) RENFORCE (MLA 108/4)

EINZEL KLAPPBETT EINRICHTUNG (MLA 108/1) DOPPEL KLAPPBETT (MLA108/2) VERSTÄRKT KLAPPBETT (MLA 108/4)

28x  **Vite autofilettante per fissaggio meccanismo al mobile**  
Self threaded screw to fix the mechanism on the furniture

4x  **Vite M6 per fissaggio rete a meccanismo MLA 400**  
M6 screw to fix the net to MLA 400

 **1 Sbloccare scatola**  
Unblocking the spring box

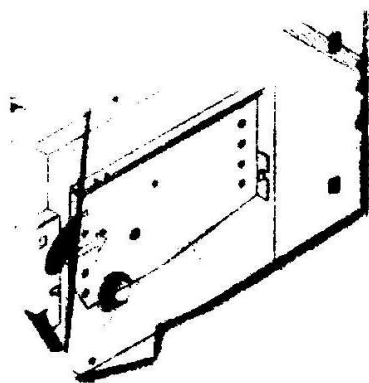

**2 Ingombro Larghezza**

34±1

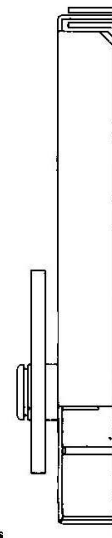

**3 Montaggio controscatola**  
Mounting the box on the cabinet

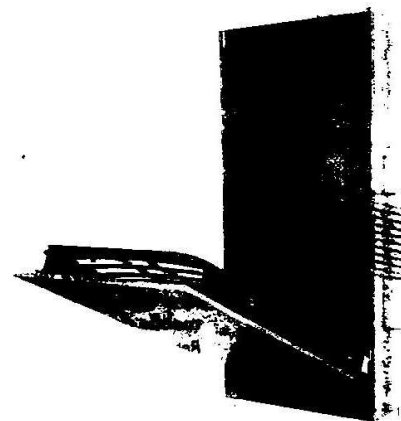
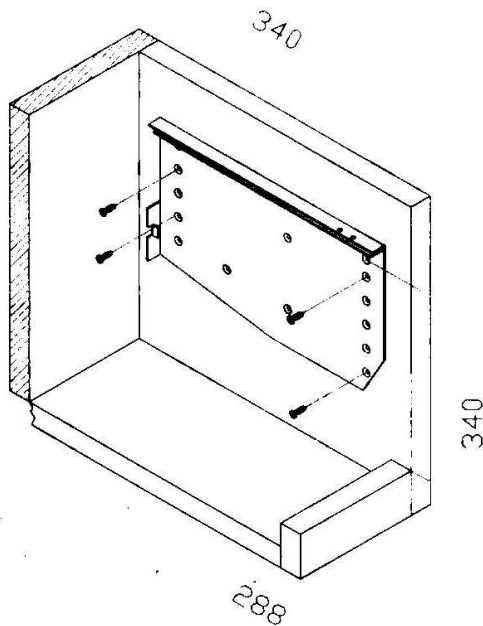

DIS. N° 0949 Rev. 03

**N.B. ATTENZIONE FISSARE SEMPRE IL MOBILE AL MURO**  
N.B. BE CAREFUL ON FIXING ALWAYS THE CABINET TO THE WALL

**4** Montaggio scatola portamolla  
*Mounting the spring box on the bed frame*

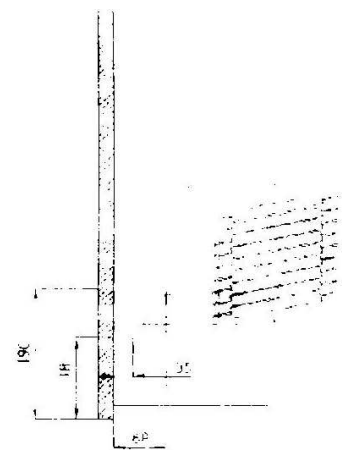
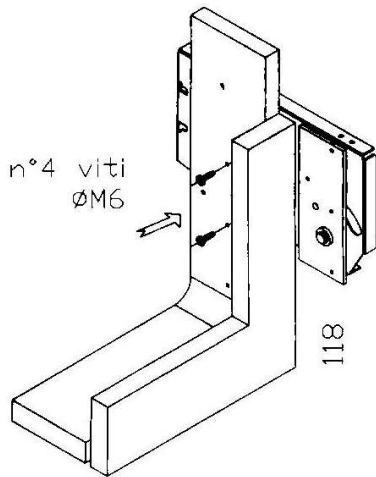

**5** Inserire letto nel mobile  
*Inserting the bed frame into the cabinet after mounting both boxes*

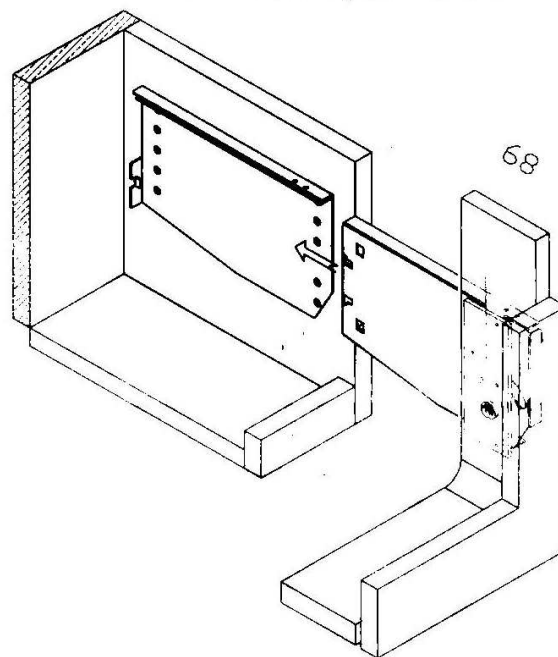

**6** RUOTARE IL MECCANISMO IN POSIZIONE ORIZZONTALE  
*ROTATE THE MECHANISM IN HORIZONTAL POSITION*

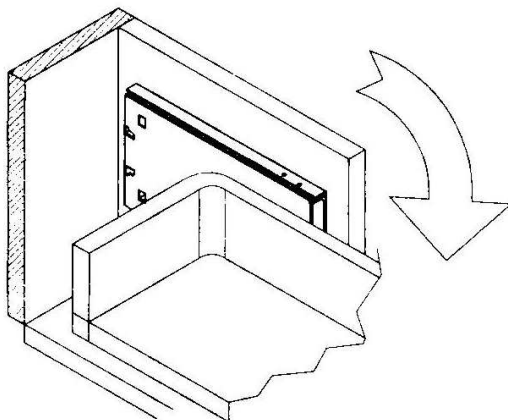

**7** Bloccaggio scatola con controscatola  
*Blocking two parts of the box*

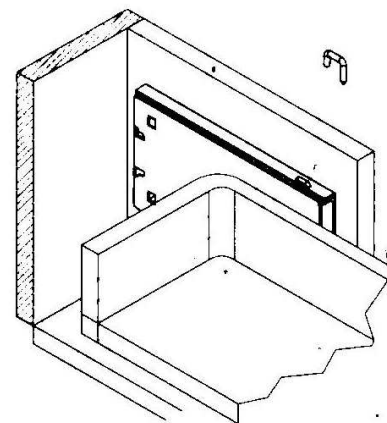

**8**

Regolazione tensione mobile portare il letto in posizione orizzontale, e regolare la tensione delle molle per ottenere il perfetto equilibrio. Questo può essere verificato assicurandosi che il letto rimanga fermo in qualsiasi posizione di apertura. L'aria tra il cassonetto e i fianchi del mobile deve essere di 32:33 mm per parte.

*Regulation of the spring tension by acting on the bolt placed on the back of the springs box  
 To obtain a perfect regulation the bed must stop in each opened position, you may leave it. Distance between bed's frame and cabinet must be 32.33 mm*