

OWNER'S MANUAL

IRONMAN

MASSAGE TABLE

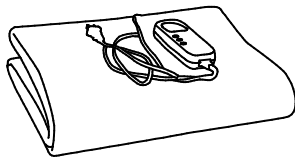
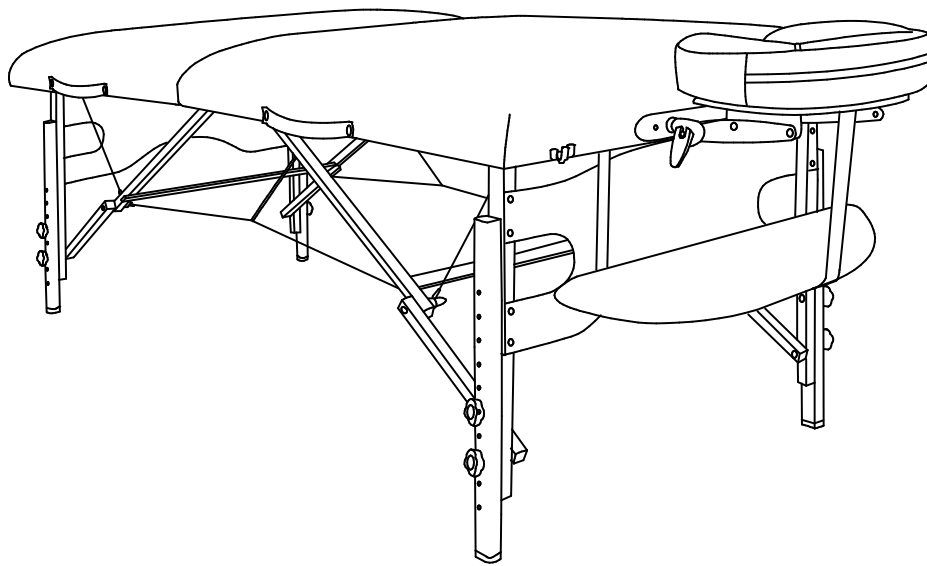

Heating Pad

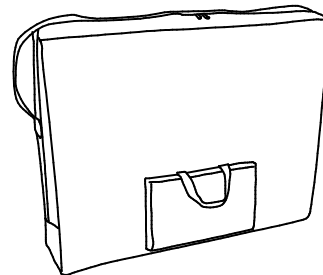

Deluxe Carry Bag

Model # 9107

The specifications of this product may vary from this photo and are subject to change without notice.
IRONMAN, IRONMAN TRIATHLON AND M-DOT are registered trademarks of World Triathlon Corporation.
This product is licensed by the IRONMAN TRIATHLON.

TABLE OF CONTENTS

	<i>Page #</i>
Warning label placement	3
Service	4
Important safety instructions	5
Overview drawing	7
Part list	8
Assembly	9
Adjustments	12
Operating the controller	13
Maintenance and cleaning	15
Storage	16
Transporting the table	17
Warranty	17
Part request fax form	18

WARNING LABEL PLACEMENT

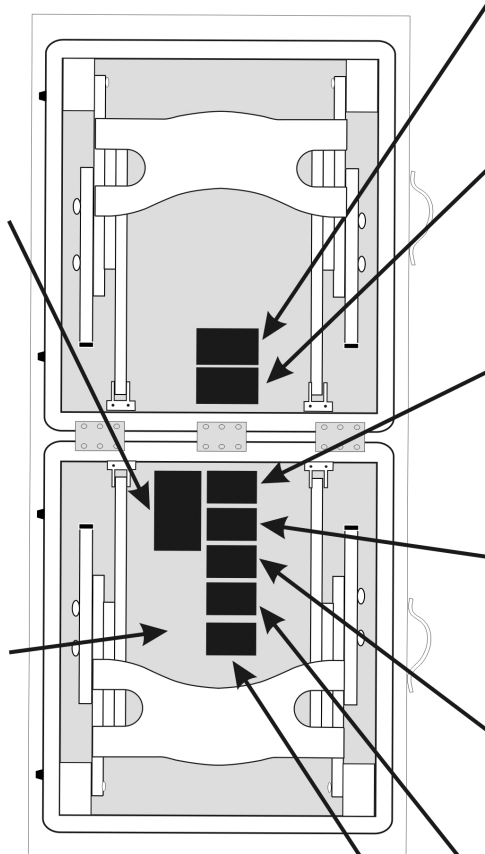
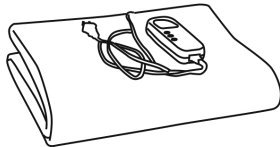
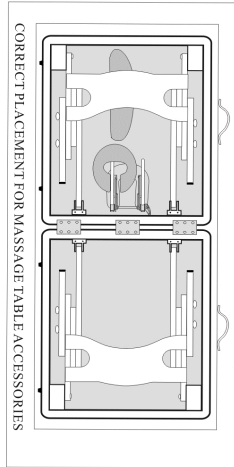

Not to be removed until all items are in compliance with Personal Care.	No plus retirer avant la fin de la conformité.
This article complies with the requirements of the Personal Care Act.	Cet article est conforme aux exigences de la Loi sur le bien-être personnel.
Made in Canada / NEW MATERIAL ONLY	Fabriqué au Canada / NOUVEAU MATÉRIEL SEULEMENT
Made by reg. no. 1097-228-9397	Fabriqué par no. de permis 1097-228-9397
Canada / Patented in France	Canada / Breveté en France

Under Product of the Register Inventor/Manufacturer/Supplier: ALL NEW MATERIAL CONSISTING OF PERSONAL-CARE/BIEN-ÊTRE, INC. REGISTRY NO. 151321	NOTICE THIS ARTICLE MEETS THE LIABILITY REQUIREMENTS OF CALIFORNIA REGULATION 160000 REGARDING TECHNICAL BULLETIN 117-CARE BODILO BE OBSERVED NEAR OPEN FLAME OR WITH BURNING COAGULATES
---	--



WARNING Maximum weight capacity: Static weight 2000 LBS / 909KGS Working weight 500 LBS / 227KGS	AVERTISSEMENT Le poids maximum Le poids statique 2000 LBS / 909KGS Le poids actif 500 LBS / 227KGS
--	--

CAUTION Do NOT Sit on the extreme edge of the table, doing so may cause the table to fold or collapse and cause the table damage or personal injury.	ATTENTION Ne vous asseyez pas sur le bord extrême de la table, pendant que faire peut causer aussi la table de plier ou à s'écrouler et causer la dégradation de la table ou blessure personnelle.
--	--

CAUTION When getting up from the table, please do not use the armrest to push yourself up as the armrest will break.	ATTENTION En se levant de la table, svp n'utilisez pas l'accoudoir pour se relever car l'accoudoir se cassera.
--	--

For Customer Assistance Call: 1-866-924-1688 8:00 am - 5:00 pm (PST) Monday to Friday	Pour le service à la clientèle composer le: 1-866-924-1688 Du lundi au vendredi 8:00 h - 17 h (HNP)
---	---

SERVICE

To request for product service and order replacement parts, please call our customer service department at

1-866-924-1688

Monday through Friday, 8:00 am-5:00 pm Pacific Standard Time,
or email at: **service@paradigmhw.com**

Please have the following information ready when requesting for service:

Your name	Phone number	Owner's manual
Model number	Serial number	Part number
Date of Purchase		

***If the product has major defects which prevent it from functioning properly, please return it to the store of purchase within the period allowed by the store.**

Paradigm Health & Wellness, Inc.
1189 Jellick Ave.
City of Industry, CA 91748

IMPORTANT SAFETY INSTRUCTIONS

For Massage Table:

1. Maintain the table periodically. Make sure all screws are secure and the cable has not deteriorated or frayed. Make sure there are no cracks in the wood structure.
2. Do not overload the table beyond the recommended weight limit. This could result in serious injury to the user.
3. Do not use alcohol based cleaners when cleaning the vinyl. This could cause damage to the vinyl material. Use warm soapy water and wipe dry.
4. Make sure when using the table that all four legs are at the same level. Using the legs at different levels can cause the table to be unstable and cause injury.
5. Maximum weight capacity- static weight: 2000 lbs/909 kgs
working weight: 500 lbs/227 kgs

For Heating Pad:

Read all instructions carefully before using this heating pad. Retain this owner's manual for future reference.

1. Use this heating pad only for its intended use as described in this manual. Do not use attachments not recommended by the manufacturer.
2. The heating pad should never be left unattended when plugged in. Always unplug this heating pad from the electrical outlet immediately after using and before cleaning.
3. Do not insert pins into the heating pad.
4. Never operate this heating pad if it has a damaged cord or plug. If it is not working properly, if it has been dropped or damaged, or dropped into water. Return the heating pad to a service center for examination and repair.
5. Do not carry this heating pad by supply cord or use cord as a handle.
6. Keep the cord away from heated surface.
7. Do not use outdoors.
8. Do not operate where aerosol (spray) products are being used or where oxygen is being administered.
9. To disconnect, please turn the power switch of the controller to the OFF position, then remove plug from electrical outlet.
10. This heating pad is not intended for medical use in hospitals.
11. Do not use the heating pad with another heating appliance together.
12. Do not use the heating pad on any type of conventional bed, pull-out bed or fold-up bed.
13. This heating pad is not intended for use by persons (including children) with reduced physical, sensory or mental capabilities, a helpless person, an infant or a person insensitive to heat.

14. This heating pad is not intended for use by young children or infirm persons without supervision or instruction concerning use of the appliance by a responsible person.
15. Examine the heating pad frequently to check that there are no signs of wear or damage. If the heating pad is malfunctioning, discontinue immediately and consult with the manufacture for repair.
16. For Household Use Only.

OVERVIEW DRAWING

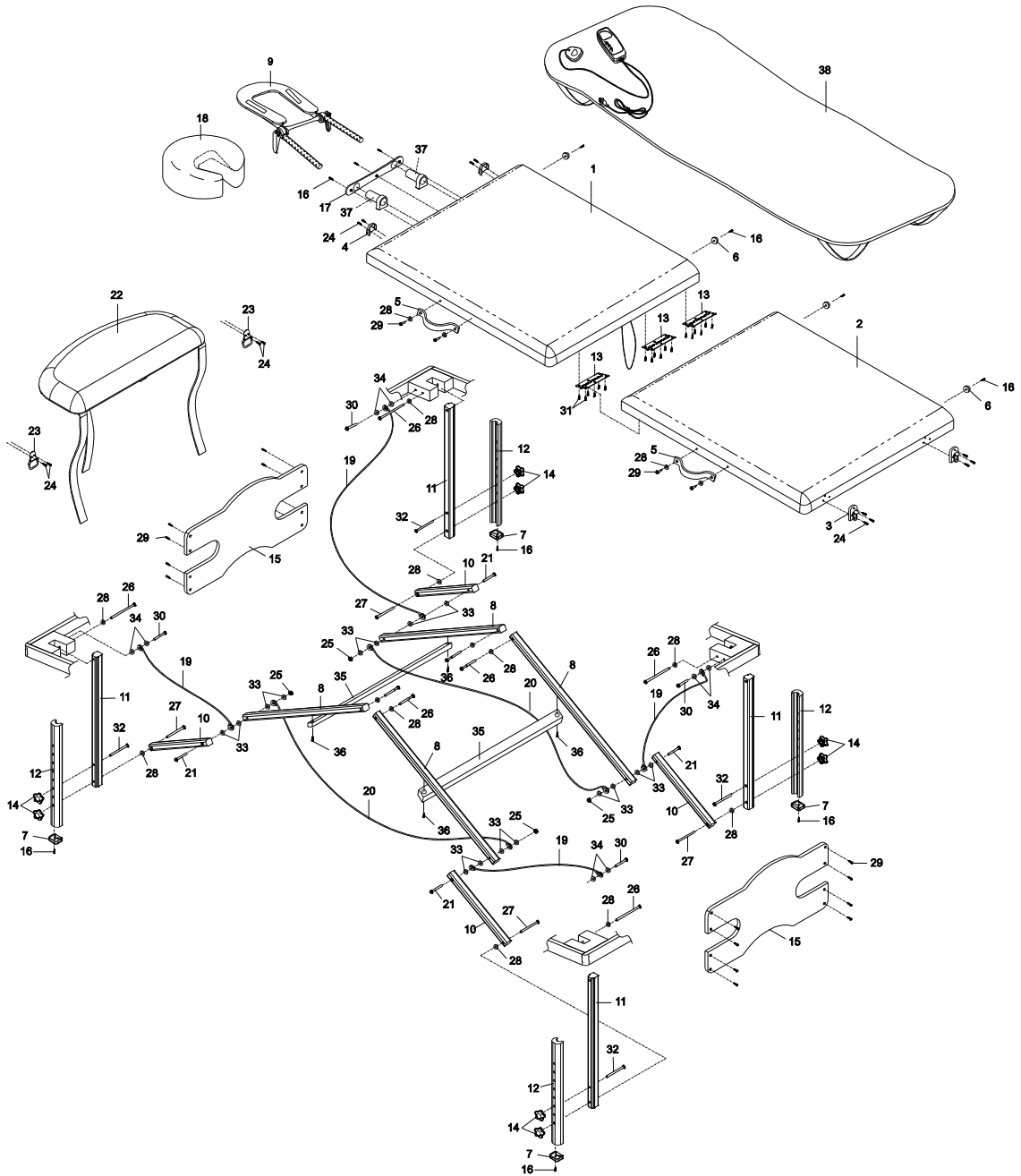

PART LIST

Part#	Description	Quan.	Part#	Description	Quan.
001	Front Bed with Frame	1	020	Long Cable	2
002	Rear Bed with Frame	1	021	M6x65mm Self Tapping Bolt	4
003	Upper Buckle	2	022	Armrest	1
004	Lower Buckle	2	023	Armrest Loop	2
005	Handle	2	024	M3x20mm Round Head Self Tapping Screw	14
006	Rubber Foot	4	025	M6 Nylon Nut	4
007	Lower Leg End Cap	4	026	M6x75mm Bolt	8
008	Long Brace	4	027	M6x75mm Self Tapping Bolt	4
009	U Shaped Headrest	1	028	Plastic Washer Ø18xØ6x2t	16
010	Short Brace	4	029	M4x18mm Mod. Truss Head Screw	20
011	Upper Leg	4	030	M6x30mm Bolt	4
012	Lower Leg	4	031	M4x20mm Self Tapping Screw	18
013	Hinge	3	032	M6x50mm Self Tapping Bolt	4
014	Leg Knob	8	033	Plastic Washer Ø13xØ6x2t	16
015	End Panel	2	034	Plastic Washer Ø15xØ6x4t	8
016	M4x20mm Round Head Self Tapping Screw	11	035	Cross Brace	2
017	Headrest Bushing Plate	1	036	M4x20mm Self Tapping Bolt	4
018	Face Cushion	1	037	Bushing	2
019	Short Cable	4	038	Heating Pad	1 Set

ASSEMBLY

1

Release the Buckles and then open the table. Take out the Face Cushion, U Shaped Headrest, Armrest, and Heating Pad from underneath of the table.

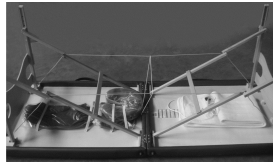

2

Pull out the left and right pair of Legs and straighten each joint.

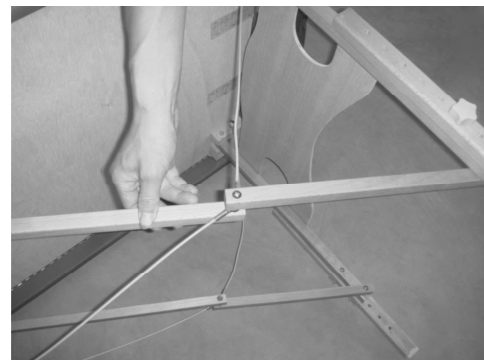

3

Lift the table up until all four legs are on the floor.



ASSEMBLY

4

Lift one end of the table and pull out to open table fully.



5

Insert both Right/Left Headrest Sticks with Headrest into the holes of the Headrest Bushing Plate.



6

Attach armrest corner straps onto Armrest Loops underneath the Front Bed.



ASSEMBLY

7

Attach front strap to the U Shaped Headrest.

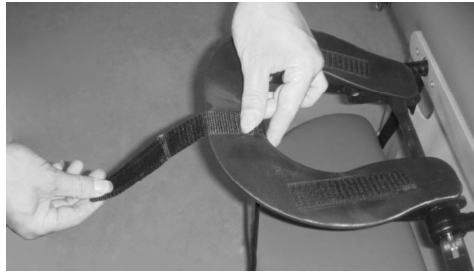

8

Place the Face Cushion onto the U Shaped Headrest by lining up the Velcro pads.

WARNING: HEADREST IS FOR LIGHT USE ONLY! PLEASE DO NOT PLACE HEAVY WEIGHT OR STRONG PRESSURE WHEN RESTING.



9

Use the elastic corner straps on the Heating Pad to hold the massage table in place and prevent them from slipping.

Ensure when fixing the Heating Pad to the massage table, it will not move or crease. (The creased part tends to cause high temperature which is very dangerous.)



ADJUSTMENTS

Adjusting the angle of the Headrest

Press up on the Locking Handles and then adjust the Headrest to the desired angle. Press down on the Locking Handles after adjustment to lock into place.



Adjusting the Table Height

Lay the table on the Rubber Footed side and then remove the Leg Knobs.

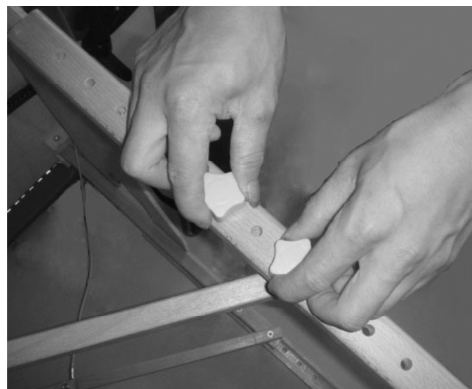

Remove the Lower Leg and then place the Lower Leg back onto the Upper Leg matched up to the desired holes for adjusting the height of the table.

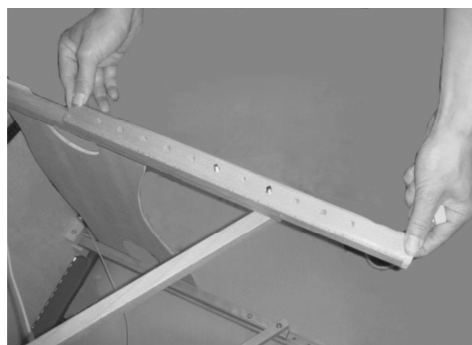

Tighten the Leg Knobs after adjustment.

NOTE: Adjust all of the four Legs to the same height.

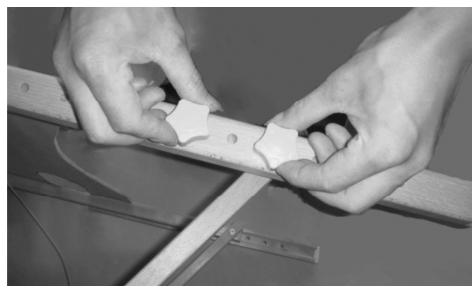

OPERATING THE CONTROLLER

USING THE HEATING PAD

Do not cover the controller and exert pressure on the controller.

Plug this heating pad from the electrical outlet. Turn the power switch of the controller to the “ON” position and the power indicator light should light up. Press the temperature set button until 5 LED’s are lit up (Maximum heat). It will take at least 30 minutes to get to the maximum heat. Once it has reached to the maximum heat, you can press the temperature set button to set the heat level. The guide below gives you an indication of the heat levels and what the number of lit LED’s mean in terms of the level of heat.

To prevent the heating pad from getting too hot, the heat level will automatically reduce to a low heat level after being on maximum heat for one hour. When the heating pad is likely to be used for an extended period, it is suggested that the controller should be adjusted to low heat level 1 or 2 (1 or 2 LED’s are lit up). Please preheat the heating pad for 30 minutes to 1 hour before use.



Press times	Temperature LED	Power	Heating state
One	One LED	Pe25 %	Weaker
Two	Two LEDs	Pe40 %	Weak
Three	Three LEDs	Pe55 %	Middle
Four	Four LEDs	Pe70 %	Strong
Five	Five LEDs	Pe100%	Stronger
Six	One LED	Pe25 %	Weak
.....

← After one hour change automatically

The controller has a timer function (Middle button) which allows you to control how long you want the heating pad to be used. You can set it for up to 8 hours in hourly timings. The amount of time in “time mode” will be accumulated by the number of times you press the time set button on the controller. For example, press the time set button 3 times and it will set for 3 hours. If you want to cancel the timer, press the cancel button (Bottom button) and all settings will cease. To resume, you will have to input the settings using the time set button again.

If the indicator lights (LED’s) alternately flash, check the connector (plug) and ensure

the controller is fully connected to the heating pad. Press the cancel key to cancel the flashing, then reset to the required function. If the indicator lights (LED's) simultaneously flash, check if the throw/over heating pad is folded or tucked, spread the throw/over heating pad, press the cancel key to cancel the flashing, after several minutes reset to required function. If you cannot cancel the flashing, you should unplug the heating pad from the electrical outlet and check the lead is damaged or not. If the flashing continues, the heating pad must not be used and be checked by a qualified repairer.

Timer modes

Press times		one	two	three	four	five	six	seven	eight	nine	...
Corresponding Time set light Show on	1h	☐		☐		☐		☐		☐	
	2h		☐	☐			☐	☐			...
	4h				☐	☐	☐	☐			
	8h								☐		
Switch on time(h)		1	2	3	4	5	6	7	8	1	...

AFTER USING THE HEATING PAD

When the heating pad is not in use, please turn the power switch of the controller to the "OFF" position, unplug the heating pad from the electrical outlet. If the heating pad is not to be used for a long period of time, store it in a cool and dry place.

MAINTENANCE AND CLEANING

For Massage Table:

You should check your massage table for any kind of wear and tear before each and every use.

1. Check the legs, bed and cables for wear and tear.
2. Replace damaged and worn components immediately.
3. Keep all damaged equipment out of use until it is repaired.

For Heating Pad:

1. Always unplug this heating pad from the electrical outlet immediately after using and before cleaning.
2. Clean the surface of the cord with soft cloth.
3. Do not submerge the controller in the water or get it wet at all.
4. Do not dry clean this heating pad.
5. To clean the heating pad, wipe it down with a soft damp cloth and very mild detergent. The heating pad should be hung in a ventilated location to dry naturally.
7. Do not use industrial solvents such as benzene, kerosene or similar solvents to clean the heating pad.
8. Do not connect the heating pad to power supply to dry it.
9. Do not dry the heating pad under the sun.
10. Do not iron the heating pad.
11. Do not use an appliance such as a hair dryer to dry the heating pad.
12. Allow the heating pad to dry naturally.
13. Do not use the heating pad if it is damp or wet.

STORAGE

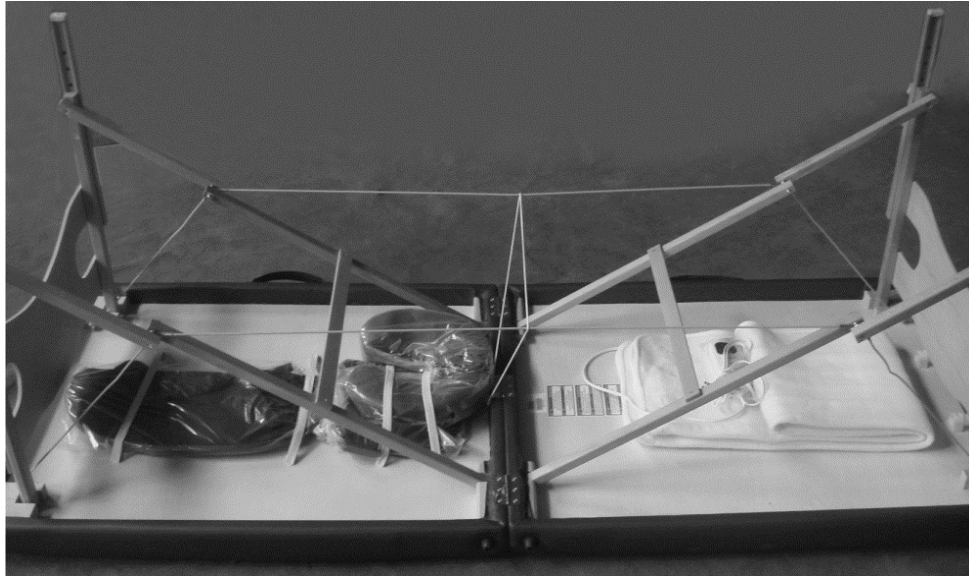

For Massage Table:

1. Place the massage table upside down on the floor.
2. Completely fold the legs flat under the table.
3. Make sure the Cables, U Shape Headrest, Face Cushion, Armrest, and Heating Pad are inside the table before closing it.

For Heating Pad:

1. When not in use, allow the heating pad to cool down before folding, then gently fold it.
2. Make sure the heating pad is dry before folding. The heating pad should be hung in a ventilated location to dry naturally.
3. Insulation of the heating pad will be damaged if it is dried under the sun or ironed. Damage on the insulation material will cause safety problem.
4. The heating pad should be folded without any crease and store it in a cool dry place.

TRANSPORTING THE TABLE



The table is easy to carry with the shoulder strap of carry bag.

WARRANTY

Paradigm Inc. warrants to the original purchaser that this product is free from defects in material and workmanship when used for the purpose intended, under the conditions that it has been installed and operated in according to Paradigm's Owner's Manual. Paradigm's obligation under this warranty is limited to replacing free of charge, any parts which may prove to be defective under normal home use. This warranty does not include any damage caused by improper operation, misuse or commercial application. From the date of purchase, the frame is warranted to be free from defects for 1 (one) year. All parts and workmanship, including electronics and its console cases, upholstery, foam, ball bearings, pulleys, cables, shocks, all tension mechanisms, wheels, pedals and hardware are to be free from defects for 90 days. This warranty is offered only to the original owner and is not transferable. Proof of purchase is required.

OFFICIAL USE ONLY

SHIP DATE: _____

TRK #: _____

BACK ORDER: _____