

Climb & Play Sets-Assembly Guide

Model #ELR-0788-3 pc. Climb & Play Set
Model #ELR-0789-8 pc. Climb & Play Set
Model #ELR-0790-12 pc. Climb & Play Set
Model #ELR-0791-17 pc. Climb & Play Set

PARTS LISTS

ELR-0788-3 pc. Climb & Play Set



ELR-0789-8 pc Climb & Play Set

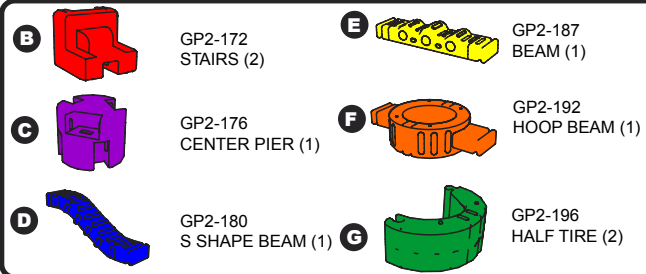

ELR-0790-12 pc. Climb & Play Set

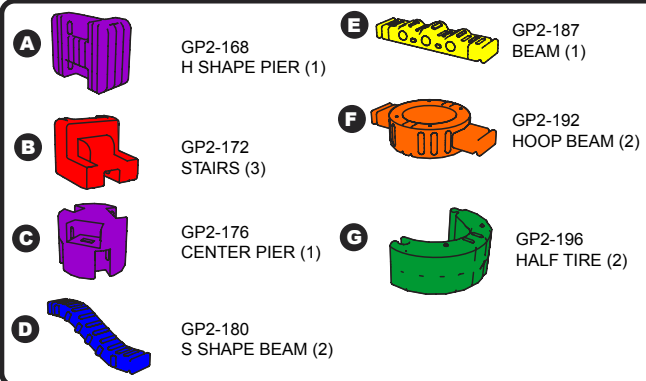

ELR-0791-17 pc. Climb & Play Set

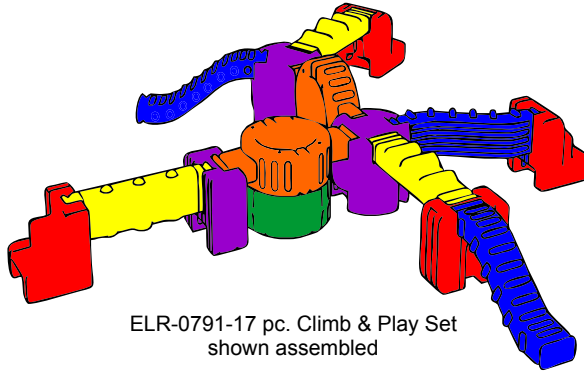
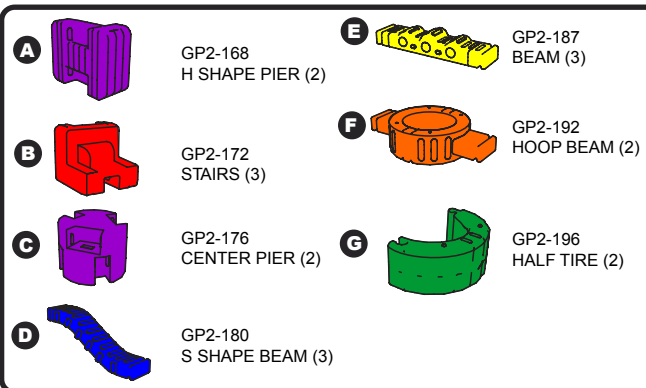

ELR-0791-17 pc. Climb & Play Set
shown assembled

BEFORE ASSEMBLING,
MAKE SURE THERE
ARE NO
MISSING PARTS.

If you experience any difficulties
with this product, please email us at
customerservice@ecr4kids.com
or call toll free at 1-888-227-9028
(Mon. through Fri., 9:00am to 5:00pm
Eastern Standard Time).
Please do not return to place of purchase
as Early Childhood Resources
will replace defective part(s) and/or product.

! WARNING:

- Adult Assembly Required.
- Maximum Weight Capacity: 130 LB (60 KG)
- Recommended Age: 3 - 6 Years
- Recommended Height: 30"+
- Never leave children unattended.

TO AVOID SERIOUS INJURY:

- Continuous Adult Supervision Required.
- Never use near motor vehicles, streets, swimming pools, hills, steps or sloped driveways.
- Always wear shoes when using this unit.
- Do not lean or pull on unit for support.

General Assembly Tips:

Most pieces in all of the sets can be assembled in several different ways. By flipping the piers and rotating the beams, the configurations can be made more challenging, easier, or different to increase the enjoyment!

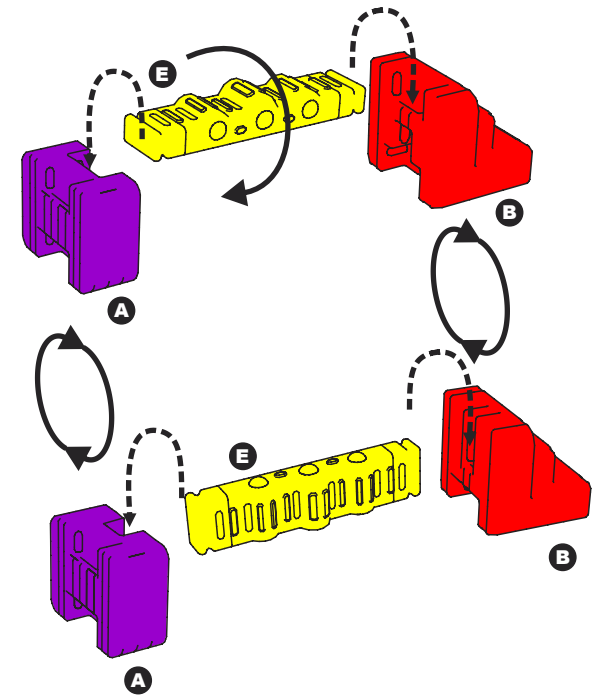

The example above illustrates how flipping the H Shape Pier(A) and Stairs(B) allow the Beam(E) to rotate and connect to the narrower slots, resulting in a narrower beam.

This allows a large variety of configurations and creative experimentation is encouraged.

The following pages show an example of one suggested configuration for each set.

ELR-0788 3 pc. Climb & Play Set

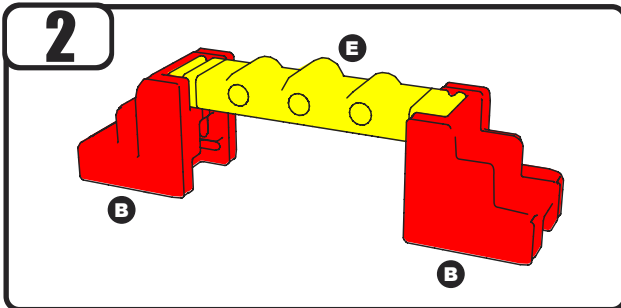
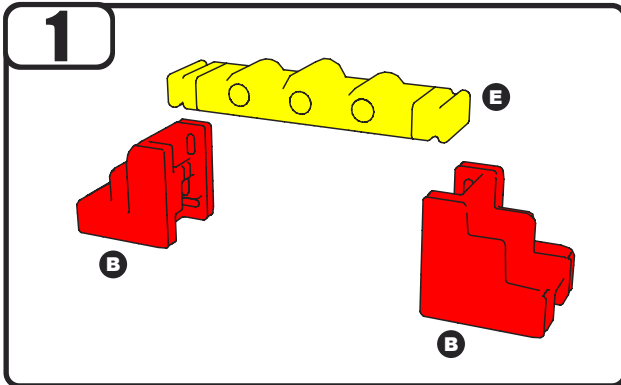

1. Connect the Beam(E) to the Stairs(B) as shown.

The Stairs(B) can be flipped to allow the Beam(E) to rotate and connect to the narrower slots, resulting in a narrower beam (not shown). The Beam(E) can also be rotated to any of 4 sides to access different patterns for variety.

2. Make sure Beams(E) are fully inserted and locked into position before use.

ELR-0789 8 pc. Climb & Play

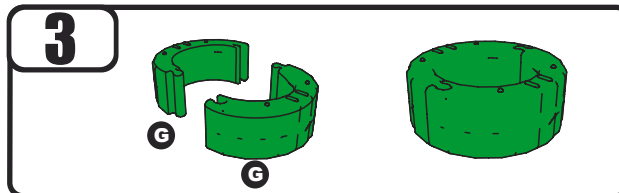
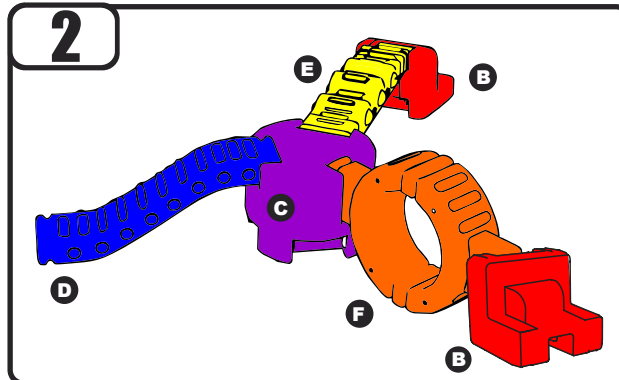
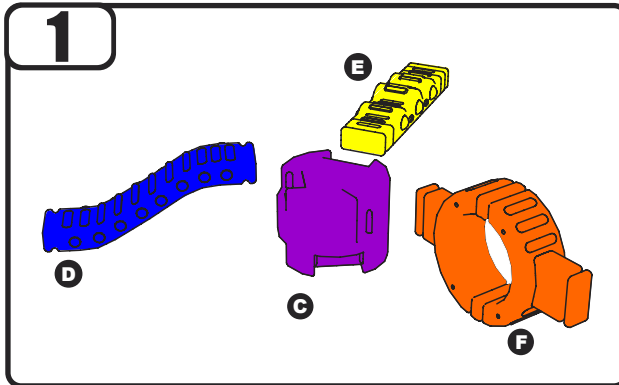

1. Place the Center Pier(C) so that the end with 3 slots is on top. Attach 3 Beams(D, E & F) as shown.

2. Attach Stairs(B) to ends of Beam(E) & Hoop Beam(F).

The Beams(D, E & F) can be rotated to any of 4 sides to access different patterns for variety. Make sure all Beams(D, E & F) are fully inserted and locked into position before use.

3. Assemble 2 Half Tires(G) for an additional challenge or place under Hoop Beam(F).

ELR-0790 12 pc. Climb & Play

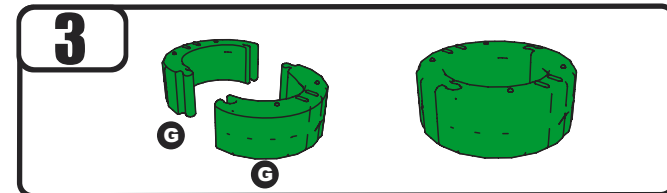
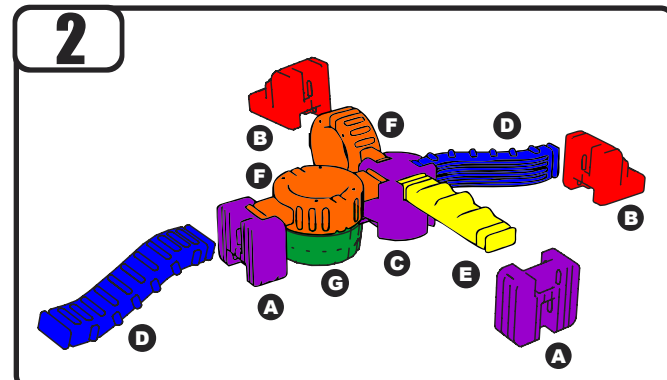
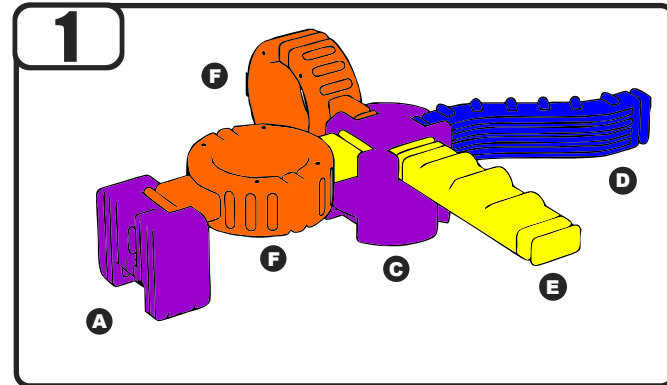

1. Place the Center Pier(C) so that the end with 4 slots is on top. Attach 4 Beams (D, E, & F) as shown.

2. Attach Stairs(B) to ends of Beam(D) and Hoop Beam(F). Attach H Shape Piers(A) to ends of Beam(E) and Hoop Beam(F). Attach S-Shape Beam(D) to H-Shape Pier(A).

The Beams(D, E & F) can be rotated to any of 4 sides to access different patterns for variety. Make sure Beams(D, E & F) are fully inserted and locked into position before use.

3. Assemble 2 Half Tires(G) for an additional challenge or place under Hoop Beam(F) as shown in Step 2.

ELR-0791 17 pc. Climb & Play

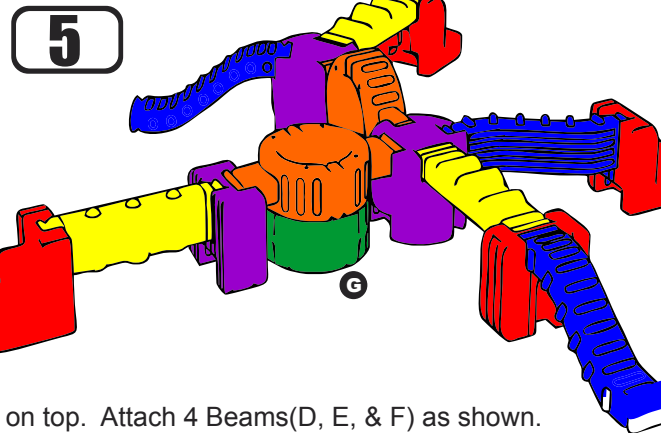
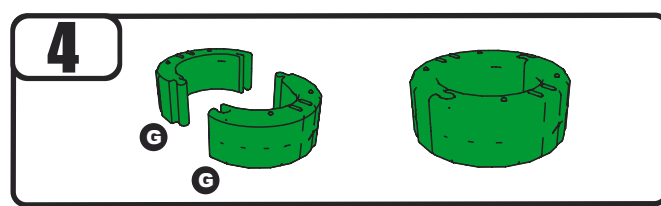
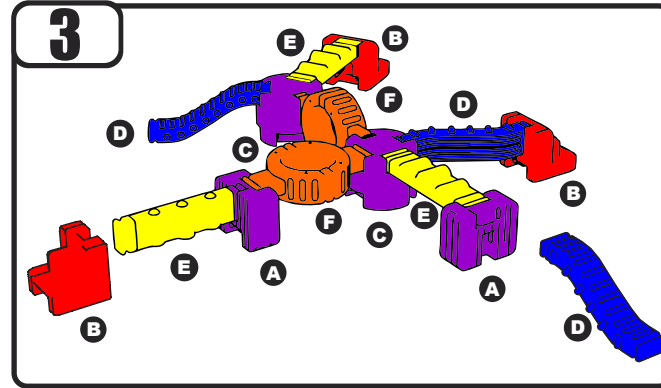
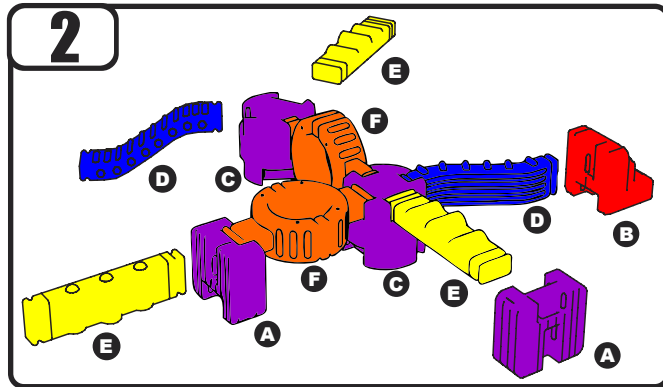
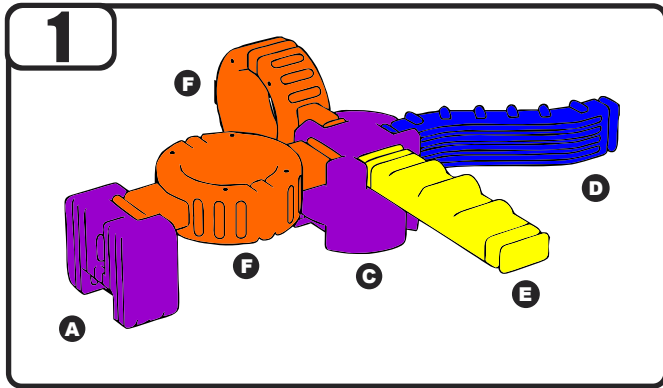

1. Position the Center Pier(C) so that the end with 4 slots is on top. Attach 4 Beams(D, E, & F) as shown. Attach H-Shape Pier(A) to end of Hoop Beam(F).

2. Attach Stairs(B) to end of Beams(D & E). Attach H-Shape Piers(A) to ends of Beam(E). Attach Center Pier(C) so that the end with 3 slots is on top to Hoop Beam(F). Attach Beams(D & E) to Center Pier(C).

3. Attach 2 more Stairs(B) to end of 2 Beams(E). Attach S-Shaped Beam(D) to end of H-Shape Pier(A)

The Beams(D, E & F) can be rotated to any of 4 sides to access different patterns for variety. Make sure all Beams(D, E & F) are fully inserted and locked into position before use.

4. Assemble 2 Half Tires(G) for an additional challenge or place under Hoop Beam(F) as shown in Step 5.

Early Childhood
RESOURCES

We appreciate your purchase of the Climb & Play Center. Early Childhood Resources® has made every effort to supply a quality product, that with proper use and care, will bring you many years of trouble free use!

Care and Cleaning

Clean with a damp cloth or sponge using warm water and mild soap. Wipe dry.

Do not place near heat, moisture or vaporizer.

Check for loose, worn or broken parts periodically and replace as necessary.



"Early Childhood Resources® guarantees the quality of all of our products. You can trust the quality and safety of our furniture and materials, along with the peace of mind that our products are made to last. If for any reason, you are not satisfied with the quality and workmanship of our products, we will replace the item or refund the sale."

Record the manufacture date here. Information is located on a label enclosed and on the shipping carton. Place label and this sheet in an accessible place.

Model Number: _____

Purchase Order Number: _____