

## RECTANGULAR SHADE STRING PENDANT LAMP

### READ ALL INSTRUCTIONS BEFORE USING

Thank you for purchasing the Sharper Image® Rectangular Plisse Shade Pendant Lamp. This product, along with the entire Sharper Image® Home Collection, connects innovation with cutting-edge design to provide you with years of dependability and enjoyment.

### IMPORTANT SAFEGUARDS







- FOR BEST RESULT, HAVE LIGHTING PROFESSIONALLY INSTALLED BY A QUALIFIED LICENSED ELECTRICIAN
- When using electrical products, especially when children are present, basic safety precautions should be followed.

### CAUTION:

To reduce the risk of fire, electrical shock, or injury to persons:

- DURING ASSEMBLY BE SURE ALL POWER TO WORKING AREA IS DISABLED
- Use proper tools during installation.
- Do not hang any objects on the lamp e.g. clothing
- 60 W maximum for incandescent light bulbs
- Do not leave any wires exposed.
- Avoid contact with liquids of any kind.

### TABLE OF CONTENTS

 — 2PCS	Wire Nut
 — 2PCS	Canopy Cap
 — 2PCS	Bracket Bolts
 — 1PCS	Mounting Bracket
 — 2PCS	Diffuser Rod
 — 2PCS	Diffuser Cap
 — 1PC	Frosted Glass Diffuser



HOME

# SHARPER IMAGE®

FOR BEST RESULT, HAVE LIGHTING PROFESSIONALLY INSTALLED BY A QUALIFIED LICENSED ELECTRICIAN

Please read carefully and save these instructions, as you may need them at a later date. Turn off the main power at the circuit breaker before installing the fixture, in order to prevent possible shock.

1

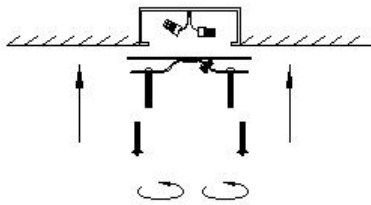

- Use the "Bracket Bolts" provided to attach the "Mounting Bracket" to the electrical junction.

2

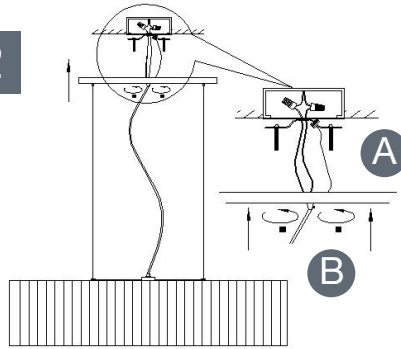

- (A) Connect wires to the electrical socket wires please reference "Wiring Schematic"  
 - (B) Connect assembly to electrical junction using "Canopy Caps".

## Wiring Schematic

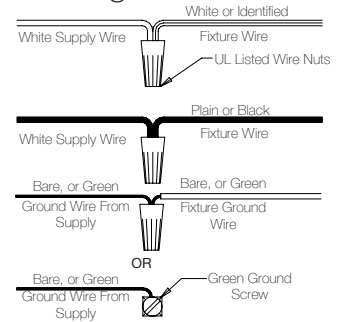

3

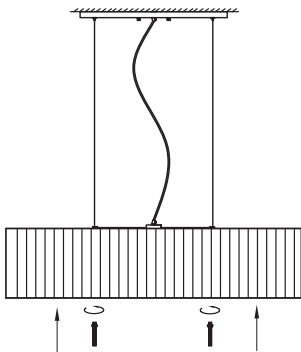

- Attach the "Diffuser Rod" into the shade bracket assembly.

4

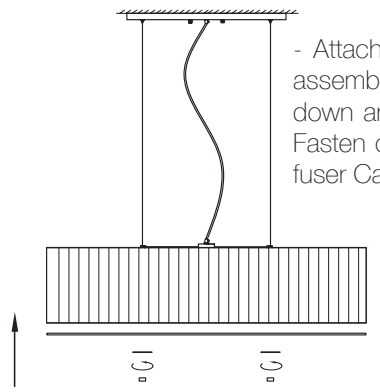

- Attach the "Frosted Glass Diffuser" to the assembly be sure the glossy side is facing down and avoid touching the textured side. Fasten one side of the diffuser with the "Diffuser Cap". Repeat for opposite side.

5

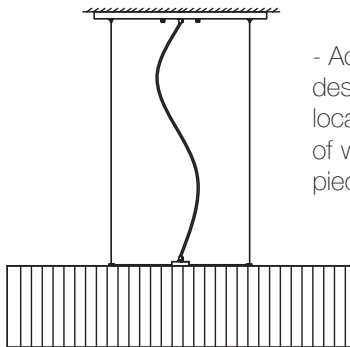

- Adjust the electrical wire of the pendant to your desired specifications and then tighten the screw located above the canopy to maintain position of wire. Inspect entire assembly, and be sure all pieces are securely attached.



This lighting chain contains recyclable materials. Do not dispose product as unsorted municipal waste. Please contact your local municipality for the nearest collection point.

\*Please note that the illustration displayed above is solely based for configuration purposes only and may not depict actual scaled dimensions of contents.



Customer Service  
1-877-762-8662  
8:00 a.m. - 5:00 p.m. (EST)  
Monday - Friday  
Customer service email: [sharperimage@iconintl.net](mailto:sharperimage@iconintl.net)

### THREE YEAR LIMITED WARRANTY

ICON International Inc. sells its products with the intent that they are free of defects in manufacture and workmanship for a period of three years from the date of original purchase, except as noted below. ICON International Inc. warrants that its products will be free of defects in material and workmanship under normal use and service. This warranty extends only to consumers and does not extend to Retailers.

To obtain warranty service on your Sharper Image® product, mail the product and your dated sales receipt (as proof of purchase), postpaid, to the following address:

**Customer Service**  
**Attn: Sharper Image Department**  
**C/O ICON International INC.**  
**500 Callahan Road**  
**North Kingstown, RI 02852**

No COD's will be accepted.

ICON International Inc. does not authorize anyone, including, but not limited to, Retailers, the subsequent consumer purchaser of the product from a Retailer or remote purchasers, to obligate ICON International Inc. in any way beyond the terms set forth herein. This warranty does not cover damage caused by misuse or abuse; accident; the attachment of any unauthorized accessory; alteration to the product; improper installation; unauthorized repairs or modifications; improper use of electrical/power supply; loss of power; dropped product; malfunction or damage of an operating part from failure to provide manufacturer's recommended maintenance; transportation damage; theft; neglect; vandalism; or environmental conditions; loss of use during the period the product is at a repair facility or otherwise awaiting parts or repair; or any other conditions whatsoever that are beyond the control of ICON International Inc.

This warranty is effective only if the product is purchased and operated in the country in which the product is purchased. A product that requires modifications or adoption to enable it to operate in any other country than the country for which it was designed, manufactured, approved and/or authorized, or repair of products damaged by these modifications is not covered under this warranty

THE WARRANTY PROVIDED HEREIN SHALL BE THE SOLE AND EXCLUSIVE WARRANTY. THERE SHALL BE NO OTHER WARRANTIES EXPRESS OR IMPLIED INCLUDING ANY IMPLIED WARRANTY OF MERCHANTABILITY OR FITNESS OR ANY OTHER OBLIGATION ON THE PART OF THE COMPANY WITH RESPECT TO PRODUCTS COVERED BY THIS WARRANTY. ICON International Inc. SHALL HAVE NO LIABILITY FOR INCIDENTAL, CONSEQUENTIAL OR SPECIAL DAMAGES. IN NO EVENT SHALL THIS WARRANTY REQUIRE MORE THAN THE REPAIR OR REPLACEMENT OF ANY PART OR PARTS WHICH ARE FOUND TO BE DEFECTIVE WITHIN THE EFFECTIVE PERIOD OF THE WARRANTY.

NO REFUNDS WILL BE GIVEN. IF REPLACEMENT PARTS FOR DEFECTIVE MATERIALS ARE NOT AVAILABLE, ICON International Inc. RESERVES THE RIGHT TO MAKE PRODUCTS SUBSTITUTIONS IN LIEU OF REPAIR OR REPLACEMENT.

This warranty does not extend to the purchase of opened, used, repaired, repackaged and/or resealed products, including but not limited to sale of such products on Internet auction sites and or sales of such products by surplus or bulk resellers. Any and all warranties or guarantees shall immediately cease and terminate as to any products or parts thereof which are repaired, replaced, altered, or modified, without the prior express and written consent of ICON International Inc..

This warranty provides you with specific legal rights. You may have additional rights which may vary from state to state. Because of individual regulations, some of the above limitations and exclusions may not apply to you. For more information regarding our product line in the USA, please visit: [www.sharperimage.com](http://www.sharperimage.com)

SHARPER IMAGE® name and logo are registered trademarks.  
Manufactured and Marketed by ICON INTERNATIONAL INC. under license.  
©Sharper Image. All Rights Reserved.