

Central Brass

COMPANY

Date: _____

PARTS BREAKDOWN SHEET

SLOW-CLOSE STRAIGHT STOP

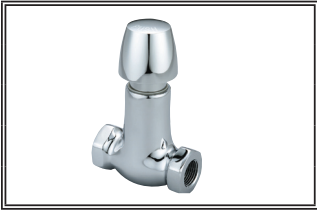

Model #: _____

Specific Features: _____

Project Name: _____

Submitted For: _____

Date: _____

- Slow-Close Straight Stop
- Push Handle

0336-N2-1/2
SHOWN

ADA



Model #	Features	Finish	
0336-N2-1/2	1/2-14 NPS Female Inlet & Outlet	PVD PC	
0336-N2-3/8	3/8-18 NPS Female Inlet & Outlet	PVD PC	

Central Brass products are engineered and manufactured to meet the following standards and codes:

- ASME A112.18.1M
- ANSI A117.1
- ANSI / NSF 61, SECTION 9
- CONTAINS NO MORE THAN 0.25% WEIGHTED AVERAGE LEAD CONTENT

	ITEM #	DESCRIPTION
A	CS-13003P	Plain Push Handle
B	170-WA	3/32" Allen Wrench
C	CS-49016P	Plain Handle Repair Kit
1	X103-HS	Set Screw (6 Pcs Per Pack)
2	X1028-Y	Washer (2 Pcs Per Pack)

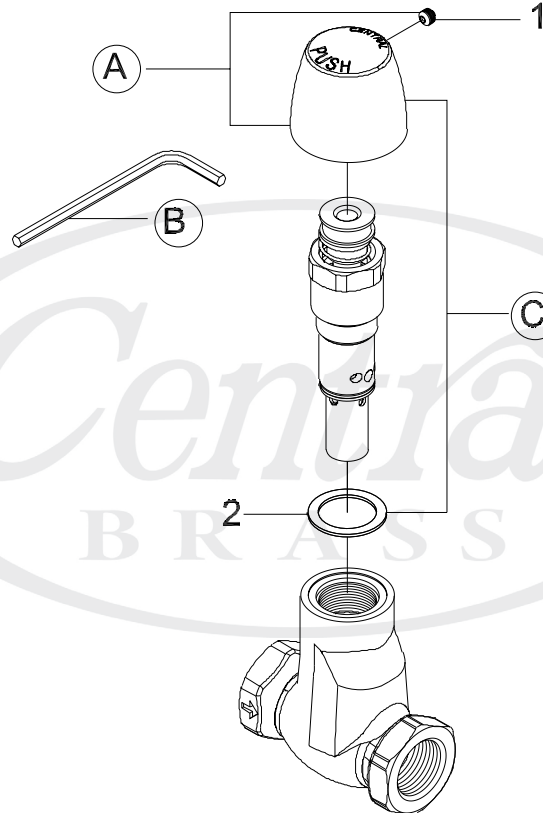

Brecksville, OH
www.centralbrass.com
Central Brass Company © 2011