

# SOHO LATERAL FILE

Installation and use manual for SOHO lateral file

## WARNING

AN IMPROPERLY INSTALLED FILE CABINET CAN BECOME UNSTABLE OR TIP OVER, CAUSING SERIOUS INJURY. FOLLOW ALL INSTRUCTIONS IN THIS MANUAL FOR CORRECT INSTALLATION, USE AND MAINTENANCE.

These files are for storing and filing non-combustible materials that do not require special protection. Do not use this cabinet to store combustible or hazardous materials.

WEAR SAFETY GLASSES WHEN USING TOOLS

### REQUIRED ADJUSTMENTS

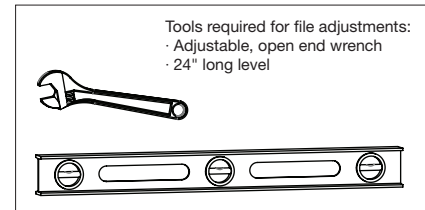

Adjustable glides are provided in the base of each cabinet. Depending on which model you have, your cabinet may have 4 glides (one at each corner) or 2 glides in the front corners of the base. Glide adjustment is critical for cabinet stability and proper operation of lock, interlock, drawers or other moving features that may be present on your cabinet.

1. Be sure cabinet is empty.
2. Place a 24" level across the front of the cabinet to level side-to-side. Adjust the front glides from the outside of the cabinet using an adjustable open end wrench. Turn the glides clockwise to raise the cabinet and counterclockwise to lower the cabinet. It may be necessary to cautiously tip the cabinet back slightly to make the front glide adjustments.
3. The final glide adjustment is to adjust the glides so that the front of the cabinet is higher than the rear while maintaining the side to side levelness.
4. Check cabinet for proper operation. All drawers on your cabinet should open and close smoothly and be evenly aligned with the frame. The glide adjustment and levelness of your cabinet can effect this operation.

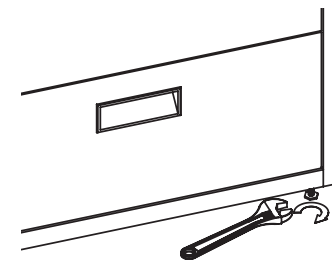

Clockwise to raise

## LOADING AND UNLOADING



### WARNING

An improperly loaded or unloaded file cabinet can become unstable or tip over causing serious injury.

#### Loading:

1. Check cabinet for proper adjustment and stability.
2. Load bottom drawer first to increase stability.
3. Distribute contents and weight evenly among remaining drawers.
4. Check to see if cabinet is stable after loading is complete (on carpeted surfaces, settling may occur). If necessary, empty cabinet completely, then readjust glides.

#### Unloading:

1. Remove contents from top drawer first.
2. Remove contents from bottom drawer last.

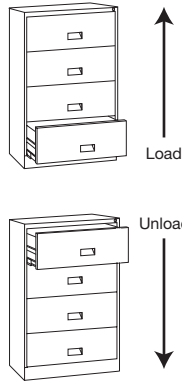

## OPERATING



### WARNING

If misused, this cabinet can become unstable or tip over, causing serious injury. To help prevent accidents, follow instructions below.

- Do not stand or lean on an open drawer.
- Do not put materials on an open drawer. Use table to sort or collate.
- If this cabinet ever seems unstable, do not use it. Have it checked for proper leveling and loading. Have any problems corrected immediately.
- This cabinet has an interlock to prevent opening more than one drawer at a time. Do not try to defeat this interlock.
- These files are for storing and filing non-combustible materials that do not require special protection. Do not use this cabinet to store combustible or hazardous materials.

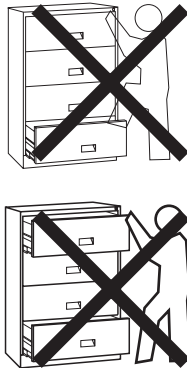

## RELOCATING



### WARNING

If not properly secured when moving, this file cabinet can become unstable or tip over, causing serious injury.

#### Before moving cabinet:

1. Unload contents. (Unload from the top. See loading and unloading above.)
2. Secure the unit:
  - Close and lock the cabinet.
  - Use furniture straps and appropriate moving equipment.
3. After positioning cabinet in new location, follow instructions for adjusting and installing.

## HANG-RAILS FOR HANGING FILE FOLDERS

There are two hang-rails per drawer.

Positions 1 & 2 accommodate letter-size hanging file folders side-to-side.

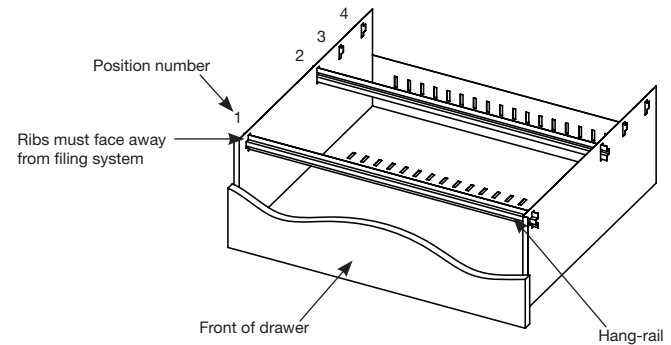

## OPTIONAL FRONT-TO-BACK FILING

1. Hang-rails must be in Positions 1 & 2 as shown.
2. Position front-to-back rails on front and rear hang-rails for each bank of hanging file folders. The side of the drawer should be used for outermost side of hanging file folders.

