

Studio

Pureform™ Bamboo Wide Plank Floating Floor with the Välinge 2G locking system



FINE BAMBOO FLOORING, PANELS & WORKTOPS

Important Product Line Notes:

- Check Teragren.com for the latest updates to our Installation Guidelines
- Teragren wide-plank engineered bamboo flooring is suitable for installation as a floating system above, on, or below grade.
- Flooring must be delivered to the job site a minimum of 48 hours prior to installation. Do not deliver or install flooring until the building has been enclosed with windows and doors, and all cement, plastering, and other “wet” work has been completed.
- Handle and unload flooring with care. Store in a dry place with at least a four-inch air space under cartons. Do not store boxes on uncovered concrete or other cementitious materials.
- The use of Vapor Barriers (over cementitious subfloors) or Vapor Retarders (over wood subfloors) is mandatory.
- Install into environments with HVAC systems able to consistently maintain 35-55% Relative Humidity at 60-80° Fahrenheit.
- Ensure flooring is installed in such a manner to allow for up to 1/2” expansion or 1/2” contraction around walls or any other fixed object.
- Bamboo Flooring may be installed over radiant floor heating systems (see “Radiant Floors” section below). Surface Temperature of flooring must never exceed 85° F.
- Always install transition pieces between rooms etc. to allow unique spaces to expand and contract in an unrestricted manner. NOTE: Do not install cabinets or walls on top of the floating floor.
- Installer to document installation date, product run code (off box ends), flooring moisture content, site relative humidity, site temperature, and subfloor moisture content. This information must be retained by the installer and left with the property owner as a permanent record.

Pre-Installation Notes:

Please read Teragren LLC’s warranty, maintenance instructions, and ALL of the following guidelines before opening any packaging or beginning your flooring installation. All information within this document is provided as a courtesy to our customers and is meant to be understood as an installation guideline only. The customer and/or the installer is solely responsible for any and all decisions regarding how, where, and when to install any Teragren product.

Teragren LLC recommends using the services of a professional hardwood flooring installer. For more information and for guidelines on the installation of hardwood flooring, please contact the National Wood Flooring Association or review their website <http://www.woodfloors.org>.

Because bamboo is a natural fiber, it is not uncommon for natural variations in color to occur within and between individual flooring planks. Teragren’s warranty does not cover variations in color either in individual planks, between the planks, or the variations in color between our product samples and the installed flooring. An industry standard of 5% material overage should be added to the actual square footage required for cutting and grading allowances.

Prior to installation, all material must be inspected to ensure the material received matches the work order. Any visible defects or discrepancies must immediately be reported to your distributor or dealer. It is considered the installer/owner’s responsibility not to install flooring having finish, manufacturing, or unacceptable material variations. Individual planks with defects must not be installed or the defect must be cut-out prior to installation. Filler or putty stick may be used to correct minor flooring defects during installation. The Teragren warranty does not cover materials with visible defects once they are installed.

It is the sole responsibility of the installer/owner to determine if the job site’s sub-floor and environmental conditions are suitable for the installation of Teragren flooring and accessories. Teragren LLC makes no warranty or guarantee of the quality of the chosen installer’s work or of a particular installation performed by the installer. Teragren LLC disclaims all liability for any errors or improprieties in the installation of its products. Installation of any Teragren product serves as acceptance of that material.

Product Acclimation

Teragren bamboo flooring must be installed over a vapor barrier or vapor retarder into environments with HVAC systems able to consistently maintain 35-55% Relative Humidity at 60-80° Fahrenheit. Climate conditions (RH Conditions) outside of the recommended range will cause the moisture of the flooring to decrease or increase and may cause excessive shrinking, swelling, checking, cupping, buckling, or other unintended dimensional change. For proper acclimation, flooring must be delivered to the job site a minimum of 48 hours prior to installation. Evenly distribute unopened boxes in a dry space leaving at least a four-inch air space under the cartons to ensure all boxes can acclimate to job site temperature. Do not store boxes on uncovered concrete or other cementitious materials.

Installation Method(s):

Bamboo Flooring must be installed into a relative humidity controlled environment over a vapor barrier or vapor retarder per the following specifications:

- **Concrete Subfloors:** Use an appropriate liquid or trowel-applied vapor barrier membrane/adhesive system. Impermeable vapor barrier systems with a perm rating less than or equal to .13 are suggested.
- **Wood Subfloors:** Use a UU-B-790a, Grade B, Type 1, Style 1a permeable vapor retarder or equivalent with a perm rating between .7 and 1
- **NOTE:** Flooring must be installed in such a manner to allow for up to 1/2" expansion and 1/2" contraction of your installed flooring. Bamboo, like all hardwoods, expands and contracts as its moisture content rises and falls.
- Use a combination of wall moldings such as a base-molding and base-shoe together to ensure that the edge of the installed flooring does not strike the wall if it expands and does not show if the flooring shrinks.

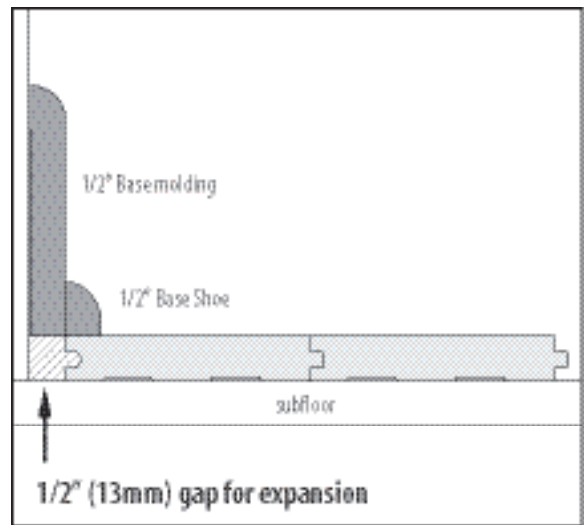

Teragren bamboo flooring is best installed by one of the following methods:

- **Above, on, or below grade:** Flooring must be installed by floating planks over a wooden or concrete subfloor

Tools Recommended (not all tools may be required):

Rubber mallet, tapping block (tested to ensure it won't damage planks), tape measure, chalk line, pencil, carpenter square, scribing block, flat bar, 1/2" (13mm) wedges, saw, chop saw, vapor barrier (for crawl spaces), vapor barrier or vapor retarder (depending on subfloor material), underlayment (floating floor approved underlayment or cork not exceeding 5/64" (2mm) in thickness may be used).

Sub-Floor Examination and Preparation:

A vapor barrier such as 6 mil polyethylene film must be placed in crawl spaces. Wood sub-flooring surfaces must have no flex and must be smooth, level, clean, dry, and free of contaminants. Fix any squeaks or movement in the sub-floor prior to installation. High spots must be sanded flat. Any low spots equal to or greater than 5/64" (2mm) over 78" (1.98 meter) must be filled (brought to level) using a non-compressible material. Suitable surfaces may include concrete, particleboard, wood floors, and both ceramic and vinyl tiles, among others. Please consult with your professional flooring installer to determine suitability of sub-floor surface. Acceptable sub-floor specifications include 5/8" (16mm) T&G CD Exposure 1 plywood for 12" (30.5cm) and 16" (41cm) on center floors (OC), 3/4" (19mm) T&G CD Exposure 1 plywood for 16" (40.6cm) to 19" (48.3cm) OC floors, and 7/8" (22mm) T&G CD Exposure 1 plywood for 24" (61cm) OC floors. A sub-floor of 1-1/8" (28.5mm) plywood over joists at 16" (40.6cm) on center is recommended for an optimal installation. Note: the use of particleboard may result in a substandard subfloor due to the lack of rigidity.

Concrete sub-floors MUST be tested for moisture in more than one place for consistent readings. Teragren recommends using a Calcium Chloride Test Method to quantify the volume of moisture vapor radiating from a concrete slab surface over time and / or a Relative Humidity Probe test to quantify the amount of relative humidity within the slab. The use of a Vapor Barrier (over cementitious materials) or a Vapor Retarder (over wood) is mandatory.

Floating Floor Installation:

Install a vapor barrier or vapor retarder over the entire subfloor surface following closely the manufacturer's recommendations. Next, roll out 5/64" (2mm) padding (underlayment) one roll at a time over the vapor barrier or vapor retarder, being careful not to poke holes through or damage either material during installation. Run padding up walls 1" to 1-1/2" (25.4 to 38.1mm) and secure in place with tape. Join padding sections to one-another with tape. Make sure to tape down all loose edges. Other approved floating floor underlayment materials such as cork may be used. Follow underlayment manufacturer's installation instructions. Note: flexible underlayment must not exceed 5/64" (2mm) in thickness.

Note: The use of an underlayment or padding thicker than 5/64" (2mm) may result in plank movement causing damage to the flooring and/or friction induced noise such as "creaking" or "squeaking".

Measure the room so that the quantity of flooring required is known (length x width = square feet). If the last board required is too narrow in width, it may be necessary to install length-wise cut boards on both sides of the room to give it an overall balanced look. Ensure that the floor will fit under doors and skirting strips. Existing skirting strips may have to be removed during installation to allow for the expansion perimeter. Ideally, the flooring should be installed parallel to the longest dimension of the room. In a square room, the long joints should (preferably), follow the path of the incoming light. Allow for a minimum expansion space of 1/2" (13mm) around the perimeter of the installed flooring. For floors larger than 16' (4.87 meter) in any one direction, leave an additional expansion space of 1/8" (3.2mm) on the edges for each 48" (1.2 meter) of installed flooring. For example, a 24' (7.3 meter) square room would require about 3/4" (19mm) expansion on all sides. Rooms larger than 40' (12.2 meters) wide (boards running length of room) require an expansion joint in the middle of the room such as could be provided by leaving an intentional gap covered by a t-mold (or other flat molding) or other accessory piece. Any rooms that are not square (such as a T, L, F, or U shaped room) must have non-parallel areas separated by an expansion joint. All door opening must have an expansion joint between rooms. Under no circumstances should the floor's ability to move freely be restricted.

First Row:

Groove End / Tongue End

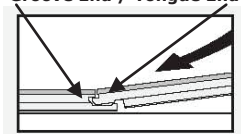

Start in a corner of the room with the locking strip (groove end) facing the room (see picture #1). Using spacer wedges as required, maintain a 1/2" gap between the wall and the planks being installed. Install the first plank. Install the second plank (see picture #2), pressing the end of the second floorboard in at an angle to the first one and then laying it down flat on the ground to engage the locking mechanism. Continue with this method until you are ready to install the last plank of the first row. Cut the last plank of the first row to size using a rotary saw with a carbide blade then install as done for the previous planks, leaving a 1/2" gap at the end. After the first row is complete, ensure that all edges are even and parallel. Note: It is practical to fine-tune the gap between the long sides and the wall later, after the first three rows have been laid.

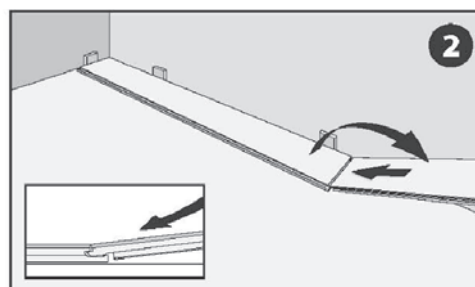
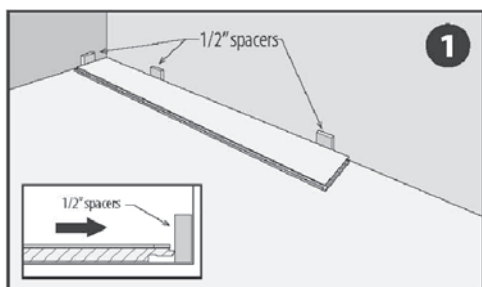

Second Row:

Start the second row beginning with (if available) the piece left over (cut off) from the first row (piece must be at least 20" in length). If the piece is too short (or if there is no leftover piece), start with a new board, cut in half. Always ensure that the end joints are staggered at least 20 inches. Maintaining a 1/2" gap between the end of plank and the wall, insert the long edge of the plank into the adjacent plank of the first row (see picture #3). Push forward and press down at the same time to fully engage the locking mechanism. With the plank resting flat on the floor, ensure there is no gapping on any of the joints. Next, lift the end of the plank and rest it on an installation wedge so that it is not lying flat on the floor (see picture #3). Insert the end of the next plank (see picture #4) into the end of the previously installed plank, lowering the plank until it is parallel to the ground with the long edge of the plank resting on the edge of the first row's locking mechanism. Rest the end of this plank on an installation wedge so that the entire edge of the plank is at the same angle as the end of the first plank.

INSTALLATION GUIDELINES/Studio

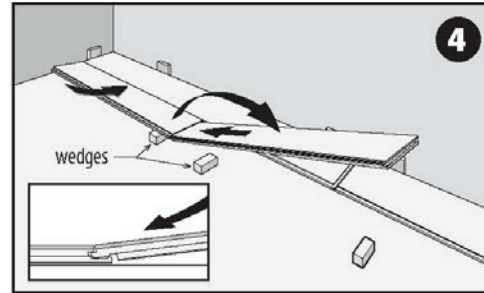
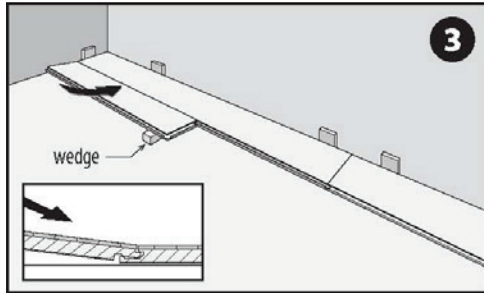

Slowly and evenly push the entire length (the long edge) of the second planks' locking mechanism fully into place using a tapping block if required (see picture #5). Once completely inserted, remove all wedges and press the entire plank down to lock the plank. Use a rubber mallet and a tapping block to ensure all edges are perfectly mated. Lift up the very end of the newly installed plank and place an installation wedge underneath it in preparation for installation of the next plank. Continue to install the whole row (see picture#6).

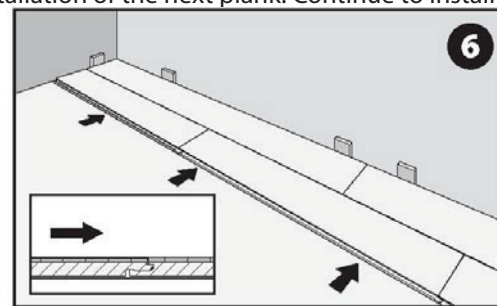
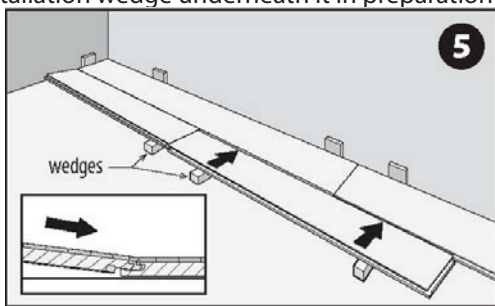

When the entire row is completed, remove all wedges and review the row to ensure there is no gapping and that all locking mechanisms are fully engaged (all planks are perfectly flat). Note: Never hammer planks without using a tapping block or damage to plank edges will occur.

Installation around pipes or columns:

Drill holes and saw out flooring as required to make room for any exposed structure or pipe. Note: holes around pipes or other items must be at least 3/4" greater in diameter than the pipe or structure.

Installation with Transition pieces:

Flooring must be allowed to float freely underneath the overlap portion of the transition piece. To ensure freedom of movement, cut or chisel off tongue as required to allow unrestricted movement of the flooring under the transition piece.

Radiant Heat:

Teragren bamboo flooring is suitable for installation over radiant heating systems capable of maintaining a surface temperature at or below 85°F. When choosing an installer for application over radiant heat, look for members of the Radiant Panel Association. Please refer to www.radiantpanelassociation.org for more information on radiant heat systems.

Rugs placed on a floor heated by a radiant source can increase the surface temperature of that floor by 2-3 degrees Fahrenheit. If using an adhesive to "glue-down" bamboo flooring, please confirm with the adhesive manufacturer the suitability of the adhesive for use with radiant heating systems. Before installing the flooring, activate the radiant heating system and leave it on for at least 21 days prior to installation. Radiant heating systems must be turned off 24 hours prior to and during flooring installation. If no adhesive has been used, the radiant heating system may be reactivated after the flooring installation is complete. If adhesive has been used, follow the adhesive manufacturer's guidelines regarding adhesive cure time before reactivating the radiant heating system.

It is up to the owner/installer to confirm the suitability of any radiant-heating system for the intended end-use. The selection and use of any radiant heating system is at the sole discretion and responsibility of the owner/installer.

INSTALLATION GUIDELINES/Studio

Maintenance Guidelines:

Teragren recommends vacuuming or sweeping in order to remove dirt and grit prior to cleaning the flooring. Remove any liquid spills promptly. Exposure to the sun and ultra-violet light can accelerate oxidation (color- change). Periodically rearrange rugs and furniture to allow for consistent aging of the flooring. Use area rugs in high traffic areas. Install wood guards on the feet or legs of furniture.

Do not use wax, oil soap or other household cleaners. Teragren recommends using either *WoodWise Floor Cleaner* by [Design Hardwood Products](#) (800.424.7092), or *Bona Swedish Formula® MicroPlus Hardwood Floor Cleaner* by [BonaKemi USA, Inc.](#) (800.574.4674).

Proper care and maintenance can extend the life of your floor for many years; however, at some time a re-coat or total refinishing may be desirable. To re-coat your floor and remain in conformance with the Teragren warranty, follow the manufacturer's instructions at either of the following:

[Basic Coatings](#) *Tykote Sandless Re-coating System* (800.441.1934) or *BonaPrep™ Re-coating Adhesion System* by [BonaKemi USA](#) (800.872.5515).

Contact your Teragren distributor or retailer for more information or [email tech support](#).

