

TECHNICAL SPECIFICATIONS

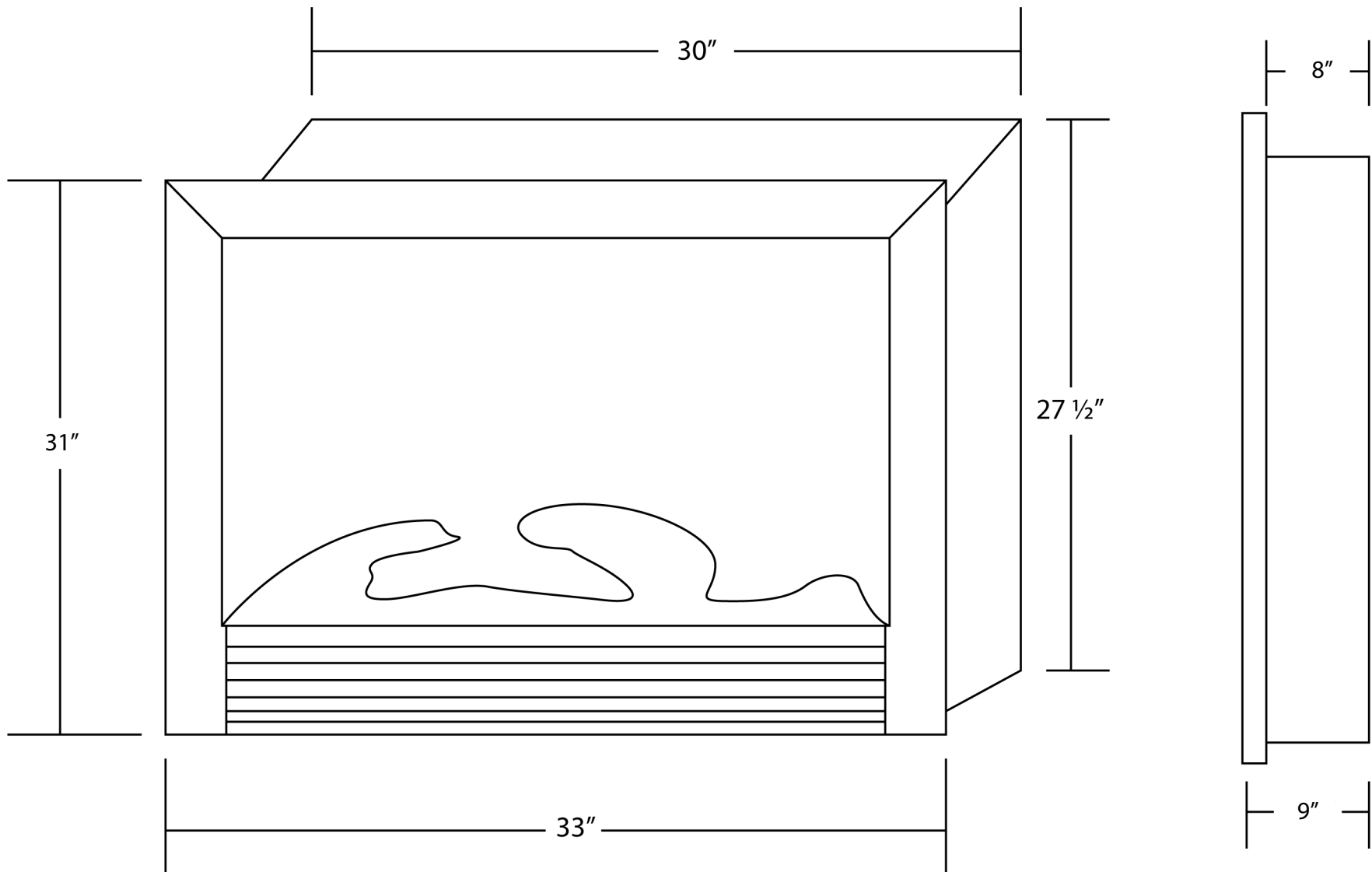

MODEL NUMBER	DF-EFP765
VOLTS	120
AMPS	13.50
RATED POWER WATTS	1,625
HEATER	HIGH LOW
	1,500 watts 750 watts
NO HEATER	125 watts
LAMPS	QUANTITY WATTS TOTAL WATTS
	3 Candelabra Incandescent 40 watts 120 watts
ROTOR MOTOR	1 at 5 watts
HEAT ENERGY	5000 BTU
DIMENSION	33"W x 31" H x 8" D
SHIPPING SIZE	35 1/2" x 32 3/4" x 13 1/4"
WEIGHT	GROSS NET
	59 lbs. 54 lbs.
PLUG LOCATION	Bottom right
CONTROL BUTTONS LOCATION	Bottom right corner behind the front grill
CORD LENGTH	67"
APPROX. HEATING AREA	220 sq. ft.



YOSEMITE
HOME DÉCOR

SERIES INSERTS	MODEL NAME TRITON
-------------------	----------------------