



TRANSPORT CHAIRS

OPERATORS MANUAL

MODEL NO. **9200**-----17" BURGUNDY PROBASICS LIGHTWEIGHT ALUMINUM
TRANSPORT CHAIR

MODEL NO. **9200GR**-----17" GREEN PROBASICS LIGHTWEIGHT ALUMINUM
TRANSPORT CHAIR

MODEL NO. **9200BL** -----17" BLUE PROBASICS LIGHTWEIGHT ALUMINUM
TRANSPORT CHAIR

MODEL NO. **9200BK**-----17" BLACK PROBASICS LIGHTWEIGHT ALUMINUM
TRANSPORT CHAIR

MODEL NO. **9201**-----19" BURGUNDY PROBASICS LIGHTWEIGHT ALUMINUM
TRANSPORT CHAIR

MODEL NO. **9201BL**-----19" BLUE PROBASICS LIGHTWEIGHT ALUMINUM
TRANSPORT CHAIR

MODEL NO. **9201GR**-----19" GREEN PROBASICS LIGHTWEIGHT ALUMINUM
TRANSPORT CHAIR

MODEL NO. **9201S**-----19" SILVER PROBASICS LIGHTWEIGHT ALUMINUM
TRANSPORT CHAIR

MODEL NO. **9201BK**-----19" BLACK PROBASICS LIGHTWEIGHT ALUMINUM
TRANSPORT CHAIR

MODEL NO. **9300BK**-----21" BLACK PROBASICS LIGHTWEIGHT ALUMINUM
TRANSPORT CHAIR

MODEL NO. **9300**-----21" BURGUNDY PROBASICS LIGHTWEIGHT ALUMINUM
TRANSPORT CHAIR

MODEL NO. **9600GRVP**-----19" GREY PLAID UPHOLSTERY PROBASICS
LIGHTWEIGHT ALUMINUM TRANSPORT CHAIR

MODEL NO. **9600GRNP**-----19" GREEN PLAIN UPHOLSTERY PROBASICS
LIGHTWEIGHT ALUMINUM TRANSPORT CHAIR

MODEL NO. **9400**----BURGUNDY 19" LIGHTWEIGHT ALUMINUM TRANSPORT
CHAIR W/REAR CABLE HAND BRAKES

MODEL NO. **9400BK**---BLACK 19" LIGHTWEIGHT ALUMINUM TRANSPORT CHAIR
W/REAR CABLE HAND BRAKES

MODEL NO. **9500**---BURGUNDY 22"HEAVY DUTY TRANSPORT CHAIR
MODEL NO. **9500BK**---BLACK 22"HEAVY DUTY TRANSPORT CHAIR

MODEL NO. **9015**---TRANSPORT CHAIR W/ 19" SEAT WIDTH
MODEL NO. **0005**---TRANSPORT CHAIR W/ 17" SEAT WIDTH

PROBASICS LIGHTWEIGHT ALUMINUM TRANSPORT CHAIR 19"LIGHTWEIGHT ALUMINUM TRANSPORT CHAIR W/REAR CABLE



22"HEAVY DUTY TRANSPORT CHAIR (BARIATRIC)



TRANSPORT CHAIR W/19" SEAT WIDTH



NOTE: Check ALL parts for shipping damage before use. In case of shipping damage, DO NOT use. Contact Carrier/Dealer for further instruction.

Index

1. General Guidelines.....	4
2. Operating Information.....	6
3. Weight Training	8
4. Weight Limitations	8
5. Safety/Handling of Wheelchairs	8
6. Stability and Balance	9
7. Coping w/Everyday Obstacles	10
8. A Note to Wheelchair Assistants	10
9. Percentage of Weight Distribution.....	11
10. Reaching, Leaning and Bending Forward.....	11
11. Reaching, Leaning Backwards.....	12
12. Tipping.....	12
13. Stairways	13
14. Folding and Unfolding Wheelchair	14
15. Safety Inspection.....	15
16. Safety Inspection Checklist	15
17. Inspect/Adjust Initially	15
18. Inspect/Adjust Weekly	16
19. Inspect/Adjust Monthly	16
20. Inspect/Adjust Periodically	17
21. Maintenance	17
22. Suggested Maintenance Procedures	18
23. Front Rigging.....	18
24. Installing Swingaway Footrest Assembly	19
25. Adjusting Footplate Height	19
26. Back.....	20

27. Unfolding/Folding the Fold-down Back	20
28. Replacing Back Upholstery	21
29. Replacing Seat Upholstery.....	22
30. Rear Wheels.....	22
31. Removing/Installing Rear Wheels	22
32. Casters	23
33. Replacing Adjusting Front Folks.....	23
34. Replacing Front Caster	24
35. Hand Brakes/Wheel Locks	24
36. Locking/Unlocking/Using Hand Brakes	24
37. Adjusting Cable Adjuster Unit.....	25
38. Adjusting Wheel Lock.....	26
39. Limited Lifetime Warranty.....	26

GENERAL GUIDLINES

Brakes
must be
locked
before
using seat

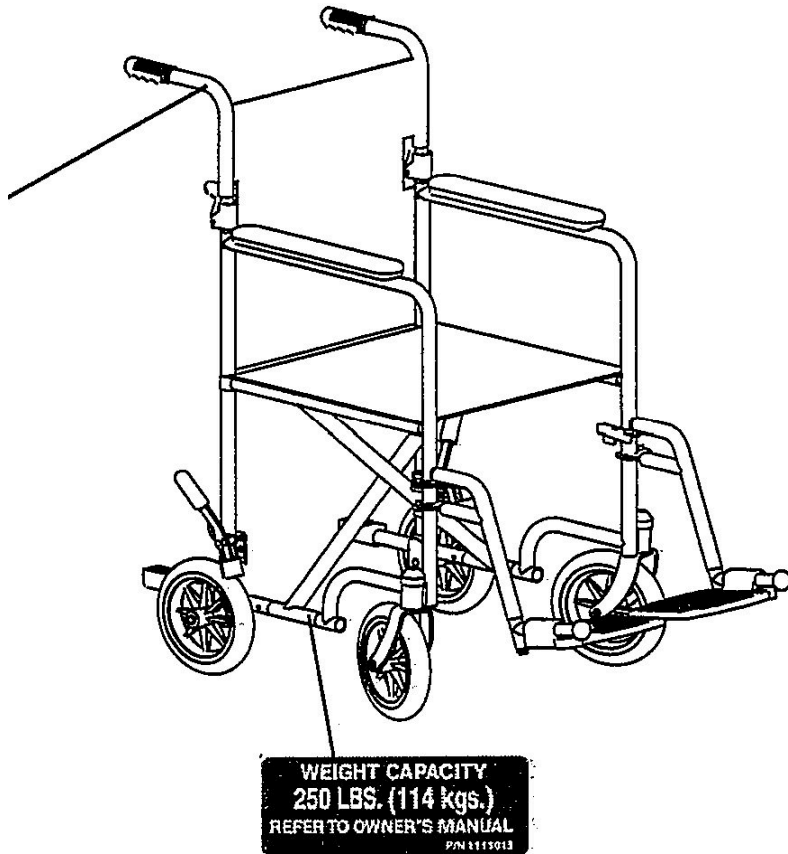

View From Back of Chair

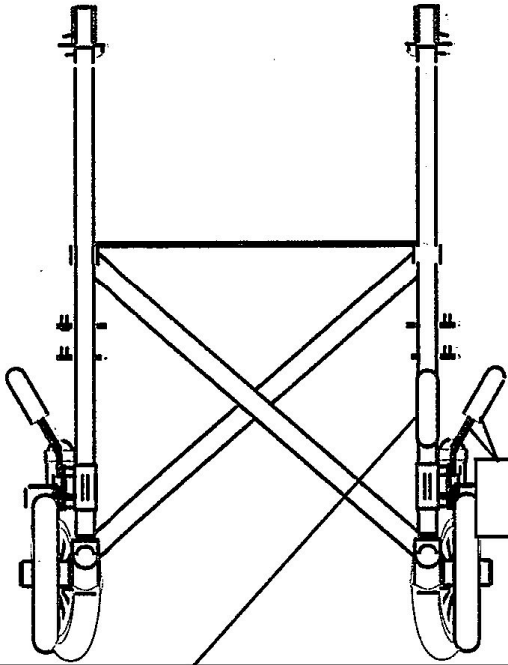

The wheel locks on this transport chair have been preset at the factory to comply with the Veterans Administration functional Standards.

No Transport Chair has been approved for use as a seating surface inside a motor vehicle. This label is for informational purposes only. Liability issues were not considered in the attachment of this label

▲ CAUTION

Any wheel lock adjustments should embed wheel lock shoe at least 1/8" into tire when locked (3/16" on pneumatic tires).

INSTRUCTIONS FOR WHEEL LOCK ADJUSTMENTS

1. Loosen wheel lock mounting fastener, which runs through mounting bracket and frame.
2. Slide clamp toward rear wheel until wheel lock shoe is embedded into tire material at least 1/8" when handle is engaged to the lock position (3/16" for pneumatic tires).
3. Tighten mounting fastener to secure mounting bracket in desired location and recheck lock shoe embedding.
4. Inspect for correct locking action BEFORE actual use.

P/N 1143193 REV A

⚠ WARNING
DO NOT leave the Bariatric Transport on inclined surfaces. The wheel locks and hand brakes may not hold the Bariatric Transport on inclined surfaces due to the transport chair's increased weight capacity.
1130284 Rev B - 4/24/06

WARNING	MISE EN GARDE
BRAKES MUST BE LOCKED BEFORE USING SEAT 1076214	BLOQUER LES FREINS AVANT D'UTILISER LE SIEGE

WEIGHT CAPACITY
400 LBS. (182 kgs.)
REFER TO OWNER'S MANUAL
PM 1111213

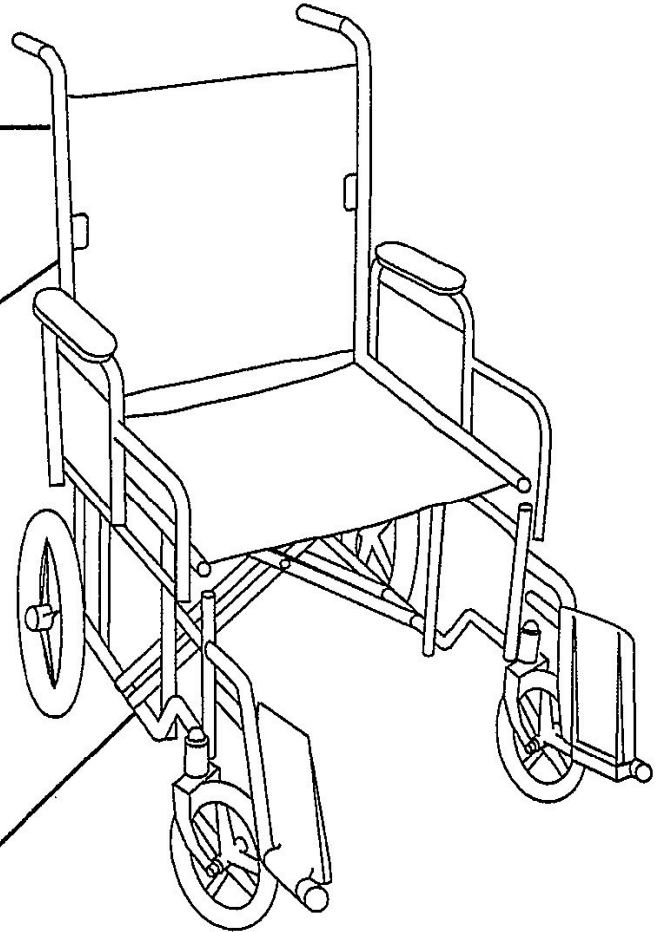

OPERATING INFORMATION

To determine and establish your particular safety limits, practice bending, reaching and transferring activities in several combinations in the presence of a qualified health professional BEFORE attempting active use of the wheelchair.

Make sure the back is locked securely BEFORE using this wheelchair.

ALWAYS verify that the hand grips on the rear cane are secure prior to use when an assistant is used to propel the chair.

DO NOT attempt to reach objects if you have to move forward in the seat.

DO NOT attempt to reach objects if you have to pick them up from the floor by reaching down between your knees.

DO NOT lean over the top of the back upholstery. This will change your center of gravity and may cause you to tip over.

DO NOT shift your weight or sitting position toward the direction you are reaching as the wheelchair may tip over.

DO NOT tilt the wheelchair without assistance.

DO NOT use an escalator to move a wheelchair between floors. Serious bodily injury may occur.

DO NOT leave the Bariatric Transport on inclined surfaces. The wheel locks and hand brakes may not hold the Bariatric Transport on inclined surfaces due to the wheelchair's increased weight capacity.

Wheel locks are NOT brakes. DO NOT attempt to stop a moving wheelchair with the wheel locks.

Before attempting to transfer in or out of the wheelchair, every precaution should be taken to reduce the gap distance. Turn both casters parallel to the object you are transferring onto. When transferring to and from the wheelchair, ALWAYS ENGAGE BOTH WHEEL LOCKS. If the wheelchair is equipped with hand brakes, ALWAYS LOCK BOTH HAND BRAKES before transferring to and from the wheelchair.

DO NOT sit or transfer into the wheelchair unless it is fully open.

DO NOT operate on roads, streets or highways.

DO NOT climb, go up or down ramps or traverse slopes greater than 9 degrees.

DO NOT attempt to move up or down an incline with a water, ice or oil film.

DO NOT attempt to ride over curbs or obstacles. Doing so may cause your wheelchair to tip over and cause bodily harm or damage to the wheelchair.

Probasics products are specifically designed and manufactured for use in conjunction with Probasics accessories. Accessories designed by other manufacturers have not been tested by Probasics and are not recommended for use with Probasics products.

DO NOT over tighten hardware attaching to the frame. This could cause damage to the frame tubing.

Keep hands and fingers clear of moving parts to avoid injury.

DO NOT use the footplate as a platform when getting in or out of the wheelchair.

ALWAYS wear your seat-positioning strap. Inasmuch as the seat positioning strap is an option on the Probasics Transport and the Lightweight Transport (you can order these wheelchairs with or without the seat positioning strap), Probasics strongly recommends ordering the seat-positioning strap as an additional safeguard.

The seat-positioning strap is a positioning belt only. It is not designed for use as a safety device withstanding high stress loads such as auto or aircraft safety belts. If signs of wear appear, the belt MUST be replaced immediately.

DO NOT attempt to lift the wheelchair by any removable (detachable) parts. Lifting by means of any removable (detachable) parts of a wheelchair may result in injury to the user or damage to the wheelchair.

DO NOT stand on the frame of the wheelchair.

WEIGHT TRAINING

Probasics DOES NOT recommend the use of its wheelchairs as a weight training apparatus. Probasics wheelchairs have NOT been designed or tested as a seat for any kind of weight training. If occupant uses said wheelchair as a weight training apparatus, PROBASICS SHALL NOT BE LIABLE FOR BODILY INJURY AND THE WARRANTY WILL BE VOID.

WEIGHT LIMITATIONS

The following are the weight limitations for the Invacare transports:

TRANSPORT WEIGHT LIMITATION (LBS)

Transport -----250 lbs
Lightweight Transport ----- 250 lbs
Bariatric Transport ----- 400 lbs
Lite Transport -----250 lbs

SAFETY/HANDLING OF WHEELCHAIRS

Safety and handling of the wheelchair requires the close attention of the wheelchair user as well as the assistant. This manual points out the most common procedures and

techniques involved in the safe operation and maintenance of the wheelchair. It is important to practice and master these safe techniques until you are comfortable in maneuvering around the frequently encountered architectural barriers.

Use this information only as a basic guide. The techniques that are discussed on the following pages have been used successfully by many.

Individual wheelchair users often develop skills to deal with daily living activities that may differ from those described in this manual. Probasics recognizes and encourages each individual to try what works best for him/her in overcoming architectural obstacles that they may encounter. However, all warnings and cautions given in this manual **MUST** be followed. Techniques in this manual are a starting point for the new wheelchair user and assistant with safety as the most important consideration for all.

Stability and Balance

WARNING

ALWAYS wear your seat-positioning strap. Inasmuch as the seat-positioning strap is an option on the Probasics Transport (you can order this wheelchair with or without the seat positioning strap), Probasics strongly recommends ordering the seat-positioning strap as an additional safeguard. The seat-positioning strap is a positioning belt only. It is not designed for use as a safety device withstanding high stress loads such as auto or aircraft safety belts. If signs of wear appear, the belt must be replaced immediately.

To assure stability and proper operation of your wheelchair, you must at all times maintain proper balance. Your wheelchair has been designed to remain upright and stable during normal daily activities as long as you do not move beyond the center of gravity.

Virtually all activities which involve movement in the wheelchair have an effect on the center of gravity. Probasics recommends using seat/chest positioning straps for additional safety while involved in activities that shift your weight.

DO NOT lean forward out of the wheelchair any further than the length of the armrests. Make sure the casters are pointing in the forward position whenever you lean forward. This can be achieved by advancing the wheelchair and then reversing it in a straight line.

Coping With Everyday Obstacles

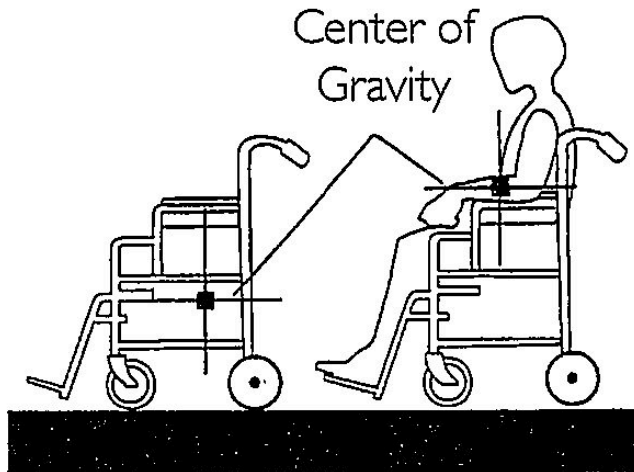

Coping with the irritation of everyday obstacles can be alleviated somewhat by learning how to manage your wheelchair. Keep in mind your center of gravity to maintain stability and balance.

A Note to Wheelchair Assistants

When assistance to the wheelchair user is required, remember to use good body mechanics. Keep your back straight and bend your knees whenever tipping the wheelchair or traversing curbs, or other impediments.

WARNING

DO NOT attempt to lift the wheelchair by any removable (detachable) parts. Lifting by means of any removable (detachable) parts of a wheelchair may result in injury to the user or damage to the wheelchair.

Always verify that hand grips on the rear cane are secure PRIOR to use when an assistant is used to propel or lift the chair. Check for any signs of looseness or deterioration and if found, contact a qualified technician. DO NOT attempt to move the wheelchair by pulling on the handgrips if they are found to be unsecure or have deteriorated.

Also, be aware of detachable parts such as armrests or leg rests. These must NEVER be

used to move the wheelchair or as lifting supports, as they may be inadvertently released, resulting in possible injury to the user and/or assistant(s).

When learning a new assistance technique, have an experienced assistant help you before attempting it alone.

Percentage of Weight Distribution

WARNING

Many activities require the wheelchair owner to reach, bend and transfer in and out of the wheelchair. These movements will cause a change to the normal balance, the center of gravity, and the weight distribution of the wheelchair. To determine and establish your particular safety limits, practice bending, reaching and transferring activities in several combinations in the presence of a qualified healthcare professional **BEFORE** attempting active use of the wheelchair.

Proper positioning is essential for your safety. When reaching, leaning, or bending forward, it is important to use the front casters as a tool to maintain stability and balance.

Reaching, Leaning and Bending Forward

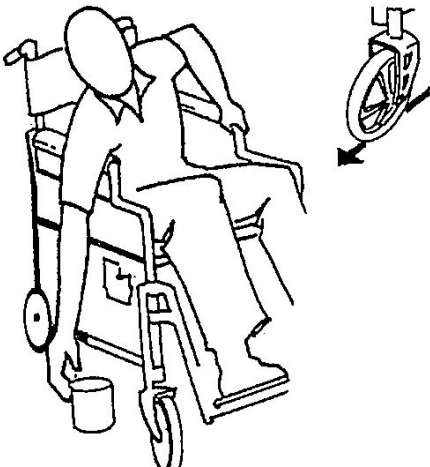

Position the front casters so that they are extended as far forward as possible and lock the hand brakes.

WARNING

DO NOT attempt to reach objects if you have to move forward in the seat or pick them up from the floor by reaching down between your knees.

Reaching, Leaning Backwards

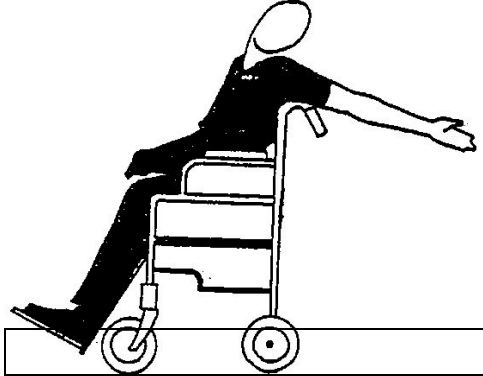

WARNING

DO NOT lean over the top of the back upholstery. This will change your center of gravity and may cause you to tip over.

Position wheelchair as close as possible to the desired object. Point front casters forward to create the longest possible wheelbase. Reach back only as far as your arm will extend without changing your sitting position.

Tipping

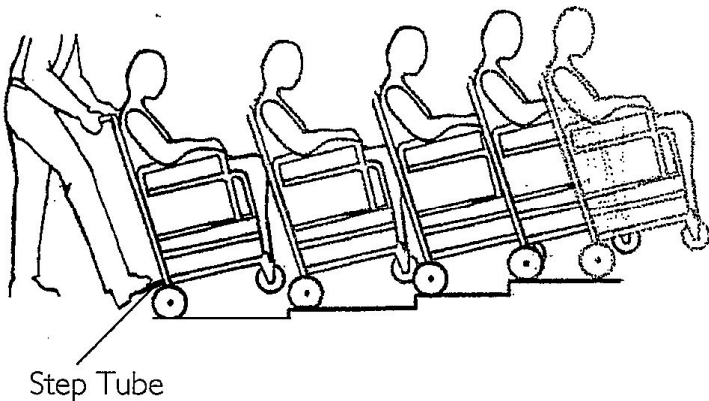

WARNING

DO NOT tip the wheelchair without assistance.

When tipping the wheelchair, an assistant should grasp the back of the wheelchair on a non-removable (non-detachable) part. Inform the wheelchair occupant before tipping the

wheelchair and remind him/her to lean back. Be sure the occupant's feet and hands are clear of all wheels and/or pinch points.

After mastering the techniques of tipping the wheelchair, use the following method to tackle curbs, short stairs, etc.

Place a foot on the step tube and begin to tilt the wheelchair toward you. Apply a continuous downward motion until the balance point is achieved and the front casters clear the curb. At this point, the assistant will feel a difference in the weight distribution

WARNING

When lowering the front casters of the wheelchair, DO NOT let the wheelchair drop the last few inches to the ground. This could result in injury to the occupant and/or damage to the wheelchair.

Roll the wheelchair forward and slowly lower the front of the wheelchair in one continuous movement onto the sidewalk. Push the wheelchair forward until the rear wheels roll up and over the curb.

Stairways

WARNING

ALWAYS wear your seat-positioning strap. Inasmuch as the seat-positioning strap is an option on the Probasics Transport and the Lightweight Transport (you can order these wheelchairs with or without the seat positioning strap), Probasics strongly recommends ordering the seat-positioning strap as an additional safeguard.

The seat-positioning strap is a positioning belt only. It is not designed for use as a safety device withstanding high stress loads such as auto or aircraft safety belts. If

signs of wear appear, the belt must be replaced immediately.

DO NOT attempt to lift a wheelchair by lifting on any removable (detachable) parts. Lifting by means of any removable (detachable) parts of a wheelchair may result in injury to the user or damage to the wheelchair.

Always verify that hand grips on the rear cane are secure prior to use when an assistant is used to propel or lift the chair. Check for any signs of looseness or deterioration and if found, contact a qualified technician. DO NOT attempt to move the wheelchair by pulling on the handgrips if they are found to be unsecure or have deteriorated.

Extreme caution is advised when it is necessary to move an occupied wheelchair up or down the stairs. Probasics recommends that, if possible, the user be removed from the wheelchair prior to moving. Probasics recommends using two (2) assistants and making thorough preparations. Make sure to use ONLY secure, non-detachable parts for hand-held supports.

Follow this procedure for moving the wheelchair between floors when an elevator is NOT available:

1. After the wheelchair has been tilted back to the balance point, one assistant (in the rear) backs the wheelchair up against the first step, while securely grasping a non-removable (non-detachable) part of the wheelchair for leverage.
2. The second assistant, with a firm hold on a non-detachable part of the framework, lifts the wheelchair up and over the stair and steadies the wheelchair as the first assistant places one (1) foot on the next stair and repeats STEP 1.
3. The wheelchair should not be lowered until the last stair has been negotiated and the wheelchair has been rolled away from the stairway.

WARNING

DO NOT use an escalator to move a wheelchair between floors. Serious bodily injury may occur.

Folding and Unfolding Wheelchair

Unfolding

1. Open the wheelchair by grasping the push handle of the wheelchair closest to you.
2. Tilt the wheelchair toward you (raising the opposite wheel and caster off the ground/floor).
3. Push downward on the top of the seat rail closest to you where the seat upholstery is attached until the wheelchair is fully open.

Folding

WARNING

ALWAYS use the straps on the seat rails when folding the wheelchair. Otherwise, hands and fingers may become pinched between the seat rail and the armrest and injury may occur.

-
1. Swing the footrest/leg rest in locked position to the front of the wheelchair.
 2. Pivot the footplates upward to vertical position.
 3. Grasp the two (2) straps on the seat rails and pull up to begin closing the wheelchair.
 4. Continue to close the wheelchair by grasping the armrest furthest from you and pulling the armrest toward you.

SAFETY INSPECTION

NOTE: Every six (6) months take your wheelchair to a qualified technician for a thorough inspection and servicing. Regular cleaning will reveal loose or worn parts and enhance the smooth operation of your wheelchair. To operate properly and safely, your wheelchair must be cared for just like any other vehicle. Routine maintenance will extend the life and efficiency of your wheelchair.

Safety Inspection Checklists

Initial adjustments should be made to suit your personal body structure and preference. Thereafter follow these maintenance procedures:

Inspect/Adjust Initially

- _ Ensure wheelchair rolls straight (no excessive drag or pull to one side).
- _ Inspect seat and back upholstery for rips or sagging.
- _ Inspect back cane handgrips for wear, looseness, and/or deterioration.
- _ Inspect for any loose or broken hardware on the wheelchair.
- _ Inspect the seat-positioning strap for any signs of wear. Ensure the buckle latches. Verify that the hardware that attaches the strap to the frame is secure and undamaged. Replace if necessary.

_ Ensure that there is no excessive side movement or binding when the rear wheels are lifted and spun.

_ Inspect for cracked, broken or loose spokes.

_ Ensure the wheel/fork assembly has proper tension when the caster is spun. The caster should come to a gradual stop.

_ Loosen/tighten the locknut if the wheel wobbles noticeably or binds to a stop.

_ Ensure the wheel bearings are clean and free of moisture.

CAUTION

As with any vehicle, wheels and tires should be checked periodically for cracks and wear and should be replaced as necessary.

_ Inspect the tires for flat spots and wear.

_ Ensure the hand brakes do not interfere with the tires when rolling.

_ Ensure the hand brake pivot points are free of wear and looseness.

_ Ensure the hand brakes are easy to engage.

_ Clean upholstery and armrests.

Inspect/Adjust Weekly

_ Ensure the wheelchair rolls straight (no excessive drag or pull to one side).

_ Inspect for cracked, broken or loose spokes.

_ Ensure the wheel/fork assembly has proper tension when caster is spun. The caster should come to a gradual stop.

_ Ensure the hand brakes do not interfere with tires when rolling.

_ Ensure the hand brake pivot points are free of wear and looseness.

Inspect/Adjust Monthly

- _ Inspect for any loose or broken hardware on the wheelchair.
- _ Inspect back cane handgrips for wear, looseness, and/or deterioration.
- _ Loosen/tighten the locknut if the wheel wobbles noticeably or binds to a stop.
- _ Ensure the wheel bearings are clean and free of moisture.

CAUTION

As with any vehicle, the wheels and tires should be checked periodically for cracks and wear and should be replaced as necessary.

- _ Ensure the hand brakes do not interfere with the tires when rolling.

Inspect/Adjust Periodically

- _ Ensure the wheelchair rolls straight (no excessive drag or pull to one side).
- _ Inspect the seat and the back upholstery for rips or sagging.
- _ Inspect the seat-positioning strap for any signs of wear. Ensure the buckle latches. Verify that the hardware that attaches the strap to the frame is secure and undamaged. Replace if necessary.
- _ Ensure that there is no excessive side movement or binding when the rear wheels are lifted and spun.
- _ Ensure the wheel bearings are clean and free of moisture.

CAUTION

As with any vehicle, the wheels and tires should be checked periodically for cracks and wear and should be replaced as necessary.

- _ Inspect the tires for flat spots and wear.
- _ Ensure the hand brakes are easy to engage.
- _ Clean the upholstery and armrests.

Maintenance

Maintenance Safety Precautions

WARNING

After ANY adjustments, repair or service and BEFORE use, make sure all attaching hardware is tightened securely. Otherwise, injury or damage can result.

CAUTION

DO NOT over tighten the hardware attaching to the frame. This could cause damage to the frame tubing.

Suggested Maintenance Procedures

1. Before using your wheelchair make sure all the nuts and bolts are tight. Check all the parts for damage or wear and replace. Check all parts for proper adjustment.
2. The wheels and tires should be checked periodically for cracks and wear, and should be replaced by a qualified technician if damaged.
3. Periodically adjust the wheel locks in correlation to tire wear. Refer to **Adjusting**
4. Periodically check the front caster and the rear wheel hubs to make sure they are clean and free of cracks.

WARNING

When cleaning the rear cane or handgrip areas, use only a clean towel lightly dampened with cool water. Verify that grips are dry prior to use. The use of soap or ammonia based cleaning solutions will result in the handgrips sliding off the cane assembly. Failure to observe this warning could result in injury to the user or bystanders.

5. Hand grips should be checked monthly for wear/looseness. Clean if desired.
6. Check the upholstery for sagging, rips or tears.

FRONT RIGGINGS

WARNING

After ANY adjustments, repair or service and BEFORE use, make sure all attaching hardware is tightened securely. Otherwise, injury or damage may result.

Installing Swingaway Footrest Assembly

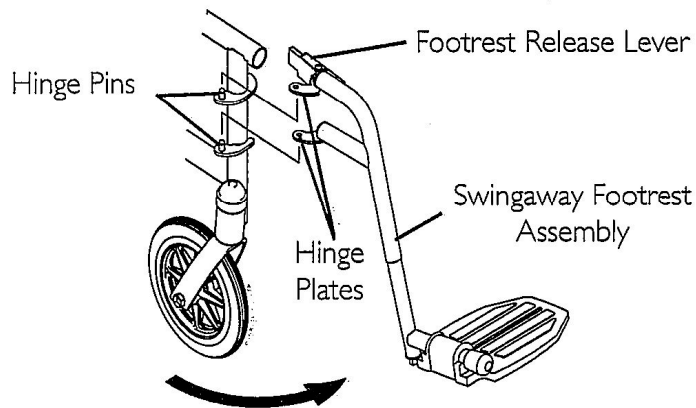

1. Turn the footrest to the side (open footplate is perpendicular to wheelchair).
2. Install the hinge plates on the footrest onto the hinge pins on the wheelchair frame.
3. Push the footrest towards the inside of the wheelchair until it locks into place.

NOTE: The footplate will be on the inside of the wheelchair when locked in place.

4. Repeat this procedure for the other footrest assembly.
5. To release the footrest, push the footrest release lever inward, rotate the footrest outward.

Adjusting Footplate Height

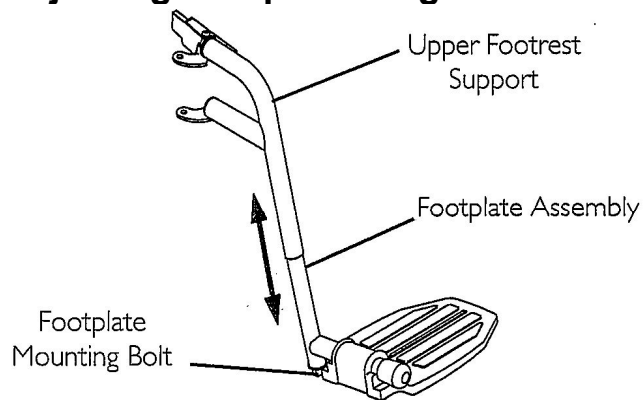

1. Remove the swingaway footrest assembly. Refer to **Installing Swingaway Footrest Assembly**.

NOTE: Lay the assembly on a flat surface to simplify this procedure.

2. Loosen, but do not remove, the footplate mounting bolt until the footplate assembly moves freely.

3. Reposition the footplate assembly to the desired height.

4. Securely tighten the footplate-mounting bolt.

5. Repeat this procedure for the other footrest, if necessary.

6. Reinstall the swingaway footrest assembly. Refer to **Installing Swingaway Footrest Assembly**.

BACK

WARNING

After **ANY** adjustments, repair or service and **BEFORE** use, make sure all attaching hardware is tightened securely. Otherwise, injury or damage could result.

Unfolding/Folding the Fold-Down Back

Folding

1. Disengage the release mechanism on the back canes.

2. Pull the handles down.

Unfolding

WARNING

When unfolding the back, ensure all occupant's and/or assistant's body parts are away from the folding mechanism. Otherwise, pinching and injury may occur. Make sure the release levers are securely locked in place **BEFORE** using the wheelchair.

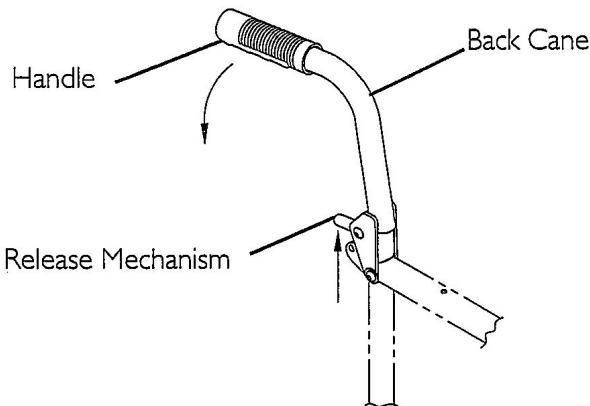

1. Pull up on the two (2) back canes until the release mechanisms lock in place.

NOTE: There will be an audible click.

2. Pull on the handles to make sure the back is locked in place.

Replacing Back Upholstery

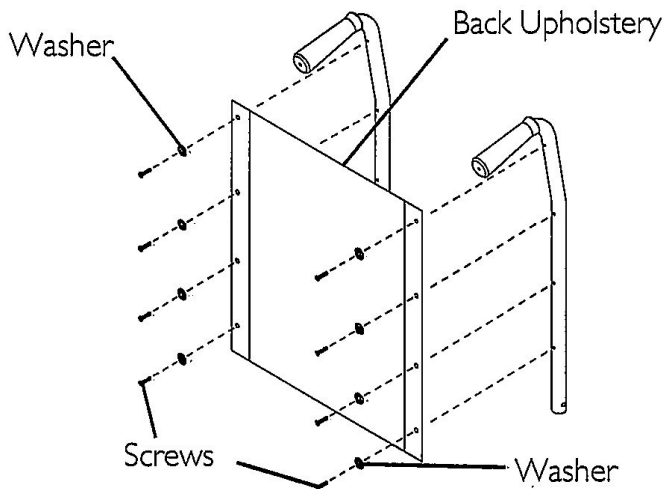

1. Remove the screws and washers that secure the existing back upholstery to the back canes.

2. Position new back upholstery on back canes.
3. Securely tighten the new back upholstery to the back canes with the screws and washers.

NOTE: The Lightweight Transport has ten (10) screws and washers. The Bariatric Transport has sixteen (16) screws and washers.

Replacing Seat Upholstery

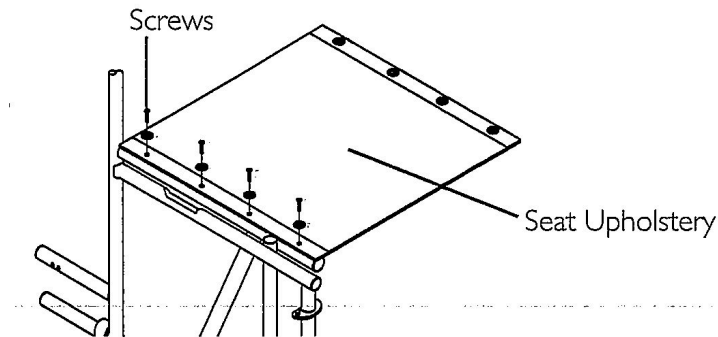

1. Remove the screws that secure the existing seat upholstery to the cross braces.
2. Remove the existing seat upholstery from the cross braces.
3. Install the new seat upholstery by reversing STEPS 1-2.

REAR WHEELS

WARNING

After ANY adjustments, repair or service and BEFORE use, make sure all attaching hardware is tightened securely. Otherwise, injury or damage could result.

CAUTION

As with any vehicle, the wheels and tires should be checked periodically for cracks and wear, and should be replaced.

Removing/Installing Rear Wheels

1. Remove the dust cap (if applicable), hex screw and locknut that secure the rear wheel

and axle spacer to the wheelchair.

2. Repeat STEP 1 for the opposite rear wheel.

3. To reinstall the rear wheels onto the wheelchair, reverse STEPS 1-2.

NOTE: Make sure the axle spacer is between the rear wheel and the wheelchair frame.

CASTERS

WARNING

After ANY adjustments, repair or service and BEFORE use, make sure all attaching hardware is tightened securely - otherwise injury or damage may result.

CAUTION

As with any vehicle, the wheels and tires should be checked periodically for cracks and wear, and should be replaced when necessary.

Replacing/Adjusting Front Forks

Replacing

1. Remove the caster from the fork. Refer to **Replacing Front Casters**.
2. Remove the dust cover.
3. Remove the locknut and nylon washer that secure the fork to the caster head tube.
4. Drop the fork out of the caster head tube.
5. Slide the new fork into the caster head tube and reassemble by reversing STEPS 1-4.
6. Adjust the forks.
7. Repeat STEPS 1-6 for the opposite fork, if necessary.

Adjusting

1. Remove the dust cover.
2. To properly tighten the caster journal system and guard against flutter, perform the following check:
 - A. Tip back the wheelchair to floor.
 - B. Simultaneously pivot both forks and casters to the top of their arc.
 - C. Let the casters drop to the bottom of the arc (wheels should swing once to one-side, then immediately rest in a straight downward position).
 - D. Adjust the locknuts according to freedom of the caster swing.
3. Test the wheelchair for maneuverability.
4. Readjust the locknuts if necessary, and repeat STEPS 2-3 until correct.
5. Snap the dust cover over the locknut and stem.

Replacing Front Casters

1. Remove the hex screw, washers and locknut that secure the front caster to the fork.
2. Install the new front caster onto the wheelchair by reversing STEP 1.
3. Repeat STEPS 1-2 for the opposite front caster if necessary.

HAND BRAKES/WHEEL LOCKS

WARNING

After ANY adjustments, repair or service and BEFORE use, make sure all attaching hardware is tightened securely. Otherwise, injury or damage may result.

DO NOT leave the Bariatric Transport on inclined surfaces. The wheel locks and hand brakes may not hold the Bariatric Transport on inclined surfaces due to the wheelchair's increased weight capacity.

Wheel locks are NOT brakes. DO NOT attempt to stop a moving wheelchair with the wheel locks.

Before attempting to transfer in or out of the wheelchair, every precaution should

be taken to reduce the gap distance. Turn both casters parallel to the object you are transferring onto. When transferring to and from the wheelchair, ALWAYS ENGAGE BOTH WHEEL LOCKS. If the wheelchair is equipped with hand brakes, ALWAYS LOCK BOTH HAND BRAKES before transferring to and from the wheelchair.

Locking/Unlocking/Using Hand Brakes

NOTE: These procedures are applicable only to the Bariatric Transport and the Lightweight Transport.

Locking Hand Brake

1. Push down on the bottom portion of the brake handle until an audible click is heard.
2. Refer to Unlocking Hand Brake.

Unlocking Hand Brake

1. Pull up on the top portion of the brake handle to release.
2. Release the brake handle.

Using Hand Brake

1. Pull UP on the top portion of the brake handles toward the push handles.
2. Do one (1) of the following:
 - Remain stationary - Hold the brake handle up.
 - Continue mobility - Release the brake handle.

Adjusting Hand Brakes

NOTE: This procedure is applicable only to the Bariatric Transport and the Lightweight Transport.

NOTE: Counterclockwise/clockwise directions are determined by standing behind the transport (user's position).

Test the brake handle. Observe how the brake lever engages the wheel. If the tension of the brake is too loose or too tight, adjust using the following steps:

1. Loosen the brake handle adjustment nut by turning clockwise.
2. Perform one (1) of the following:
 - Loosen brake handle tension - Turn the brake handle nut clockwise.**NOTE:** If the brake lever is scraping the rear wheel, the brake handle must be loosened.
 - Tighten brake handle tension - Turn the brake handle nut counterclockwise.**NOTE:** If the brake lever does not respond quickly, tighten brakes.
3. Turn the brake handle adjustment nut counterclockwise to secure in place.
4. Do one (1) of the following:
 - Acceptable tension - Repeat STEPS 1 - 3 for the opposite side, if necessary.
 - Unacceptable tension - Refer to **Adjusting Cable Adjuster**.

Adjusting Cable Adjuster Unit

Test the brake with the brake handle. Observe how the brake lever engages the wheel. If the tension of the brake handle is still too loose or too tight, adjust using the following steps:

1. Ensure brake handle is not locked.
2. To loosen: Brace the jam nut while turning the adjustment screw clockwise.
3. To tighten: Brace the jam nut while turning the adjustment screw counterclockwise.
4. Repeat with other brake.

Adjusting Wheel Lock

1. Loosen the bolt and locknut that secure the wheel lock assembly to the wheelchair frame.
2. Adjust the position of wheel lock until the measurement between the rear wheel and the wheel lock shoe is between 5/32 and 5/16-inches.
3. Securely tighten the bolt and locknut.
4. Engage the wheel lock, push against the wheelchair and determine if the wheel lock engages the wheel lock shoe enough to hold the wheelchair.
5. Repeat the above procedures until the wheel lock holds the wheelchair.
6. Repeat STEPS 1-5 for the opposite wheel lock.

LIMITED LIFETIME WARRANTY

PMI WARRANTS THIS PRODUCT TO BE FREE FROM DEFECTS IN MATERIALS AND WORKMANSHIP.

PLEASE NOTE: THE WARRANTY BELOW HAS BEEN DRAFTED TO COMPLY WITH FEDERAL LAW APPLICABLE TO PRODUCTS MANUFACTURED AFTER JULY 4, 1999.

THIS WARRANTY IS EXTENDED ONLY TO ORIGINAL PURCHASER/USER OF OUR PRODUCTS.

PMI WARRANTS ITS PRODUCTS TO BE FREE FROM DEFECTS IN MATERIAL AND WORKMANSHIP FOR THE LIFETIME OF USE BY ORIGINAL PURCHASER. IF WITHIN SUCH WARRANTY PERIOD ANY SUCH PRODUCT SHALL BE PROVEN TO BE DEFECTIVE, SUCH PRODUCT SHALL BE REPAIRED OR REPLACED, AT PMI'S OPTION. THIS WARRANTY DOES NOT INCLUDE ANY LABOR OR SHIPPING CHARGES INCURRED IN REPLACEMENT PART INSTALLATION OR REPAIR OF ANY SUCH PRODUCT. PMI'S SOLE OBLIGATION AND YOUR EXCLUSIVE REMEDY UNDER THIS WARRANTY SHALL BE LIMITED TO SUCH REPAIR AND/OR REPLACEMENT. FOR WARRANTY SERVICE, PLEASE CONTACT THE DEALER FROM WHOM YOU PURCHASED YOUR PMI PRODUCT. IN THE EVENT YOU DO NOT RECEIVE SATISFACTORY WARRANTY SERVICE, PLEASE WRITE DIRECTLY TO PMI AT THE ADDRESS ON THE BACK PAGE. PROVIDE DEALER'S NAME, ADDRESS, MODEL NUMBER, DATE OF PURCHASE, INDICATE NATURE OF THE DEFECT AND, IF THE PRODUCT IS SERIALIZED, INDICATE THE SERIAL NUMBER.

PMI WILL USE A RETURN AUTHORIZATION. THE DEFECTIVE UNIT OR PARTS MUST BE RETURNED FOR WARRANTY INSPECTION USING THE SERIAL NUMBER, WHEN APPLICABLE, AS IDENTIFICATION WITHIN 30 DAYS OF RETURN AUTHORIZATION DATE. DO NOT RETURN PRODUCTS TO US WITHOUT

PRIOR CONSENT. C.O.D. SHIPMENTS WILL BE REFUSED: PLEASE REPAY SHIPPING CHARGES.

LIMITATIONS AND EXCLUSIONS: THE WARRANTY SHALL NOT APPLY TO PROBLEMS ARISING FROM NORMAL WEAR OR FAIL TO ADHERE TO THE ENCLOSED INSTRUCTIONS. IN ADDITION, THE FOREGOING WARRANTY SHALL NOT APPLY TO SERIAL NUMBERED PRODUCTS IF THE SERIAL NUMBER HAS BEEN REMOVED OR DEFACED; PRODUCTS SUBJECTED TO NEGLIGENCE, ACCIDENT, IMPROPER OPERATION, MAINTANENCE OR STORAGE; OR PRODUCTS MODIFIED WITHOUT PMI'S EXPRESS WRITTEN CONSENT (INCLUDING, BUT NOT LIMITED TO MODIFICATION THROUGH THE USE OF UNAUTHORIZED PARTS OR ATTACHMENTS, PRODUCTS DAMAGED BY REASON OF REPAIRS MADE TO ANY COMPONENT WITHOUT SPECIFIC CONSENT OF PMI; PRODUCTS DAMAGED BY CIRCUMSTANCES BEYOND PMI'S CONTROL; PRODUCTS REPAIRED BY ANYONE OTHER THAN AN AUTHORIZED PMI DEALERS). SUCH EVALUATION SHALL BE SOLELY DETERMINED BY PMI.

THE FOREGOING WARRANTY IS EXCLUSIVE AND IN LIEU OF ALL OTHER EXPRESS WARRANTIES, IF ANY, INCLUDING THE IMPLIED WARRANTIES OF MERCHANTABILITY AND FITNESS FOR A PARTICULAR PURPOSE, AND SHALL NOT EXTEND BEYOND THE DURATION OF THE EXPRESS WARRANTY PROVIDED HEREIN AND THE REMEDY FOR VIOLATIONS OF ANY IMPLIED WARRANTY SHALL BE LIMITED TO REPAIR OR REPLACEMENT OF THE DEFECTIVE PRODUCT PURSUANT TO THE TERMS CONTAINED HEREIN. PMI SHALL NOT BE LIABLE FOR ANY CONSEQUENTIAL OR INCIDENTAL DAMAGES WHATSOEVER.

THIS WARRANTY SHALL BE EXTENDED TO COMPLY WITH STATE/PROVINCIAL LAWS AND REQUIREMENTS.

ALL PRODUCTS LEAVE OUR WAREHOUSE IN BRAND NEW CONDITION. IT IS THE CUSTOMER'S RESPONSIBILITY TO EXAMINE ALL SHIPMENTS FOR DAMAGE IMMEDIATELY UPON ARRIVAL. COUNT THE PACKAGES AND SIGN FOR SAFE DELIVERY. SIGN ONLY FOR WHAT YOU RECEIVE. IF MERCHANDISE IS DAMAGED CALL CARRIER AND SECURE DAMAGE INSPECTION REPORT YOU HAVE 15 DAYS TO SECURE DAMAGE REPORTS OTHERWISE YOU MAY LOSE YOUR PRIVILEGE OF FILING A CLAIM FOR LOSS OR DAMAGE.

FREIGHT POLICY: PLEASE CONTACT YOUR SALES REPRESENTATIVE FOR DETAILS.

For Service Call Your Authorized [PROBASICS](#) Medical Dealer:



15 South Main Street
2nd Floor
Marlboro, New Jersey 07746
www.pmiusa.biz