



COMMODOES

OPERATORS MANUAL

MODEL NO.	413	Drop Arm Commode
MODEL NO.	413BAR	Bariatric Drop Arm Commode
MODEL NO.	411	Bariatric Commode
MODEL NO.	410	Bariatric Commode

Drop Arm Commode



Bariatric Commode



Bariatric Drop Arm Commode



NOTE: Check ALL parts for shipping damage before use.
In case of shipping damage, DO NOT use. Contact Carrier/Dealer for further instruction.

Index

1.	Warnings	2
2.	Installations Warnings	2
3.	Leg Height Adjustment	2
4.	Installing/Removing the Commode Seat and Lid	3
5.	Operating Drop Arm	3
5.	Care and Lubrication	4
6.	Limited Lifetime Warranty	5

SAFETY INFORMATION

The following recommendations are made for the safe operation and adjustment of the Commode:

WARNINGS

Users with limited physical capabilities should be supervised or assisted when using the commode

Leg extensions with rubber tips **MUST** be in contact with the floor at all times.

The Bariatric Commode #410 has a weight capacity of 650 lbs.

The Bariatric Commode #411 has a weight capacity of 400 lbs.

The Bariatric Drop Arm Commode #413BAR has a weight capacity of 650 lbs.

The Drop Arm Commode #413 has a weight capacity of 300 lbs.

INSTALLATION WARNINGS

Ensure that the snap buttons fully protrude through the same respective adjustment hole of each leg extension. This ensures that the leg extensions are securely locked into position and an even height adjustment is achieved.

Make certain ALL screws, nut and /or bolts are tight at all times.

Inspect rubber tips on the leg extensions for rips, tears, cracks or wear or if they are missing. Replace them immediately if any of these conditions exist.

Back tube wing nuts **MUST** be inspected regularly for proper tightness- otherwise injury or damage may occur

LEG HEIGHT ADJUSTMENT

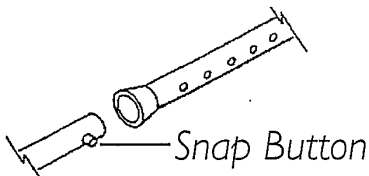

1. Select desired height for commode by aligning snap button of each leg extension with appropriate adjustment hole in leg frame.
2. Ensure snap buttons are fully engaged into adjustment hole of each leg frame and are at the same height before using.

CAUTION

Before removing/installing seat and lid, allow seat/lid to reach room temperature if exposed to cold. This will help prevent the seat clamps from breaking when being removed/installed onto commode back frame rail.

INSTALLING/REMOVING THE COMMODE SEAT AND LID

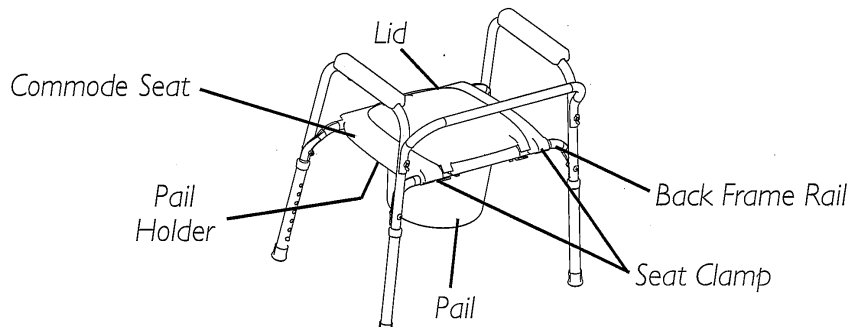

1. Align the seat clamps of the commode seat onto the back frame rail. **(Each clamp should sit outside the pail holders).** Push down on seat until it clamps firmly into place.
2. Repeat the same process for the lid. **(Not applicable for the Bariatric Drop Arm Commode 413BAR)**
3. When removing the seat or lid, remove the lid first and then the seat. To remove, grasp the back corner of the lid and/or seat and lift up firmly. **(Not applicable for the Bariatric Drop Arm Commode 413BAR)**

WARNING

Commode seat **MUST** be **DOWN** before sitting on the commode. Pail holders are **NOT** constructed to support the weight of an individual, **ONLY** the pail and its contents.

OPERATING DROP ARM

Bariatric Drop Arm Commode #413BAR

1. To drop arm on commode press in the easy release lever located at the end of the drop arm.
2. To engage drop arm just pull the arm up until it clicks into position.

Drop Arm Commode #413

1.

CARE AND LUBRICATION

CARE

Use a damp cloth and soap to clean.

LUBRICATION

To make raising or lowering the seat/lid easier, you may lubricate the commode back frame rail with a very small amount of petroleum jelly.

LIMITED WARRANTY

PMI WARRANTS THIS PRODUCT TO BE FREE FROM DEFECTS IN MATERIALS AND WORKMANSHIP.

THIS WARRANTY IS EXTENDED ONLY TO ORIGINAL PURCHASER/USER OF OUR PRODUCTS.

PMI WARRANTS ITS PRODUCTS TO BE FREE FROM DEFECTS IN MATERIAL AND WORKMANSHIP FOR A PERIOD OF 2 YEARS OF USE BY ORIGINAL PURCHASER. IF WITHIN SUCH WARRANTY PERIOD ANY SUCH PRODUCT SHALL BE PROVEN TO BE DEFECTIVE, SUCH PRODUCT SHALL BE REPAIRED OR REPLACED, AT PMI'S OPTION. THIS WARRANTY DOES NOT INCLUDE ANY LABOR OR SHIPPING CHARGES INCURRED IN REPLACEMENT PART INSTALLATION OR REPAIR OF ANY SUCH PRODUCT. PMI'S SOLE OBLIGATION AND YOUR EXCLUSIVE REMEDY UNDER THIS WARRANTY SHALL BE LIMITED TO SUCH REPAIR AND/OR REPLACEMENT. FOR WARRANTY SERVICE, PLEASE CONTACT THE DEALER FROM WHOM YOU PURCHASED YOUR PMI PRODUCT. IN THE EVENT YOU DO NOT RECEIVE SATISFACTORY WARRANTY SERVICE, PLEASE WRITE DIRECTLY TO PMI AT THE ADDRESS ON THE BACK PAGE. PROVIDE DEALER'S NAME, ADDRESS, MODEL NUMBER, DATE OF PURCHASE, INDICATE NATURE OF THE DEFECT AND, IF THE PRODUCT IS SERIALIZED, INDICATE THE SERIAL NUMBER.

PMI WILL USE A RETURN AUTHORIZATION. THE DEFECTIVE UNIT OR PARTS MUST BE RETURNED FOR WARRANTY INSPECTION USING THE SERIAL NUMBER, WHEN APPLICABLE, AS IDENTIFICATION WITHIN 30 DAYS OF RETURN AUTHORIZATION DATE. DO NOT RETURN PRODUCTS TO US WITHOUT PRIOR CONSENT. C.O.D. SHIPMENTS WILL BE REFUSED: PLEASE REPAY SHIPPING CHARGES.

LIMITATIONS AND EXCLUSIONS: THE WARRANTY SHALL NOT APPLY TO PROBLEMS ARISING FROM NORMAL WEAR OR FAIL TO ADHERE TO THE ENCLOSED INSTRUCTIONS. IN ADDITION, THE FOREGOING WARRANTY SHALL NOT APPLY TO SERIAL NUMBERED PRODUCTS IF THE SERIAL NUMBER HAS BEEN REMOVED OR DEFACED; PRODUCTS SUBJECTED TO NEGLIGENCE, ACCIDENT, IMPROPER OPERATION, MAINTENANCE OR STORAGE; OR PRODUCTS MODIFIED WITHOUT PMI'S EXPRESS WRITTEN CONSENT (INCLUDING, BUT NOT LIMITED TO MODIFICATION THROUGH THE USE OF UNAUTHORIZED PARTS OR ATTACHMENTS, PRODUCTS DAMAGED BY REASON OF REPAIRS MADE TO ANY COMPONENT WITHOUT SPECIFIC CONSENT OF PMI; PRODUCTS DAMAGED BY CIRCUMSTANCES BEYOND PMI'S CONTROL; PRODUCTS REPAIRED BY ANYONE OTHER THAN AN AUTHORIZED PMI DEALERS). SUCH EVALUATION SHALL BE SOLELY DETERMINED BY PMI.

THE FOREGOING WARRANTY IS EXCLUSIVE AND IN LIEU OF ALL OTHER EXPRESS WARRANTIES, IF ANY, INCLUDING THE IMPLIED WARRANTIES OF MERCHANTABILITY AND FITNESS FOR A PARTICULAR PURPOSE, AND SHALL NOT

EXTEND BEYOND THE DURATION OF THE EXPRESS WARRANTY PROVIDED HEREIN AND THE REMEDY FOR VIOLATIONS OF ANY IMPLIED WARRANTY SHALL BE LIMITED TO REPAIR OR REPLACEMENT OF THE DEFECTIVE PRODUCT PURSUANT TO THE TERMS CONTAINED HEREIN. PMI SHALL NOT BE LIABLE FOR ANY CONSEQUENTIAL OR INCIDENTAL DAMAGES WHATSOEVER.

THIS WARRANTY SHALL BE EXTENDED TO COMPLY WITH STATE/PROVINCIAL LAWS AND REQUIREMENTS.

ALL PRODUCTS LEAVE OUR WAREHOUSE IN BRAND NEW CONDITION. IT IS THE CUSTOMER'S RESPONSIBILITY TO EXAMINE ALL SHIPMENTS FOR DAMAGE IMMEDIATELY UPON ARRIVAL. COUNT THE PACKAGES AND SIGN FOR SAFE DELIVERY. SIGN ONLY FOR WHAT YOU RECEIVE. IF MERCHANDISE IS DAMAGED CALL CARRIER AND SECURE DAMAGE INSPECTION REPORT YOU HAVE 15 DAYS TO SECURE DAMAGE REPORTS OTHERWISE YOU MAY LOSE YOUR PRIVILEGE OF FILING A CLAIM FOR LOSS OR DAMAGE.

FREIGHT POLICY: PLEASE CONTACT YOUR SALES REPRESENTATIVE FOR DETAILS.

For Service Call Your Authorized **PROBASICS** Medical Dealer:



15 South Main Street
2nd Floor
Marlboro, New Jersey 07746
www.pmiusa.biz