

TKO[®]

Sit-up Bench

Model 864SB



TKO SPORTS GROUP USA LIMITED

7354 Denny Road #100 Houston, TX 77040

IMPORTANT SAFETY INSTRUCTIONS

TKO Fitness products are designed and manufactured to the highest standards in order to provide you with years of great workouts. We proudly stand behind all our products with the best customer service in the fitness industry. If you have any question or need assistance please contact us at:

**Customer Service: customerservice@tko.com
Toll free: 866-856-3488 or 713-895-9270
Monday-Friday 8:30am to 4:30pm CT**

- Inspect your machine prior to exercise to ensure that all nuts and bolts are fully tightened.
- Replace the worn parts immediately.
- Most exercise equipment is not recommended for small children. Children should not use the machine unless they are under adult supervision.
- Exercise equipment has moving parts. In the interest of safety, keep others, especially children, at a safe distance while exercising.
- Warm up 5 to 10 minutes before each workout and cool down 5 to 10 minutes afterward. Never hold your breath while exercising.
- Rest adequately between workouts. Muscles tone and develop during these rest periods. Beginners should work out twice a week and increase gradually to 4 to 5 times per week.
- Remove all jewelry, including rings, chains and pins before commencing exercise.
- Always wear suitable clothing and footwear during exercise. Do NOT wear loose fitting clothing that could become entangled with the moving parts of your exercise machine.

MEDICAL WARNING

- Before beginning any exercise program, consult your personal physician. Evaluate your present fitness level and determine the exercise program that is most appropriate for your particular age and condition.
- If you experience any pain or tightness in your chest, irregular heartbeats, shortness of breath, faintness or other unusual discomfort while exercising, stop and consult your physician before continuing.

Maximum recommended exercise weights not to exceed 280lbs

EXPLODED DRAWING & PARTS LIST

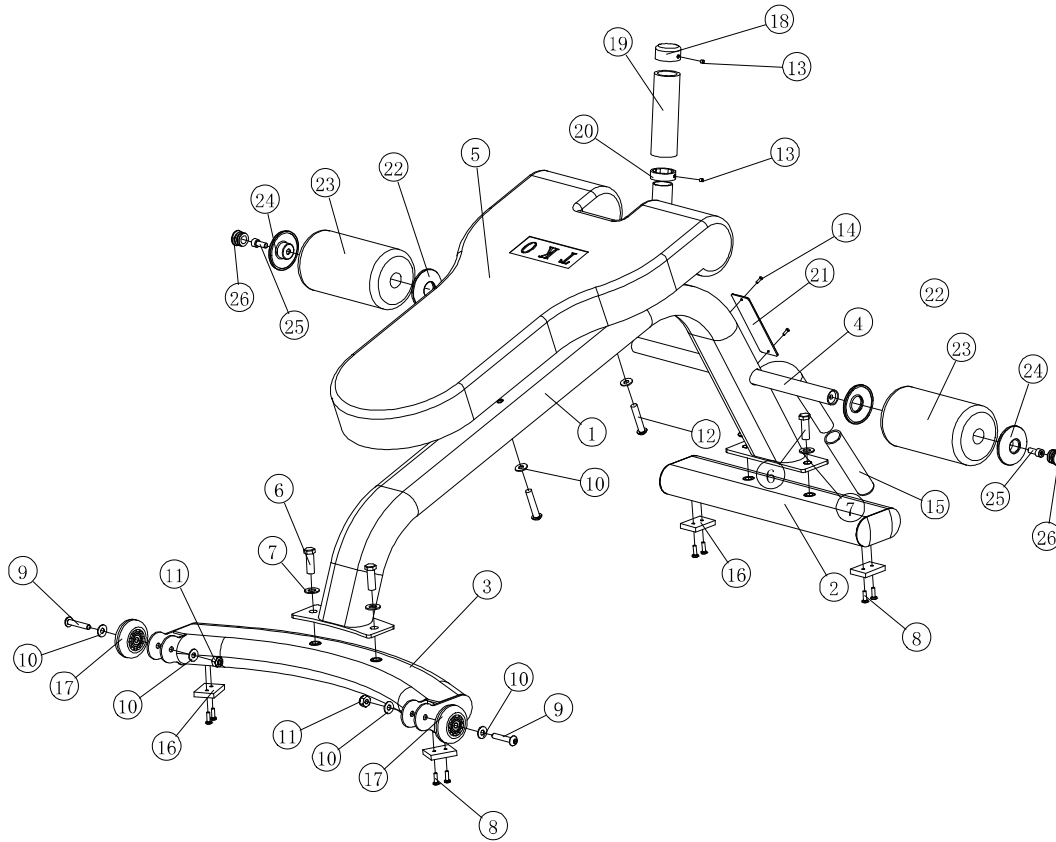

No.	Description	Q'ty	No.	Description	Q'ty
1	Main Frame	1	14	Rivet Φ 3.2x10mm	2
2	Base Frame	1	15	Hand Grip	1
3	Base Stabilizer	1	16	Rubber Floor Pad	4
4	Foam Roller Tube	1	17	Transport Wheel	2
5	Back Pad	1	18	Plastic Cap	1
6	Hex Bolt M12x20mm	4	19	Foam grip	1
7	Washer for M12 Bolt	4	20	Hand Grip Metal Ring	1
8	Phillips Head Bolt M5x15mm	8	21	Name Plate	1
9	Allen Bolt M8x45mm	2	22	Foam Roller Inner Cap	2
10	Washer for M8 Bolt	6	23	Foam Roller	2
11	Lock Nut for M8 Bolt	2	24	Foam Roller Outer Cap	2
12	Allen Bolt M8x70mm	2	25	Allen Bolt M8x20mm	2
13	Screw M6x4	2	26	PVC Plug	2

ASSEMBLY INSTRUCTIONS

Note: Before starting assembly remove all parts and hardware from the carton, ensure you have everything according to the list.

Step 1

Attach the Front Frame (2) and the Rear Frame (3) to the Main Frame (1), using 4 Washers (7) and 4 Hex Bolts (6).

Step 2

Insert the Foam Tube (4) into the hole of the Main Frame (1), insert the Inner Foam Cap (22) and the Foam (23) to the Foam Tube (4), attach the outer Foam Cap to the Foam Tube (4), using the Allen Bolt (25) to tighten it, put the Plug (26) into the Outer Foam Cap (24).

Step 3

Attach the Seat Pad (5) to the Main Frame (1), using 2 Washers (10) and 2 Allen Bolts (12).

Tighten all the bolts with wrenches.

