

RM-KB-LCD

KEYBOARD WITH LCD DISPLAY

ASSEMBLY INSTRUCTIONS



- NOTE:** 1) This product requires front and rear mounting using an 18.75" to 20.25" and 23.50" to 26.25" range. Pre-configure rackrail within this range prior to installation of unit
- 2) Before installation, make sure all peripherals and computers have been turned off. RM-KB-LCD must be locked in the closed position during installation

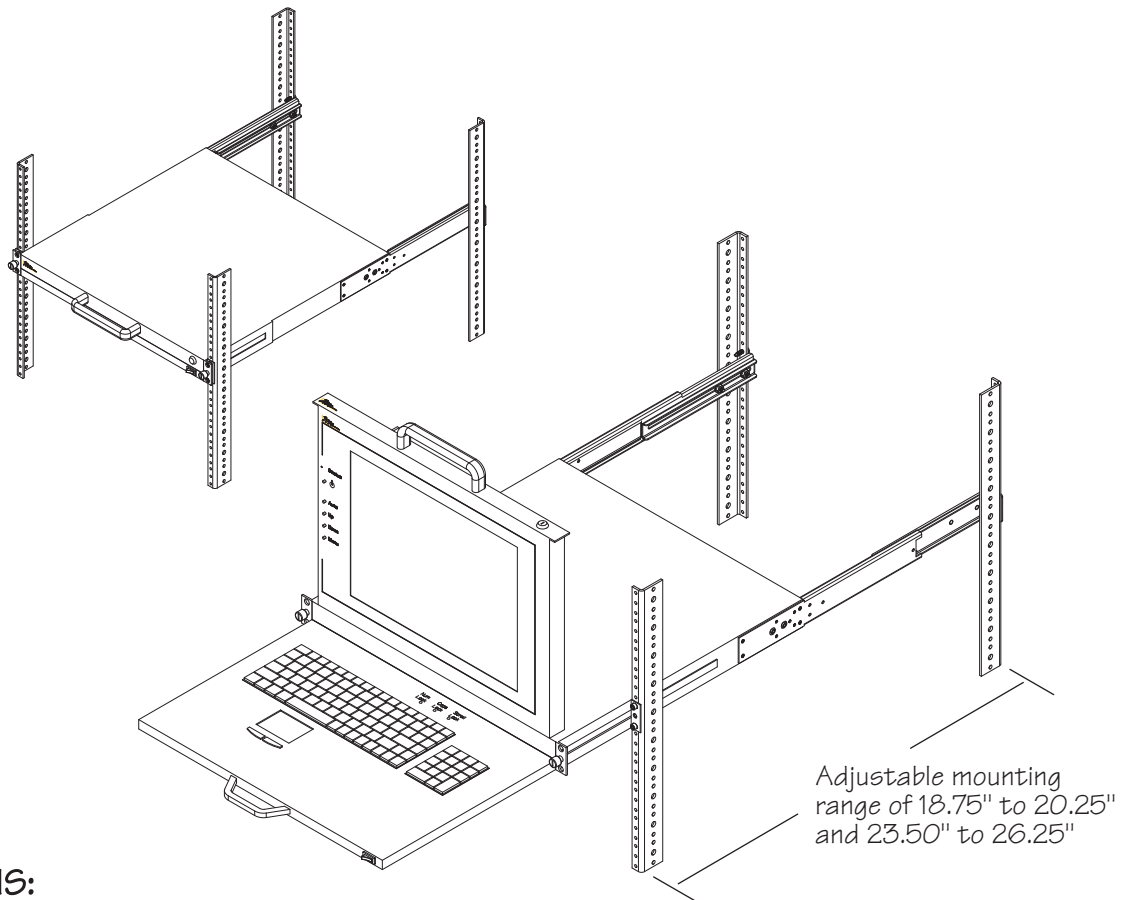

SPECIFICATIONS:

Bright active matrix TFT LCD Display
 screen resolution: 1024 X 768 (15" screen)
 1280 X 1024 (17" screen)

Rear articulating cable carriers provide cable strain relief
 Dual slide system allows for system monitoring while keyboard is in the closed position
 105 key PS/2 keyboard with touch pad pointing device
 Compact 1 space size

CAUTION: There may be systems, or external USB ports, with which this product will not be compatible

TOOLS NEEDED:

- No. 2 Phillips Screwdriver
- 3/8" Nut Driver

HARDWARE KIT CONTENTS:

Rack screws (4)

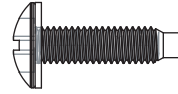

Hex key (1)



Cap screw (4)

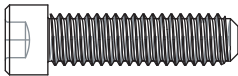

Adjustable rear support ear (2)
for 18.75" to 20.25"
mounting range

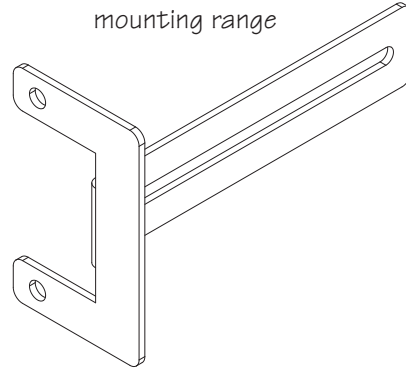

Adjustable rear support ear (2)
for 23.50" to 26.25"
mounting range

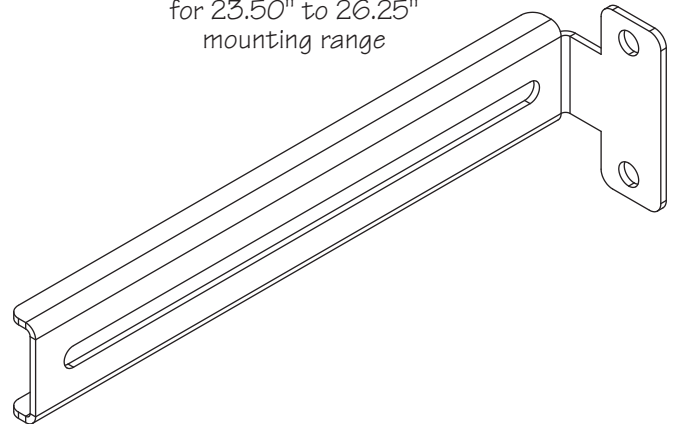

Flat head screw (8)

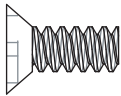

Rear support extension
(1 left and 1 right)

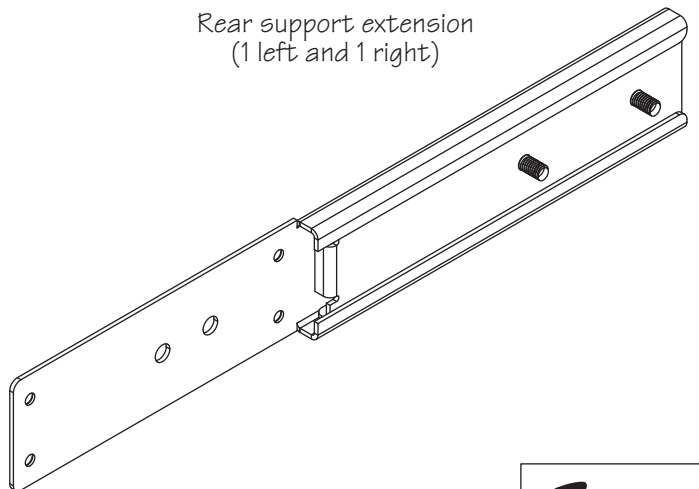

Lock nut (4)

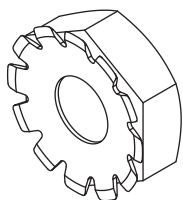

1) Remove 4 flat head screws from each side and discard (See **FIGURE A**)

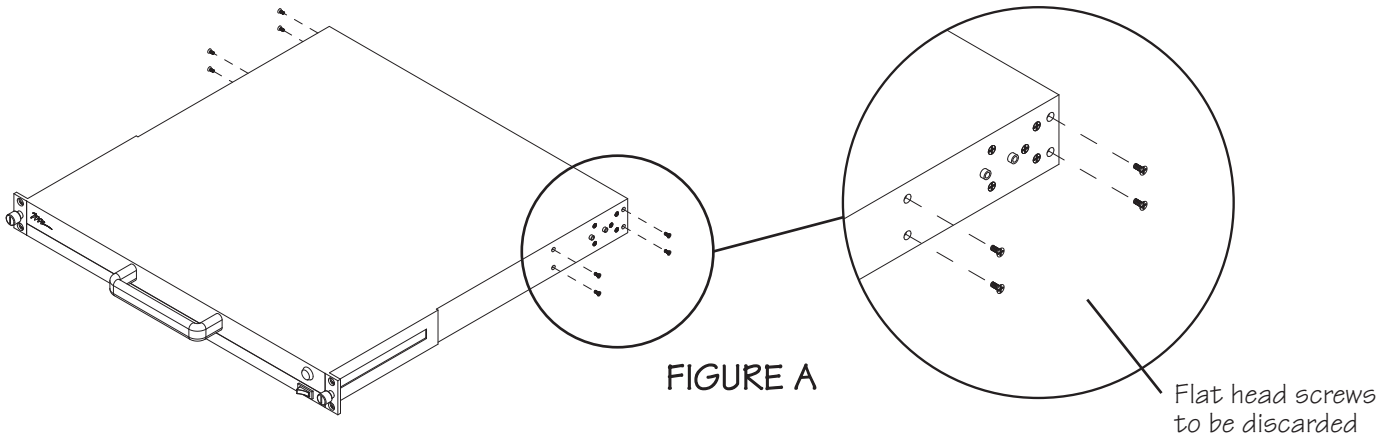

2) Install rear left and right support extensions using supplied flat head screws (4 per extension) (See **FIGURE B**)

TIP: Install all screws before final tightening

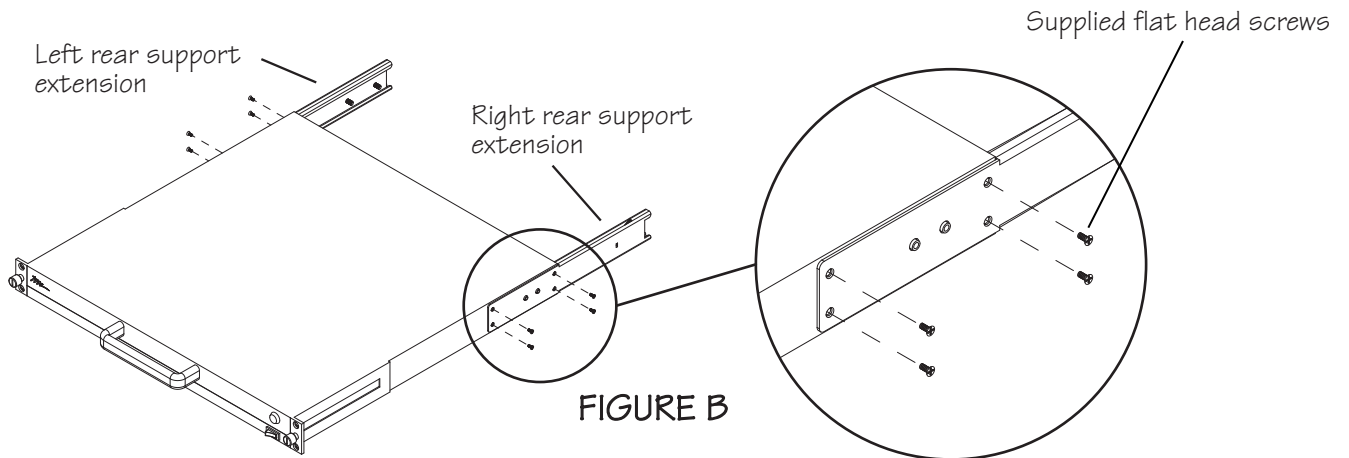

3) Using hex key and cap screws (one per side) mount unit to the front rackrail, using upper mounting point. Do not tighten (See **FIGURE C**)

NOTE: 1) 2nd person required for rear support during installation

2) Unit shown partially extended for clarity. Not required for installation

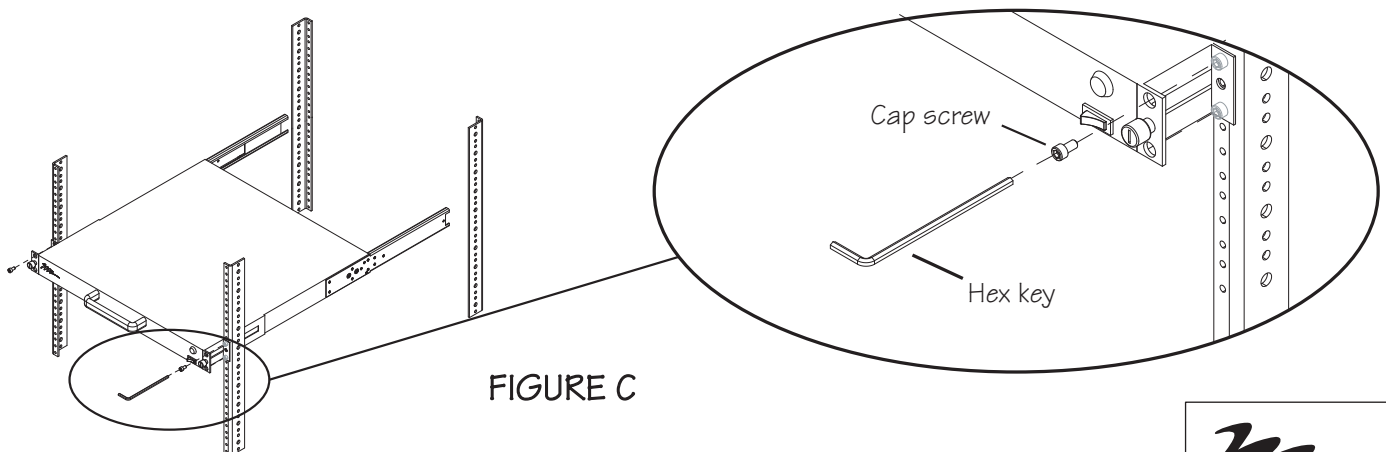

When installing rackmount keyboard using the 23.50" to 26.25" mounting range, (see **FIGURE D**)
When installing rackmount keyboard using the 18.75" to 20.25" mounting range, (see **FIGURE E**)

- 4) With unit in closed position, install rear support ears onto slider. Loosely install nuts
- 5) Attach rear support ears to rackrails using provided rack screws (2 per side). Adjust slides forward so they can not extend any further. Tighten nuts

NOTE: 1) Rear support ears attach to face (outside) of rear rackrail

- 2) When installing rackmount keyboard in rack with front door make sure unit is set back enough so the door clears the handle

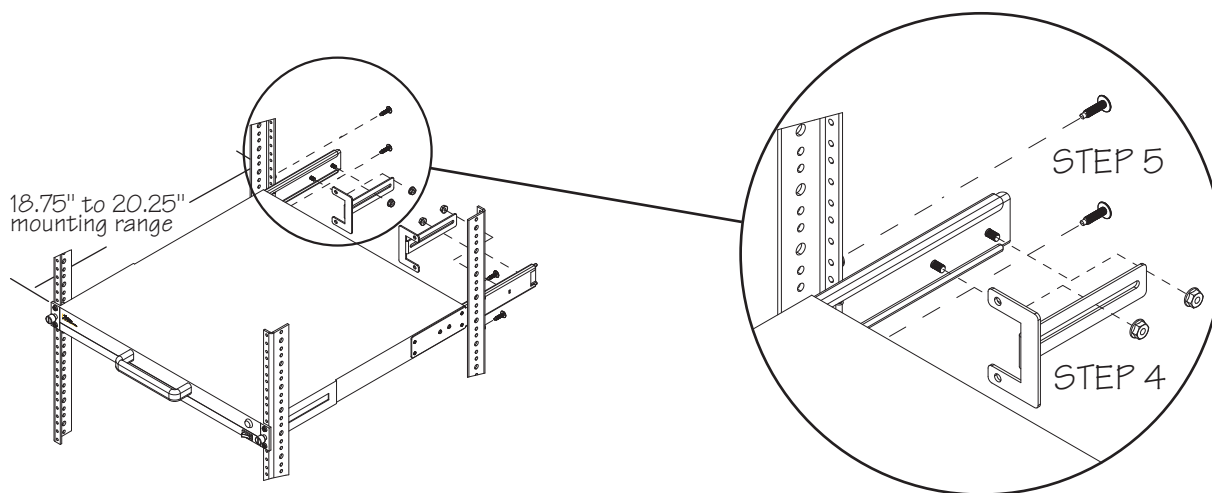
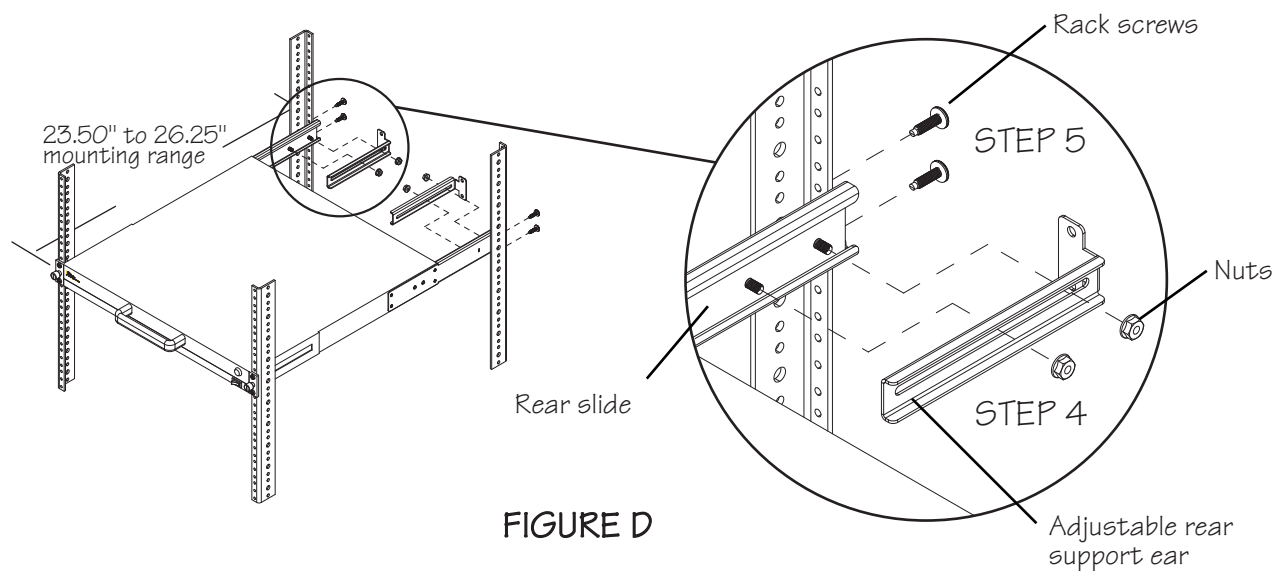

- 6) Install bottom 2 cap screws into front ears and tighten all 4 cap screws on front (See **FIGURE F**)

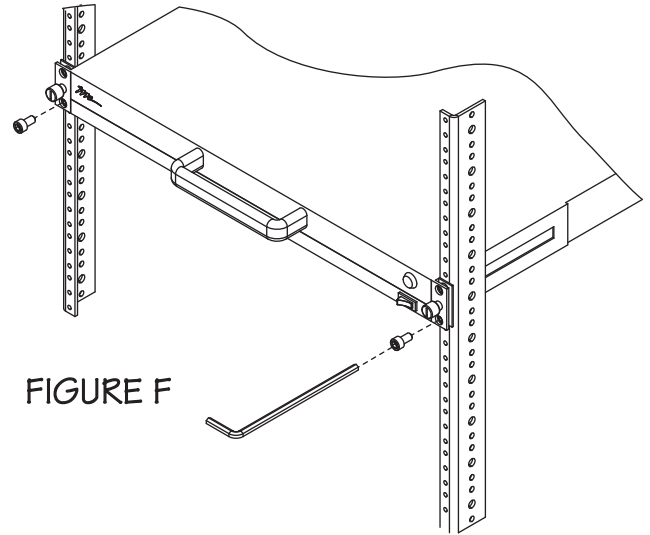

FIGURE F

- 7) Attach provided connectors and power supply (See **FIGURE G**). Refer to "Connection Recommendations" on page 6

FIGURE G
(Rear view)



Connectors

Power supply inlet

CONTROL PANEL:

- 1) Power Indicator Light:
The LED light will be turned on and off with the power

- 2) Power: Turns the power on/off

NOTE: Master power switch must be in 'ON' position

- 3) AUTO TUNE:
Press to auto adjust the monitor image

- 4) To move Up

- 5) To move Down

- 6) MENU / ENTER:
Pressing MENU / ENTER button will display the Onscreen Display menu.
This button also allows you to select items on the menu

Control Panel

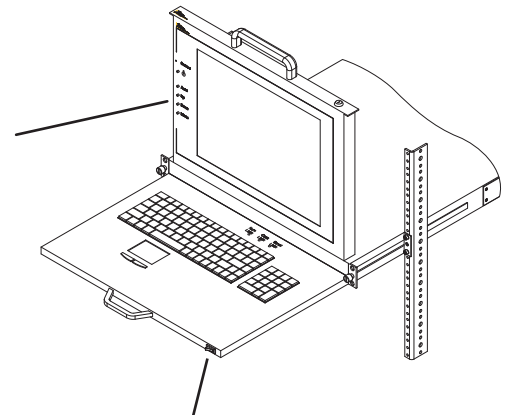
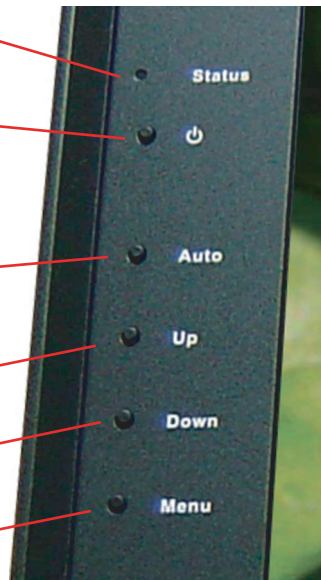

Master power switch

ONSCREEN DISPLAY MENU:

How to use Onscreen Display Menu:

- 1) Press MENU / ENTER button to display the main menu
- 2) Press the UP / DOWN buttons to select the item you wish
- 3) Press MENU / ENTER key to enter sub menu
- 4) Select EXIT and press MENU / ENTER to close MENU

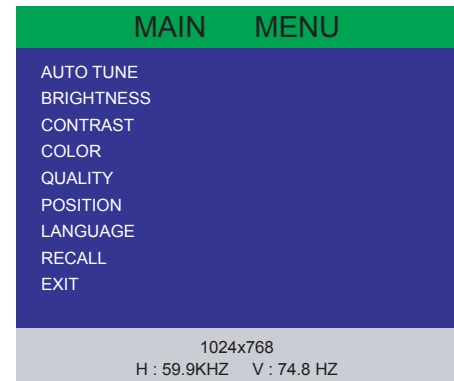

CONNECTION RECOMMENDATIONS:

- 1) Fully extend keyboard and secure cables with service loop. Verify that cables are free of pinch points in the retracted position. Do not use rear extensions for cable tie points
- 2) The recommended VGA cable distance is 16 feet (5 meters) maximum to avoid ghosting and degradation
- 3) The recommended PS/2 cable distance is 16 feet (5 meters) maximum. Normally, the cable length is based on driver capacity of your motherboard PS/2 port. If you need a longer PS/2 cable, use a PS/2 extender
- 4) Ensure that all cables are properly seated

CERTIFICATIONS:



This equipment has been tested and found to comply with Part 15 of the FCC Rules.

Operation is subject to the following two conditions:

- (1) This device may not cause harmful interference
- (2) This device must accept any interference relieved. Including interference that may cause undesired operation



This equipment is in compliance with the requirements of the following regulations:
EN 55 022: CLASS B

NO HASSLE 1 YEAR LIMITED WARRANTY

Middle Atlantic Products, Inc. (the "Company") warrants the products manufactured by it to be free from defects in material or workmanship under normal use and conditions for a period of one (1) year from date of shipment by the Company. The Company's entire liability to the purchaser, and the purchaser's (or any other party's) sole and exclusive remedy, under this warranty shall be limited, at the Company's option, to either (a) return of and refund of the price paid for, or (b) repair or replacement at the Company's factory of the products purchased, or any part or parts thereof, which the Company has determined to be defective after inspection thereof at the Company's factory. This warranty does not cover damage due to acts of God, accident, misuse, abuse or negligence by parties other than the Company, or any modification or alteration of the products. In addition, this warranty does not cover damage due to improper handling, assembly, installation or maintenance.

THIS WARRANTY IS IN LIEU OF ALL OTHER WARRANTIES OF ANY KIND, EITHER EXPRESS OR IMPLIED, INCLUDING, BUT NOT LIMITED TO, IMPLIED WARRANTIES OF MERCHANTABILITY AND FITNESS FOR A PARTICULAR PURPOSE. TO THE MAXIMUM EXTENT PERMITTED BY APPLICABLE LAW, IN NO EVENT SHALL THE COMPANY BE LIABLE FOR ANY SPECIAL, INCIDENTAL, INDIRECT, OR CONSEQUENTIAL DAMAGES WHATSOEVER (INCLUDING, WITHOUT LIMITATION, DAMAGES FOR LOSS OF BUSINESS PROFITS, BUSINESS INTERRUPTION OR ANY OTHER PECUNIARY LOSS) ARISING OUT OF THE USE OF THE PRODUCTS PURCHASED, EVEN IF THE COMPANY HAS BEEN ADVISED OF THE POSSIBILITY OF SUCH DAMAGES. THE COMPANY'S LIABILITY TO THE PURCHASER (OR ANY OTHER PARTY) HEREUNDER, IF ANY, SHALL IN NO EVENT EXCEED THE PURCHASE PRICE OF THE PRODUCTS PAID TO THE COMPANY.

