

Installation

Lenox Lockers™

(includes Cubby & “Z” Lockers)

(U.S. Patent No. 6,685,285)

⚠ WARNING ⚠

Read this installation manual completely to ensure proper installation, then file it with the owner or maintenance department.

Separate parts from packaging and make sure all parts are accounted for before discarding any packaging material. If any parts are missing, do not begin installation until you obtain the missing parts.

Lockers should be installed in a climate-controlled environment and shielded from direct sunlight. All lockers must be either secured against a wall or installed back-to-back (for island configuration).

Make sure all floors and walls are clean and smooth. Remove loose impediments, such as protruding nails, and other debris which could affect installation. The lockers must be square AND level AND floor-supported or they will not operate properly (a locker that is square may not be level so be sure to check both).

Review your locker layout drawings and verify the number of lockers and components before beginning installation.

Carefully lift lockers at the base when moving and positioning. Do not drag the lockers!

Lockers and slope top components are extremely heavy and may require more than one person to position and install.

Standard lockers are shown in most illustrations. Cubby lockers and “Z” lockers are similar and are installed in the same manner.

OPTIONAL LOCKER BASE MUST BE SQUARE AND LEVEL, AND ANCHORED TO THE FLOOR BEFORE LOCKERS ARE INSTALLED. THE LOCKERS WILL NOT OPERATE PROPERLY IF THE BASE IS NOT SQUARE AND LEVEL AND NOT FLOOR-SUPPORTED. A LOCKER THAT IS SQUARE MAY NOT BE LEVEL SO BE SURE TO CHECK BOTH!

FAILURE TO COMPLY WITH THESE INSTRUCTIONS MAY RESULT IN PERSONAL INJURY AND/OR PROPERTY DAMAGE AND WILL VOID THE LOCKER WARRANTY.

Product warranties may be found under “Product Information” on our web site at www.bradleycorp.com.

Table of Contents

Pre-Installation Information	2
Hardware List	3
Locker Base Installation	4
Corner Filler Installation	5
Locker Installation	6–8
Slope Top Installation	9–10
Flat Top Installation	11–12
End Panel Installation	12
Back-to-back Locker Installation	13
Back-to-back Slope Top Installation	14–15
Island End Panel Installation	15

Pre-Installation Information

Check Contents

Separate all parts from packaging materials and ensure you have all parts required for installation. If any parts are missing, do not attempt to install your Lenox Lockers until you obtain all parts.

Supplies required

For lockers with no base, you will need floor anchors and appropriate hardware suitable for your application. For optional fillers, you will need blocking (for support) and suitable fasteners.

Tools required

- Tape measure
- 9/32" drill bit
- Hammer drill (for drilling into concrete)
- 6' level and shims (for standard lockers)
- Pop rivet gun (for number plates on standard lockers)
- Right-Angle Power Drill (for 12" wide and 12" deep lockers)
- Power drill
- Phillips driver bit
- Clamps
- 3/16" masonry drill bit (minimum 6" long)
- OPTIONAL: chalk and/or string

Troubleshooting Tips

Properly installed lockers will need little adjustment. However, the following tips may be helpful:

- A chalk line drawn across the locker banks over the doors will help provide a visual inspection. This is only an aid and does not replace squaring and leveling the lockers.
- A string line along the top and bottom of the lockers may also be used to help in alignment.
- If shims are required after locker installation is complete, remove obstructive screws, apply the shims then replace the screws.
- Avoid twisting the locker frames when applying shims.

Hardware List (hardware provided by Bradley)

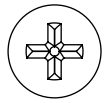

FAST-LF015

1/4" x 1-3/4" Lg. Tapcon screw for base and locker mounting

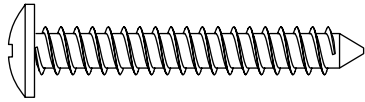

FAST-S357

#14 x 1-3/4" Lg. screw for locker mounting



FAST-T349

#10 x 1/2" Lg. screw for base



FAST-LF026

#6 x 1-1/2" Lg. screw for fastening corner locker to filler

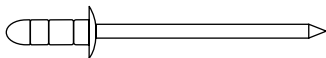

FAST-LF029

Black multi-grip rivet for number plate on standard lockers

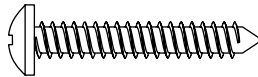

FAST-LF041

#8 x 1-1/4" Lg. screw for fastening slope top to locker



FAST-LF006

#6 x 5/8" Lg. screw for end panel mounting

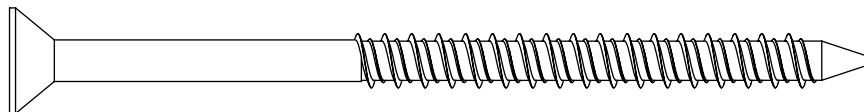
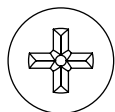

FAST-LF032

1/4" x 5" Lg. Tapcon screw for island locker floor mounting

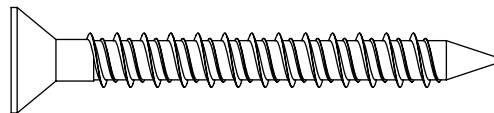
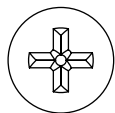

FAST-LF042

1/4" x 2-1/4" Lg. Tapcon screw for securing slope top to concrete wall

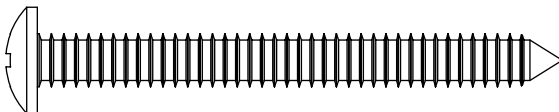

FAST-S359

1/4" x 2-1/2" Lg. screw for securing slope top to wood or steel-studded wall

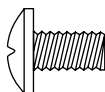

FAST-LF030

#10-24 sex bolt for filler mounting

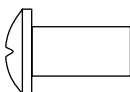

FAST-LF044

#10-24 x 1/2" sex bolt for filler mounting

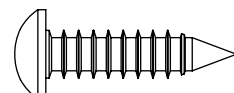

FAST-P005

#10 x 3/4" Lg. T-25 security screw for locker mounting

Installation Instructions

Step 1: Optional Locker Base Installation

⚠ IMPORTANT: Make sure the base is square AND level before anchoring to the floor (the base may be square but not level so be sure to check both). This will ensure proper locker operation.

NOTE: The base sections are shipped in standard lengths and come with slotted end caps. The length of the base sections can be easily modified during installation by cutting one end to the desired length. DO NOT cut the end caps.

1. Measure and scribe placement lines for the locker base sections.
2. Position the base sections per submittal layout. The ends of the base sections fit into the slots in the end caps (see Figure 1). Square and plumb the sections and end caps using shims as required. If shims are used, place them under the mounting brackets perpendicular to the bracket.
3. For longer locker runs, the base sections may need to be connected together. Use the mending plate and #10 x 1/2" screws provided to connect pieces (see inset, Figure 1).
4. Using the applicable mounting hardware supplied, anchor the base sections to the floor. Use a 3/16" masonry drill bit for 1/4 x 1-3/4" Tapcon screws (see inset, Figure 1).

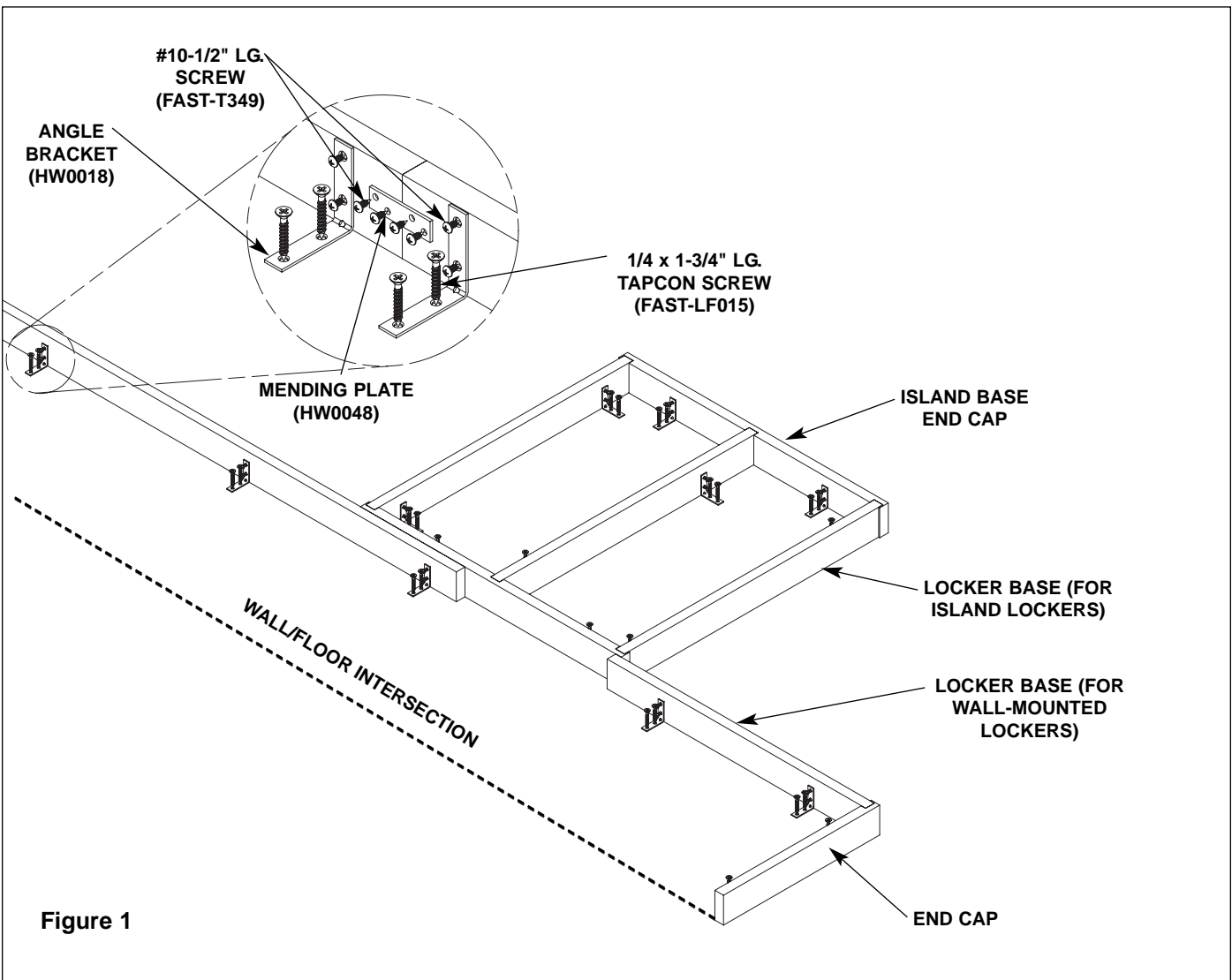

Figure 1

Installation Instructions *continued* . . .

Step 2: Optional Corner Filler Installation

NOTE: Corner fillers are designed to fill gaps in corners (a corner filler is shown in Figure 3a on page 6). They are attached to the locker with the #10-24 male and #10-24 x 1/2" female sex bolts provided.

NOTE: Be sure to attach the filler to the proper side of the locker per your submittal layout.

1. Align the filler to the locker top and front and temporarily clamp in place.
2. Using the holes in the filler as a template, drill four 9/32" dia. holes through the locker as shown in Figure 2.
3. Secure the filler to the locker with the #10-24 male and #10-24 x 1/2" female sex bolts provided.

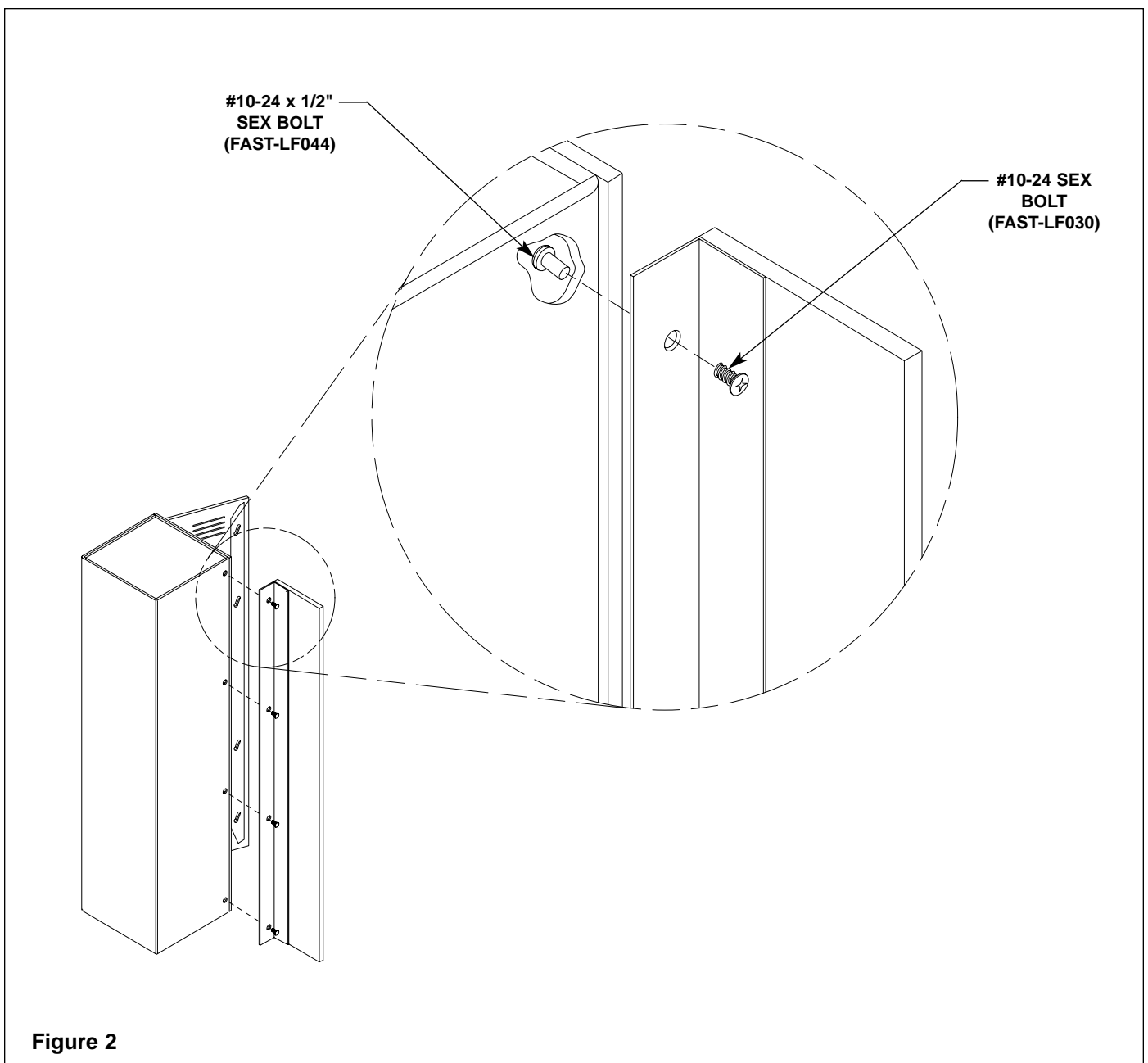

Installation Instructions *continued* . . .

Step 3: Locker Installation

NOTE: Refer to your submittal layouts for proper locker position. The first locker is usually installed at a corner or at the end of a run.

IMPORTANT NOTE FOR STANDARD LOCKERS: Make sure each locker is square AND level before securing into place (the lockers may be square but not level so be sure to check both). Use shims as needed.

1. Position the first locker according to your submittal layouts. Square and plumb the locker using shims as required. Secure the locker to the wall in two places with the two 1/4" x 1-3/4" Lg. Tapcon screws (for concrete walls) or two #14 x 1-3/4" Lg. screws (for stud walls). With the screws centered across the width of the locker, place one near the top and one near the bottom as shown in Figure 3.
2. Position the second locker next to the first locker. STANDARD LOCKERS ONLY: Square and plumb the locker using shims (as required) to align the tops and fronts.

IMPORTANT: Lockers must be installed flush with adjacent lockers.

3. Temporarily clamp the lockers together at the top and bottom. Drill four 9/32" clearance holes through one locker as shown in Figure 3. The holes should be located 1-1/2" from the front of the locker and evenly spaced, top to bottom. Fasten lockers to each other using the #10 x 3/4" T-25 security screws provided.
4. Position additional lockers according to your submittal layouts. Square and plumb each locker using shims as required. Fasten lockers to each other using the #10 x 3/4" T-25 security screws provided.
5. Secure each locker to the wall in two places with the appropriate wall installation hardware provided. Use two 1/4" x 1-3/4" Lg. Tapcon screws for concrete or two #14 x 1-3/4" Lg. screws for studs, placing one near the top and one near the bottom of the locker as shown in Figure 3.

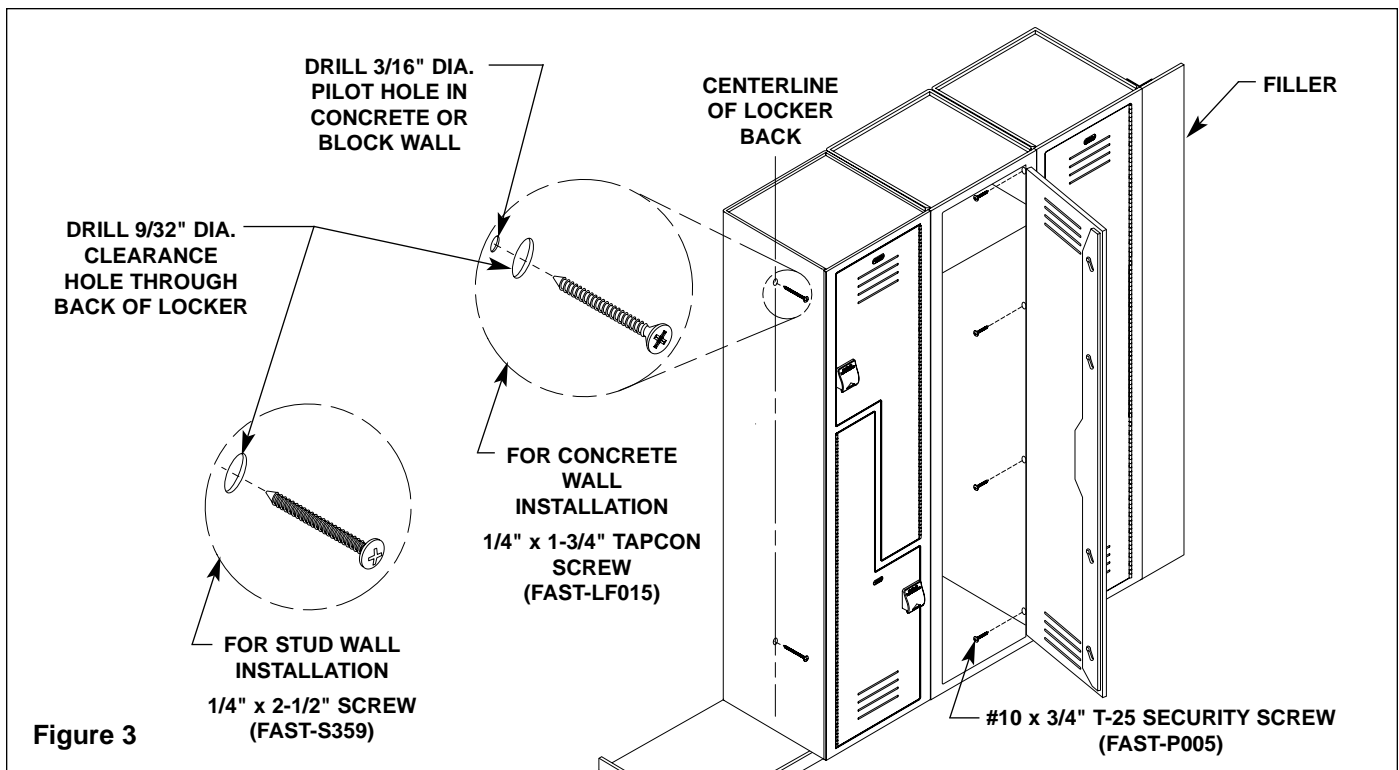
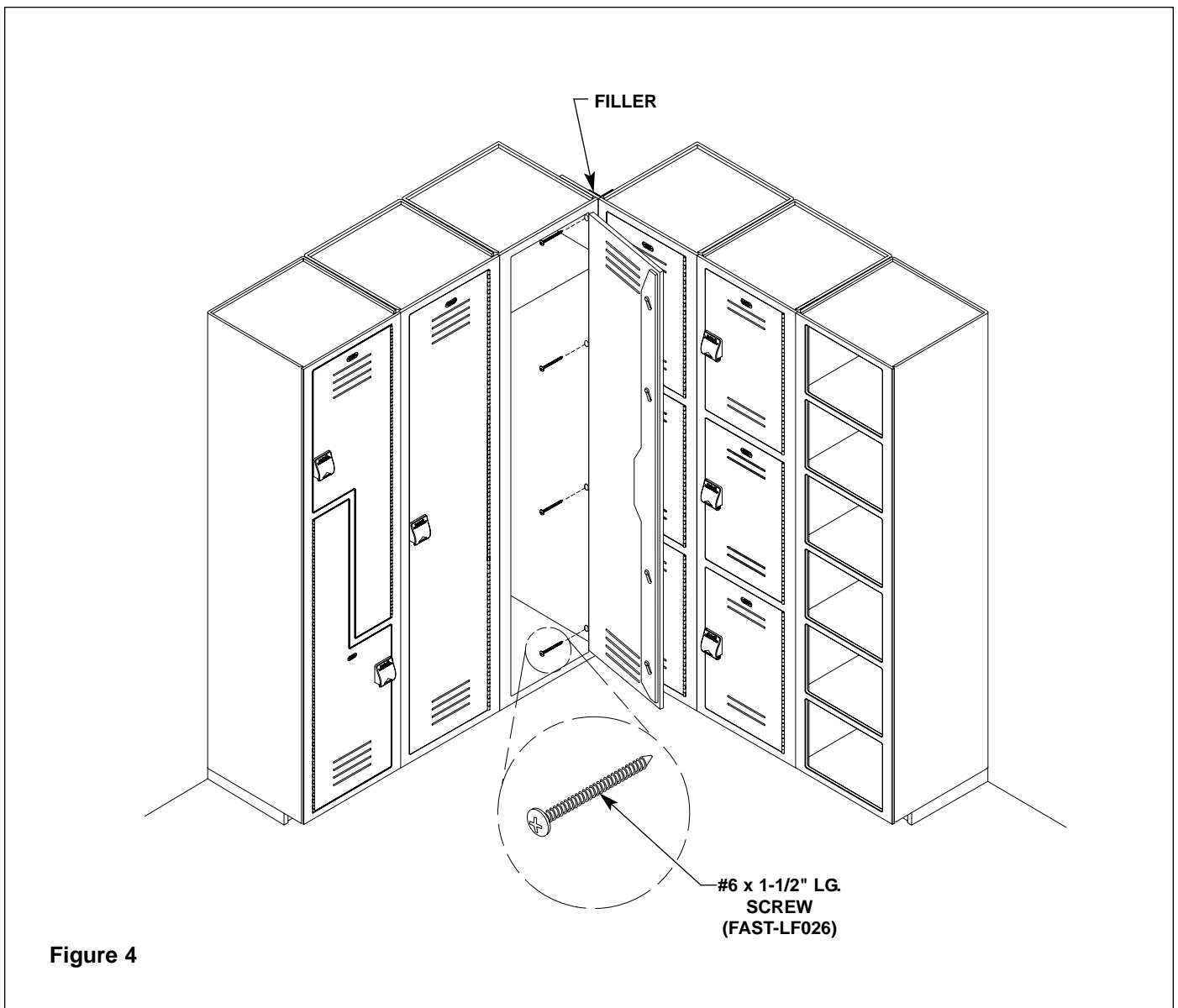

Figure 3

Installation Instructions *continued . . .*

Step 4: Corner Locker Installation

1. Drill four 3/16" dia. clearance holes 1-1/2" from the locker face through the locker box only (see Figure 4). Fasten the locker to the corner filler with the #6 x 1-1/2" screws provided.
2. Secure each locker to the wall in two places with the appropriate hardware provided. Use two 1/4" x 1-3/4" Lg. Tapcon screws for concrete or two #14 x 1-3/4" Lg. screws for studs, placing one near the top and one near the bottom of the locker (refer to Figure 3a on page 6).
3. Position the additional lockers according to the submittal layouts. Square and plumb each locker using shims as required. Fasten the lockers to each other using the #10 x 3/4" T-25 security screws provided.
4. Secure each locker to the wall in two places with the installation hardware provided. Use two 1/4" x 1-3/4" Lg. Tapcon screws for concrete or two #14 x 1-3/4" Lg. screws for studs, placing one near the top and one near the bottom of the locker (see Figure 3a on page 6).



Installation Instructions *continued* . . .

Step 5: Optional End Filler Installation

NOTE: Fillers are designed to fill gaps between locker runs. They are cut to size by the installer and attached with 3-4 suitable fasteners supplied by the installer. The fillers are attached to either an adjoining locker or blocking (the blocking provides support at the end of a locker run). If fillers are being attached to a wall, attach the blocking to the wall first, then secure with suitable fasteners (blocking and fasteners are supplied by installer). Make sure the blocking is positioned so that the filler will be flush with the face with the locker.

NOTE: Be sure to attach the filler to the proper side of the locker per your submittal layout.

1. Cut the end locker filler to size.
2. Align the filler to the locker top and front and temporarily clamp in place.
3. Using the holes in the filler as a template, drill four 9/32" dia. holes through the locker (refer to Figure 2 on page 5).
4. Secure one side of the filler to the locker with the #10-24 male and #10-24 x 1/2" female sex bolts provided.
5. Secure the other side of the filler to the blocking (fasteners provided by installer).

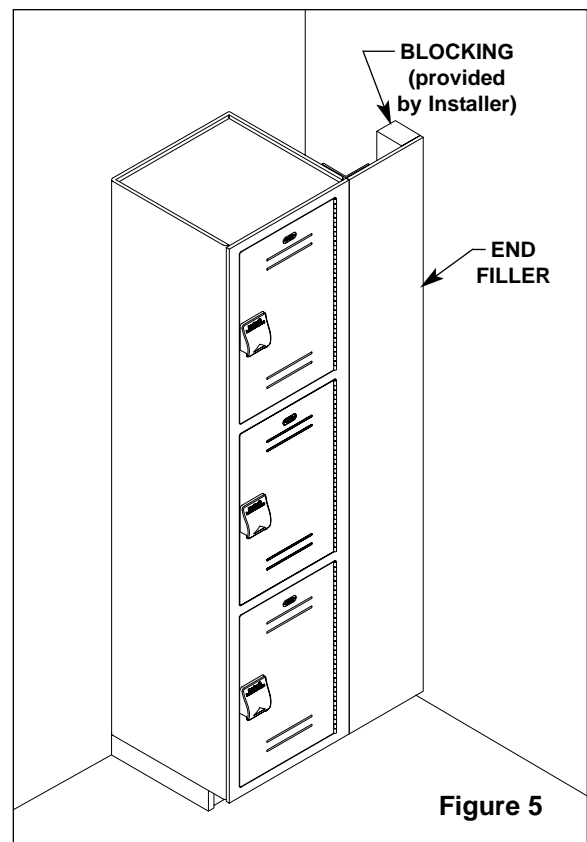

Figure 5

Step 6: Number Plate Installation

NOTE: Installation of the number plate is for a standard or "Z" locker only. Cubby locker does not have a number plate.

1. Determine the locker number sequence.
2. Position the number plate in the recess in the locker door (see Figure 6).
3. Hold the plate in place with your finger and, using a pop rivet gun, install the two rivets into the plate from the front of the locker.

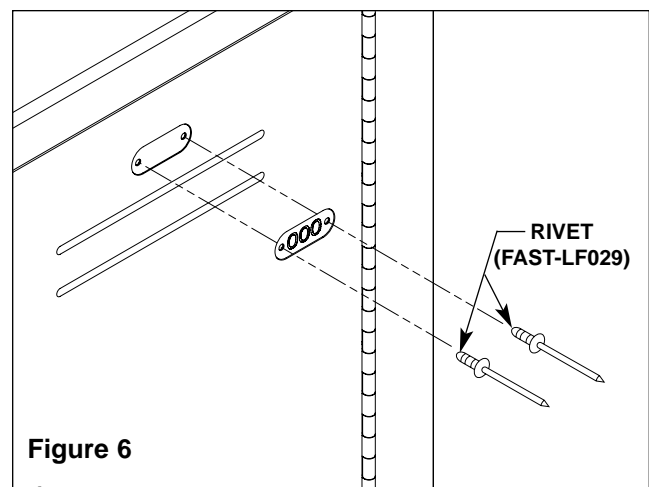

Figure 6

Installation Instructions *continued* . . .

Step 7a: Optional Locker Slope Top Installation

NOTE: Standard 3-tier lockers are shown in Figures 7a–7e. Slope and flat tops for Cubby and "Z" lockers are similar.

NOTE: The slope tops are shipped in standard lengths and can be easily modified during installation. This modification is often necessary to overcome a variety of installation situations. Use a panel saw to cut the slope top sections to the proper length if necessary.

NOTE: Use the corner slope top in the corner as shown in Figure 7c on page 10.

NOTE: Corner slope tops should only be trimmed when they extend past the edge of the locker.

NOTE: Wall strips will be 54" maximum length. Color of wall strips may vary.

1. Drill the appropriate number of 3/16" dia. clearance holes through the top of the installed lockers, **making sure that the holes are located 1-1/4" from the front edge of the locker. This dimension is critical to ensure proper installation (see Figure 7a).**

- Locker screw hole requirements: slope tops less than 18" long, two holes; 18"–35" long, three holes; 36"–45" long, four holes; 72" long, six holes.

2. Position the wall strip (or strips) on top of the lockers flush against the wall as shown in Figure 7b. Measure, scribe and drill 1/4" mounting holes into the wall strip as follows:

- **CONCRETE/BLOCK WALLS:** Start 1" from each end and space holes equally (do not exceed 16" on centers). The holes must be located at least 1-1/4" from the bottom edge of the wall strip. Use a 3/16" masonry drill bit and 1/4 x 1-3/4" Lg. Tapcon screws to anchor the wall strip to the wall.
- **STUD WALLS:** Drill the mounting holes at every stud location covered by the wall strip. The holes must be located at least 1-1/4" from the bottom edge of the wall strip. Anchor the wall strip to the wall with #14 x 1-3/4" Lg. pan head screws.

Locker slope top installation instructions continue on page 10.

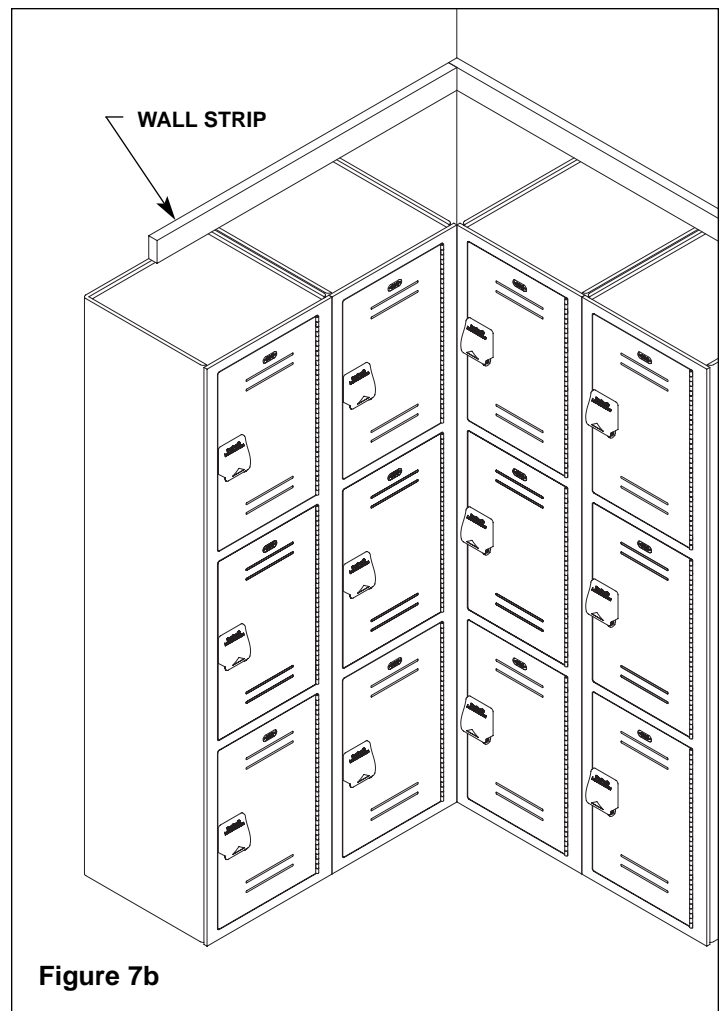
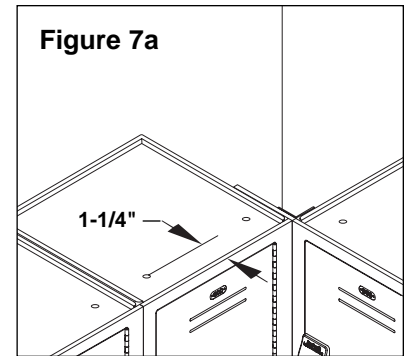

Installation Instructions *continued* . . .

Step 7a: Slope Top (cont'd.)

3. If a corner slope top is being installed, position that slope top first. Fit the groove of the slope top over the front edge of the locker while at the same time pressing down on the score line of the slope top as shown in Figure 7c. Rest the back edge of the corner slope top onto the wall strip.
4. Fit the groove of the next slope top section over the front edge of the locker as shown in Figure 7c. Rest the back edge of the slope top section onto the wall strip.
5. Secure the slope top to the locker with the #8 x 1-1/4" Lg. screws provided (see Figure 7c). Do not overtighten screws.

NOTE: If desired, caulk the gap in the back edge of the slope top where it meets the wall strip.

6. Measure, modify and install the remaining slope tops for a custom fit.

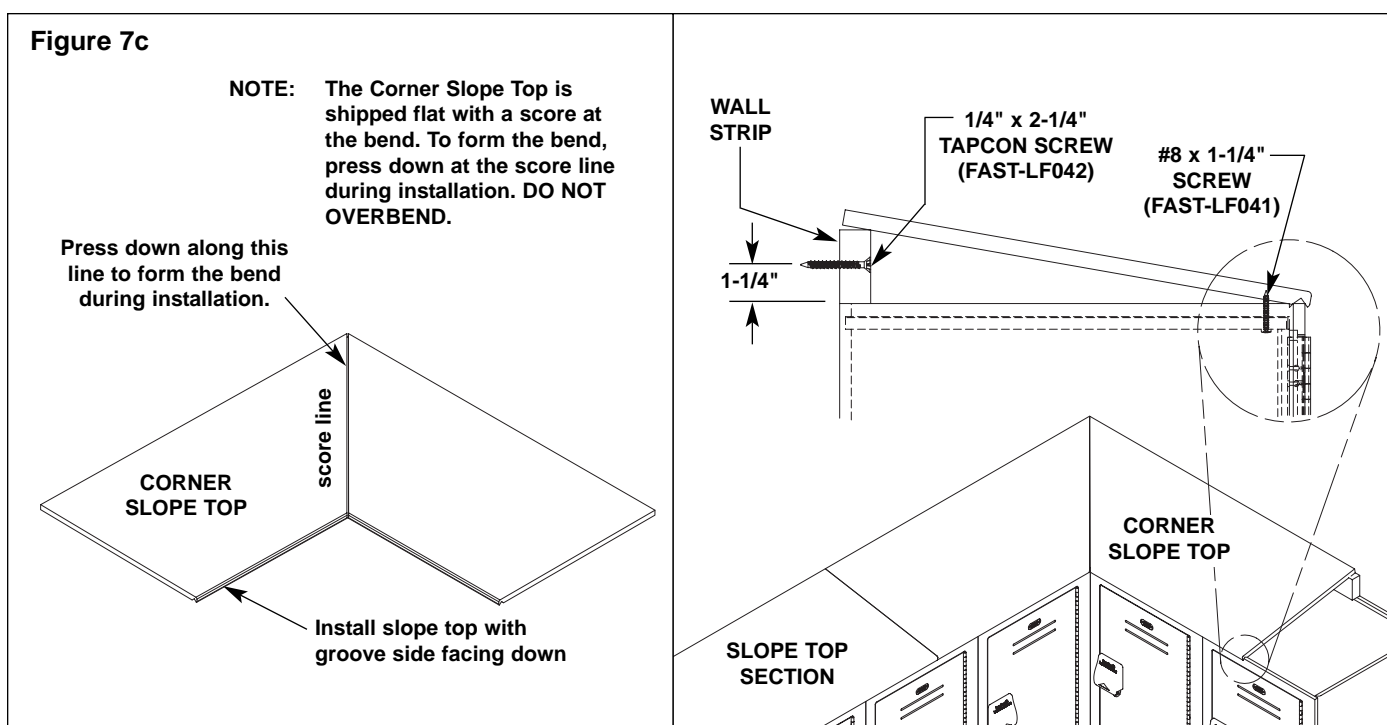

Installation Instructions *continued* . . .

Step 7b: Optional Locker Flat Top Installation

NOTE: The flat tops are shipped in standard lengths and can be easily modified during installation. This is often necessary to overcome a variety of installation situations. Use a panel saw to cut the flat top sections to the proper length if necessary.

1. Drill the appropriate number of 3/16" dia. clearance holes through the top of the installed lockers equidistant from locker front to back (see Figure 7d).
 - Locker screw hole requirements: flat tops less than 18" long, two holes; 18"–35" long, three; 36"–45" long, four; 72" long, six.



IMPORTANT: To prevent injury, make sure the radiused edge of the flat top is facing the front of the lockers, and the sharp edge is facing the back of the lockers.

2. Starting at the corner and working outward, secure the flat top to the locker with the #8 x 1-1/8" Lg. screws (provided by installer) (see Figure 7e). Do not overtighten screws.

NOTE: If desired, caulk the gap in the back edge of the flat top where it meets the wall.

3. Measure, modify and install the remaining flat tops for a custom fit.

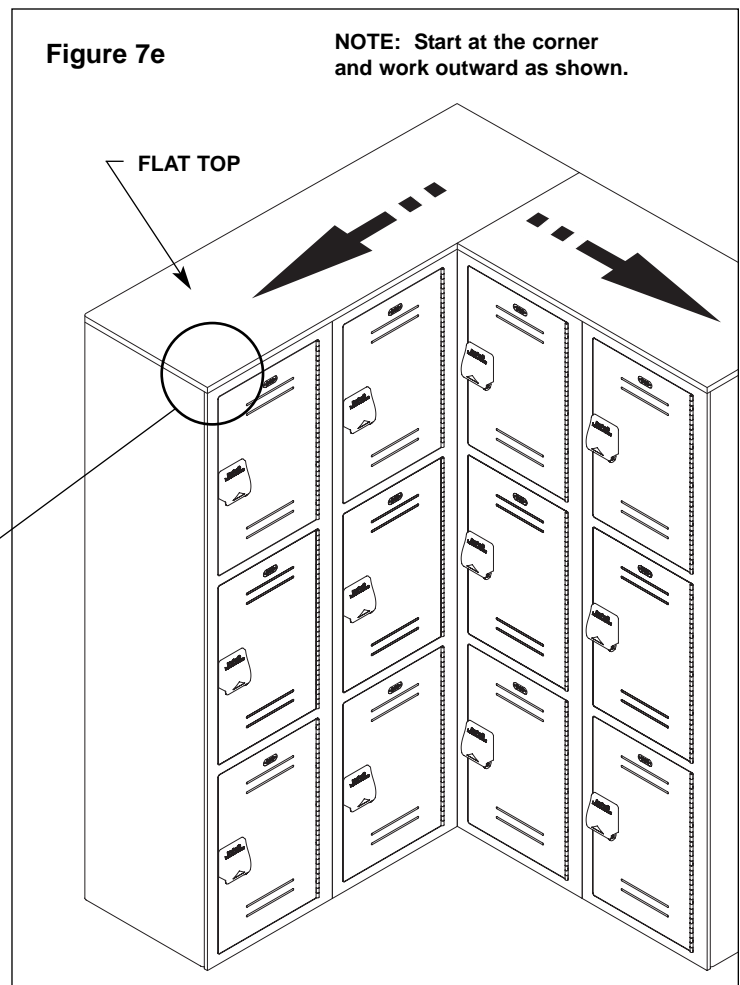
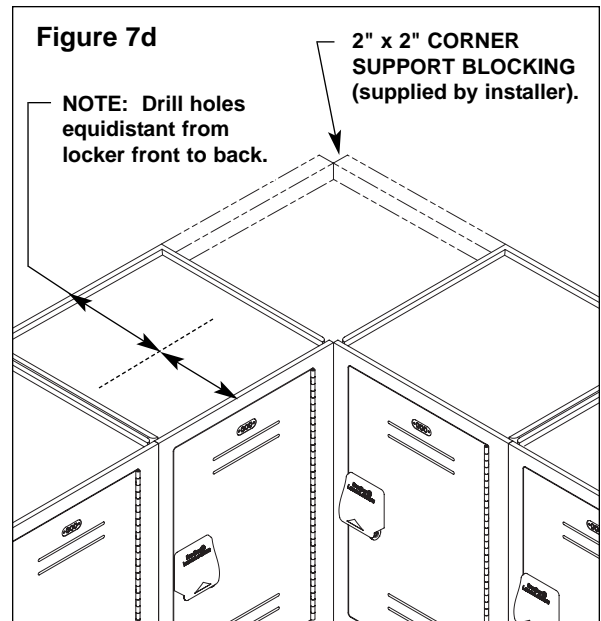

Installation Instructions *continued* . . .

Step 8: End Panel Installation (optional)

NOTE: Optional slope top not shown in Figure 8.

NOTE: The end panels can be cut to size with a panel saw if necessary. Only the front edge has a radius and should not be cut.

1. Drill five 3/16" dia. holes through each of the exposed locker side(s) where the end panel is to be attached at the locations shown in Figure 8. Do not drill holes into the end panel.
2. Fasten the end panel to the locker(s) using the #6 x 5/8" screws provided (see Figure 8). The screws must be inserted through the inside of the locker and screwed into the end panel. The screws will not protrude through the end panel.

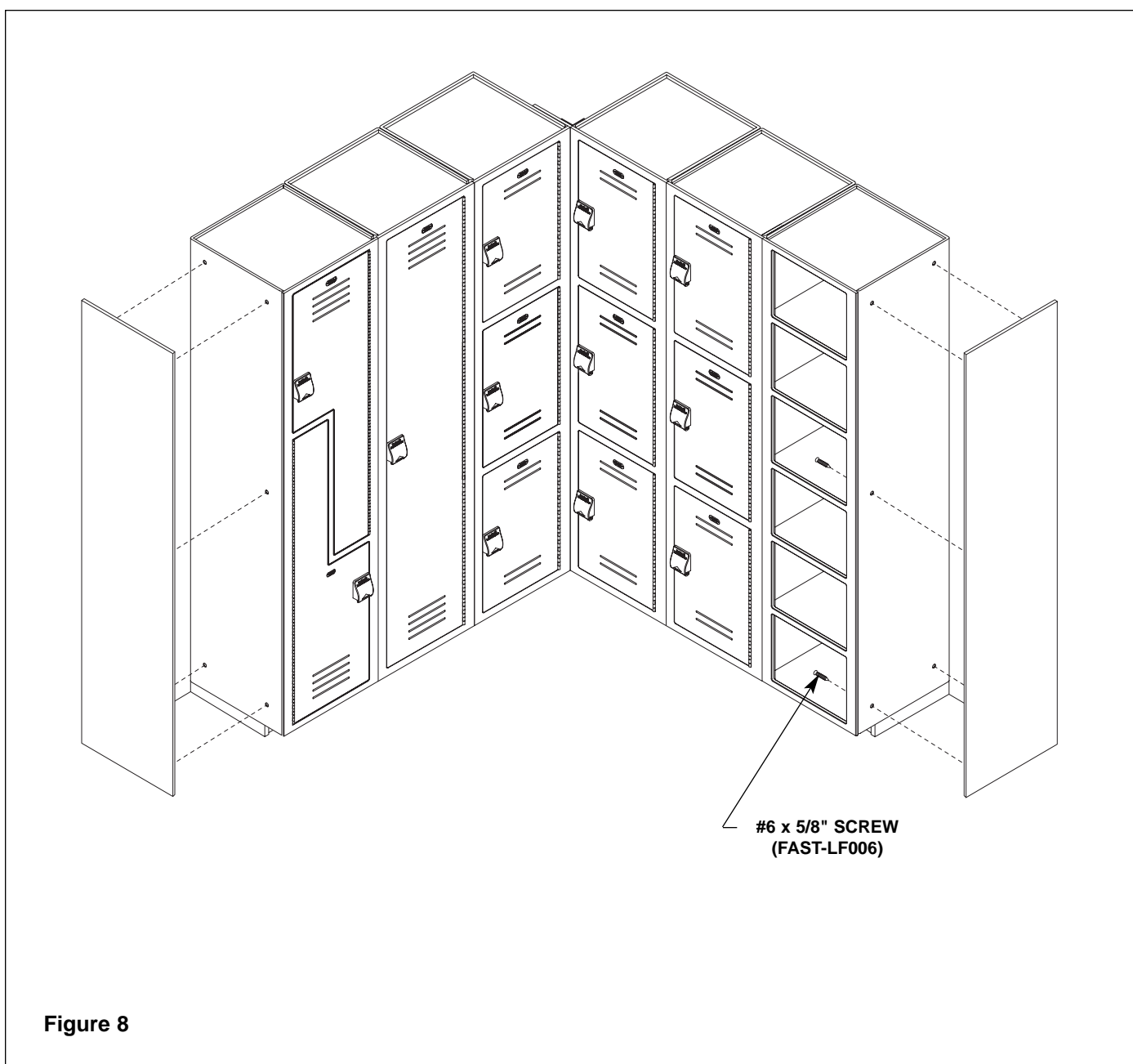

Installation Instructions *continued* . . .

Step 9: Back-To-Back Locker Installation

NOTE: Back-to-back locker installation is similar to standard installation. The base sections must be square and plumb prior to installing lockers.

1. Anchor the base sections to the floor using the hardware supplied (refer to Step 1 on page 4).
2. Fasten fillers to the corner lockers (refer to Step 2 on page 5).
3. Position, square and plumb the lockers onto the base, making sure locker tops and fronts are flush. Temporarily clamp the adjoining locker sides together at the top and bottom. Drill four 9/32" holes through one locker. The holes should be located 1-1/2" from the front of the locker and evenly spaced from top to bottom (refer to Figures 3a and 3b on page 6 if necessary).
4. Drill four 9/32" holes through one adjoining locker back (see Figure 9). Fasten the lockers together using the #10-3/4" screws provided.

NOTE: Island locker installation requires floor mounting in addition to locker-to-locker attachment.

NOTE: For concrete floors, use a hammer drill with a six-inch long drill bit for pilot holes.

5. Drill a 3/16" pilot hole through the bottom of each locker into the floor. Use a drill with a six-inch long drill bit. The holes should be located near the front of the locker. Drill a 9/32" clearance hole through the bottom of each locker into the floor. Secure the lockers to the floor with the Tapcon screws provided.

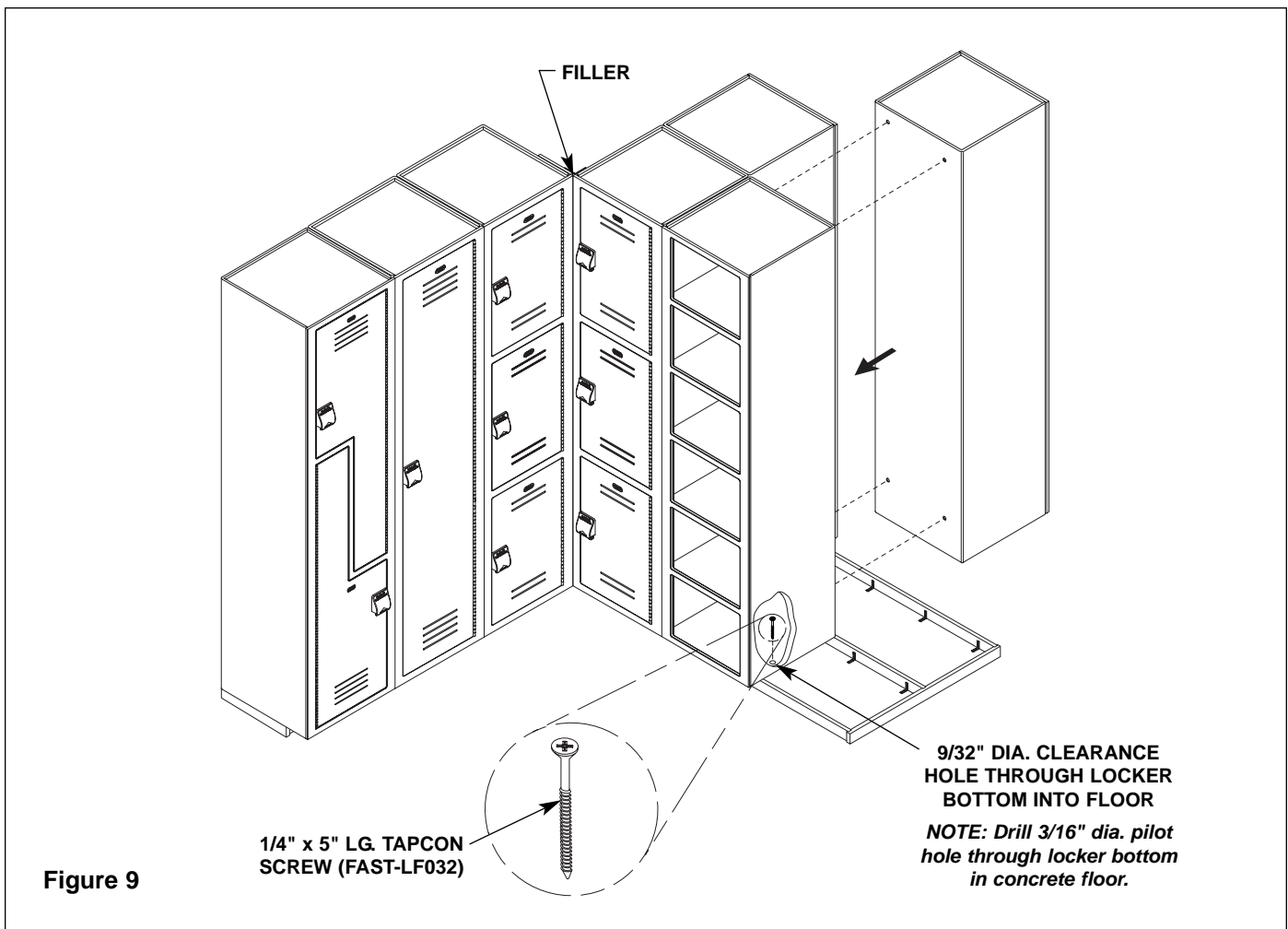

Installation Instructions *continued* . . .

Step 10: Back-To-Back Locker Slope Top Installation

NOTE: Mounting strips will be 54" maximum length. Color of strips may vary.

1. Drill 3/16" dia. clearance holes through the top of the installed lockers, making sure that the holes are located 1-1/4" from the front edge of the locker (see Figure 7a on page 9).
2. Position the slope top mounting strips on top of the lockers as shown in Figure 10a.
3. Temporarily clamp the slope top mounting strips together, making sure they are flush and aligned.
4. Using the 2" mounting brackets and hardware supplied, anchor the mounting strips to the top of the locker as shown in Figure 10a.
5. Position the slope top on top of the lockers as shown in Figure 10b on page 15, fitting the slope top groove over the edge of the locker.
6. Hold the slope top down tight against the top of the locker and secure with the #8 x 1-1/4" screws provided (see Figure 10b). Do not overtighten the screws.
7. Install the remaining slope top sections per the instructions outlined above.

NOTE: If desired, caulk the gap in the back edge of the slope top where it meets the wall strip.

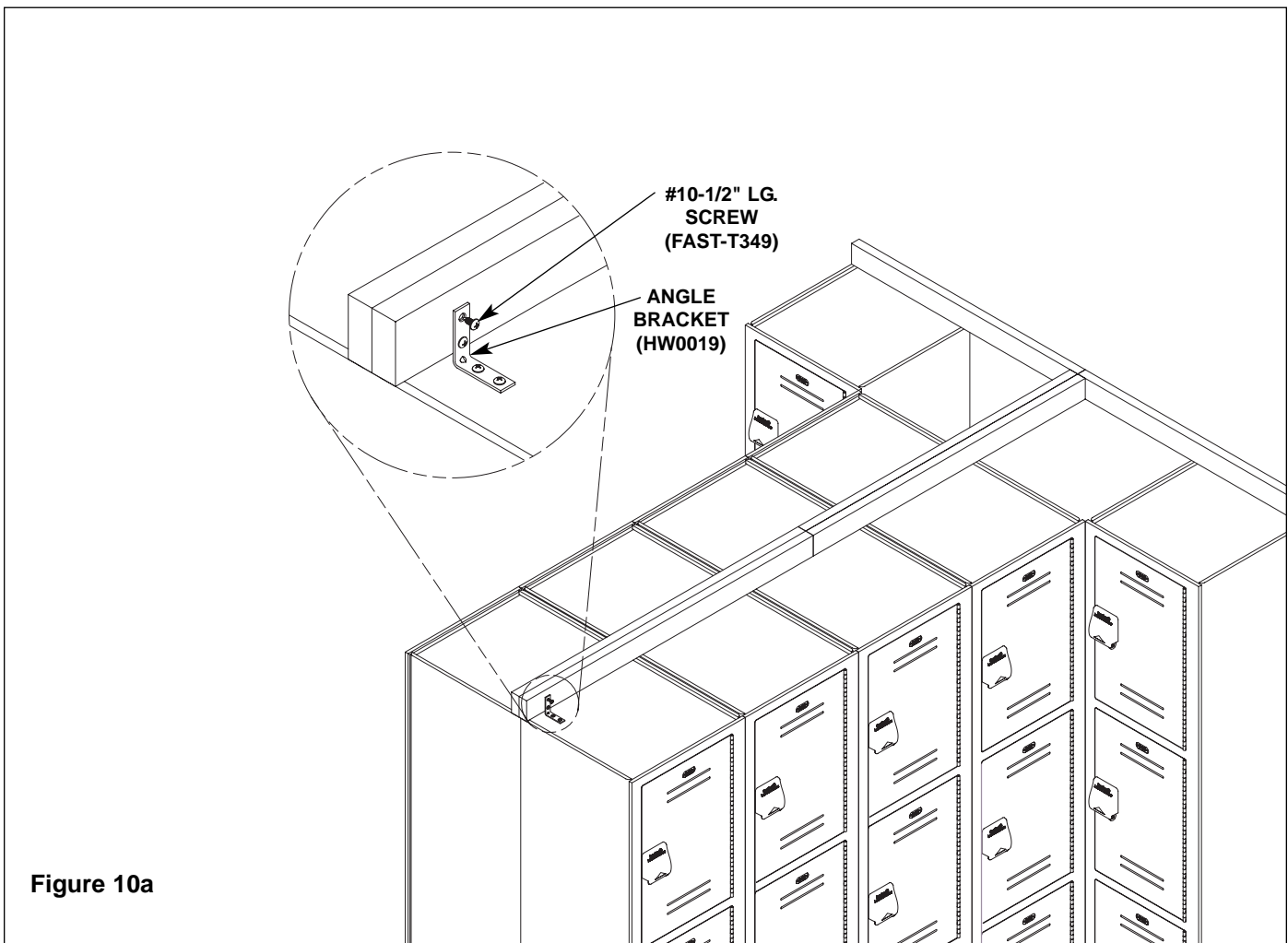

Installation Instructions *continued* . . .

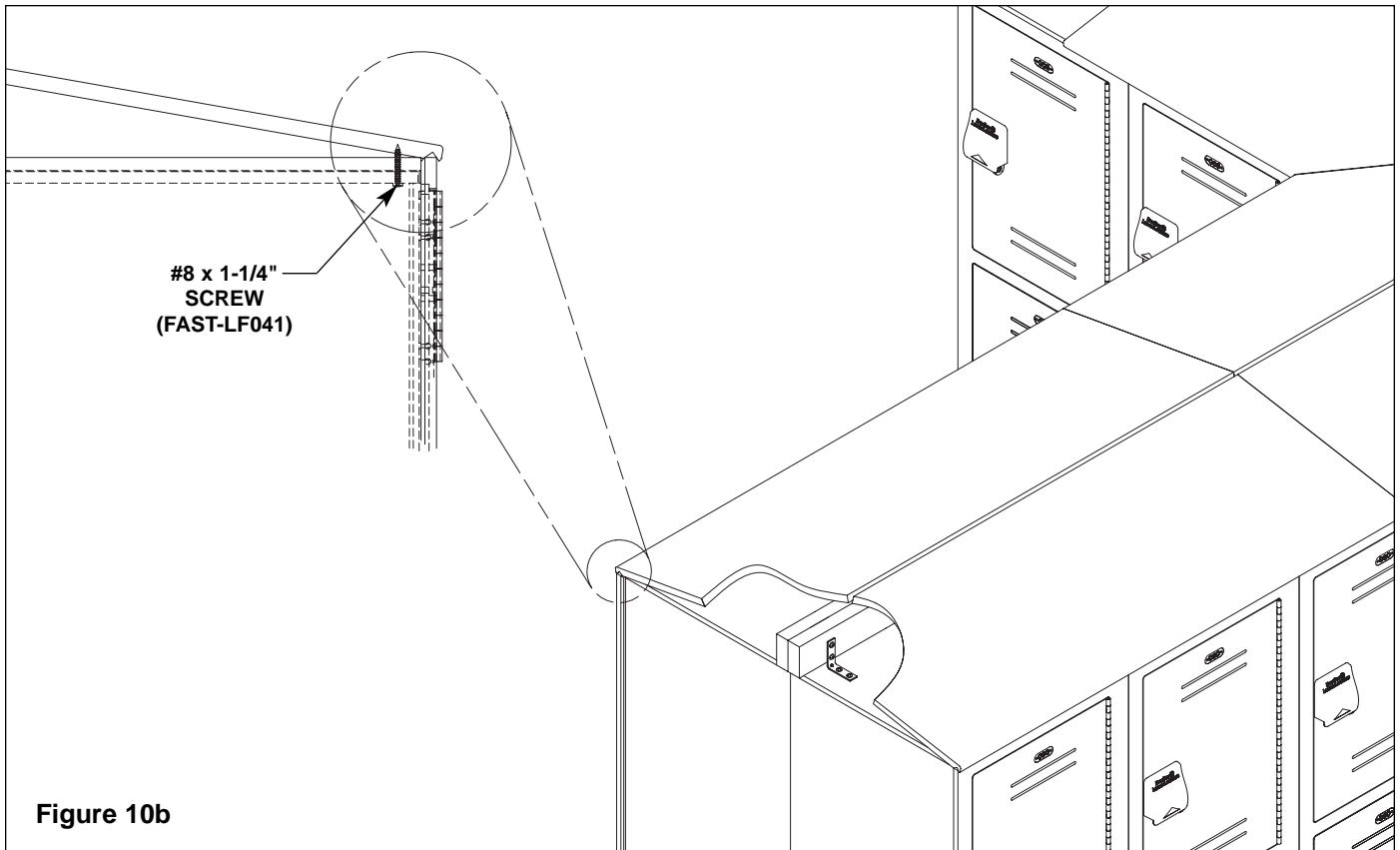

Step 11: Island End Panel Installation

1. Drill ten 3/16" dia. holes through each of the exposed locker sides where the end panel is to be attached. Do not drill holes into the end panel.
2. Fasten the end panel to the locker with the #6 x 5/8" screws provided (see Figure 11).

NOTE: The screws must be inserted through the inside of the locker and screwed into the end panel. The screws will not protrude through the end panel.

