

## 10 YEAR MANUFACTURER'S LIMITED WARRANTY

All parts of this Elements Of Design faucet are warranted to the original retail purchaser to be free from defects in material and workmanship for a period of ten(10) years from the date of purchase as shown on the purchaser's receipt. This warranty is limited to defective parts only, labor charges and/or damage resulting from improper installation, repair or replacements, as well as incidental and consequential damages connected therewith are excluded.

Any damage to this faucet as a result of misuse, abuse, neglect, accident for improper installation or any use not consistent with the instructions furnished by Elements of Design, will void this warranty. Replacement parts can be obtained from your local dealer.

### CAUTION!!!

1. Water lines must be completely flushed before use, to avoid bris & clogs in your water system leading to malfunction and reduction of water flow.
2. Warranty to be void if water lines are not flushed before use of new faucet.
3. Use of abrasives of any strength may damage the finish of your faucet and void this warranty.

CODE APPROVAL: LA#M-000018

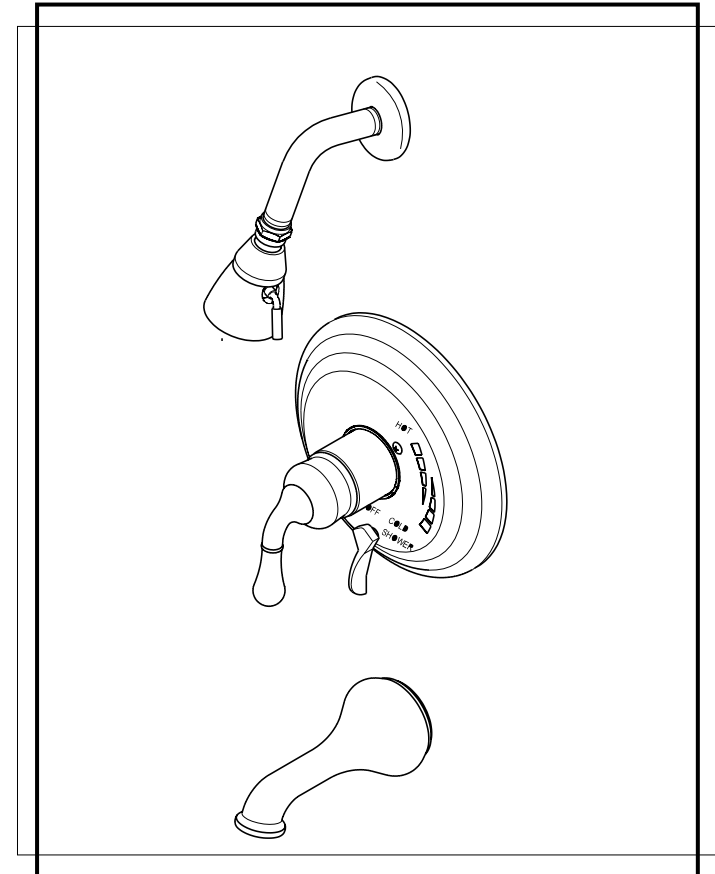

Elements  
Of Design

T 909.465.6687 F 909.548.6843 1877.FAUCET.1  
www.eodfaucet.com  
email: support@eodfaucet.com

## Back to Back installation instructions

In situations where the hot and cold water inlet supplies are not in the standard positions, a reversible type cartridge can be used. A reversible cartridge will allow you to modify the direction of the water supply to the correct orientation without changing the pipe locations. It is easy to change the installation by yourself by using the following instruction.

**NOTE : FLUSH ALL PIPING THOROUGHLY BEFORE INSTALLATION .**

Teflon tape or pipe joint compound on all threaded connections are required .  
**SHUT OFF THE WATER SUPPLY VALVES BEFORE INSTALLATION .**

Tools required for installation of this product are :

- ◇ Screw Driver
- ◇ Tubing Cutter
- ◇ Teflon Tape
- ◇ Adjustable Wrench
- ◇ Channel-lock Pliers
- ◇ Measuring Tape

Figure 1 :

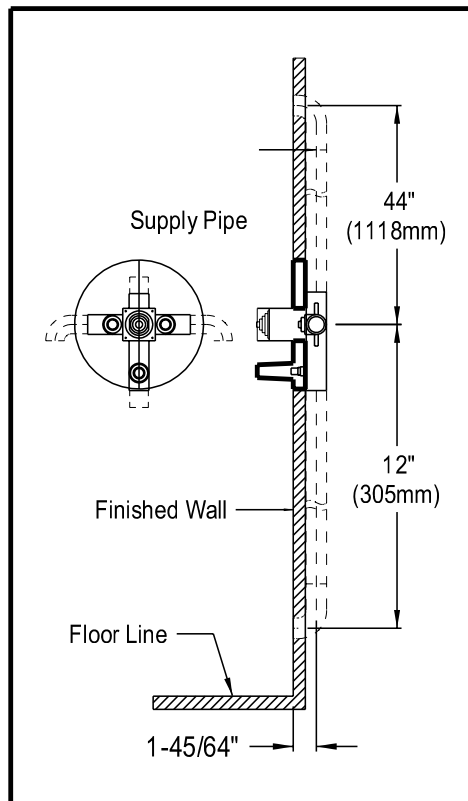
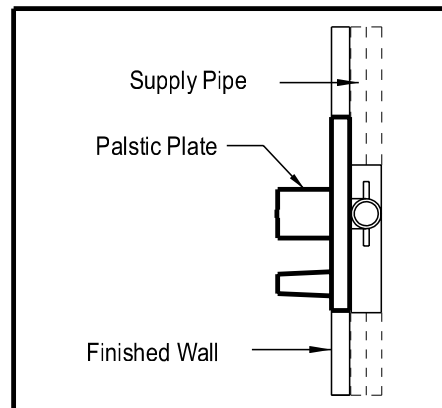

Figure 1A :



Step 1 :

Install piping and fittings with valve body as shown in Figure 1.

**IMPORTANT :** Valve rough-in is  $1 \frac{45}{64}$ "  $\pm 1/2$ " from CENTERLINE OF SUPPLIES TO FACE OF FINISH WALL.

Facing front of valve body connect hot water to left side and cold water to right side .

The valve has "up" and "down" cast into the back of body .Position "up" to the shower and "down" to the tub .

Install so that line indicated on plastic plate on valve is flush with finished wall as shown in Figure 1A .

Figure 2 :

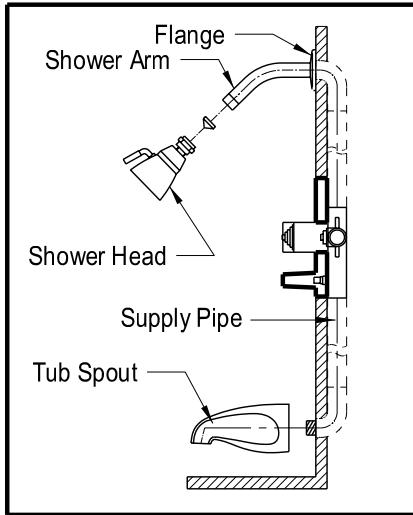

Step 2 :  
Measure the length of pipe from the valvebody to the shower arm opening. Connect the pipe to the top thread of the valve body. Slip the flange onto the shower arm and connect shower arm to the supply pipie. Please see Figure 2 .

Figure 3 :

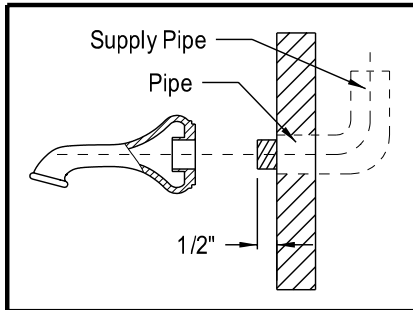

Step 3 :  
Measure the length of pipe from the valve body to the tub spout opening. Connect the pipe to the end thread of the valve body. The length of the pipe connecting the spout and supply pipe will be different because of different model number. Please see Figure 3. Wrap Teflon tape on threads of the pipe and thread the tub spout onto the wall .

Figure 4 :

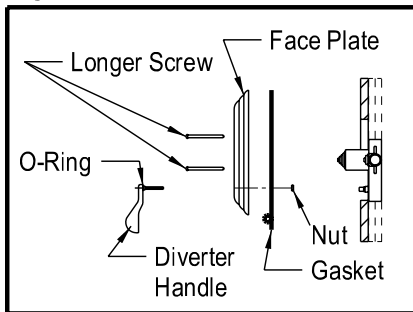

Step4 :  
Unscrew the screws on the plastic plate and remove the plastic plate. Mount gasket onto the back of face plate. Install the diverter handle into the diverter hole of the face plate. Secure the diverter handle by threading the nut onto the face plate as illustration. Position the face plate onto the valve body and thread the longer screws provided tight. Please see Figure 4 .

Figure 5 :

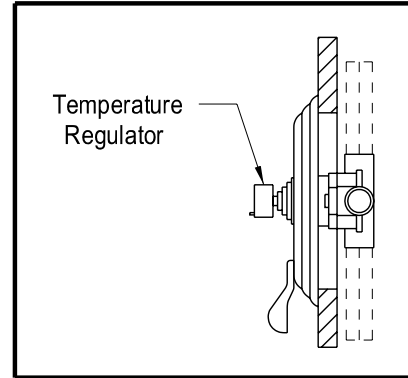

Step 5:  
Reset the temperature regulator on the position you would like the temperature to be. Turn on the water supply valves to make sure the temperature suits your requirement. When water is running ,check for any leaks for drip. Tightening connections as necessary . Please see Figure 5.

Step 7 :  
After installation is completed ,turn on the hot and cold water supply valves fully for three minutes .Check for any leaks or drips . Tighten connections as necessary .

Figure 6 :

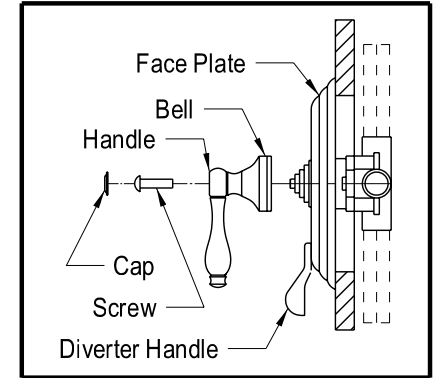

Step 6 :  
Thread the bell onto the stem of the valve body .Install the handle onto the bell and secure it by threading the allen screw . Please see Figure 6 .

