

# Assembly Instructions For **FM369** (E) 1/12

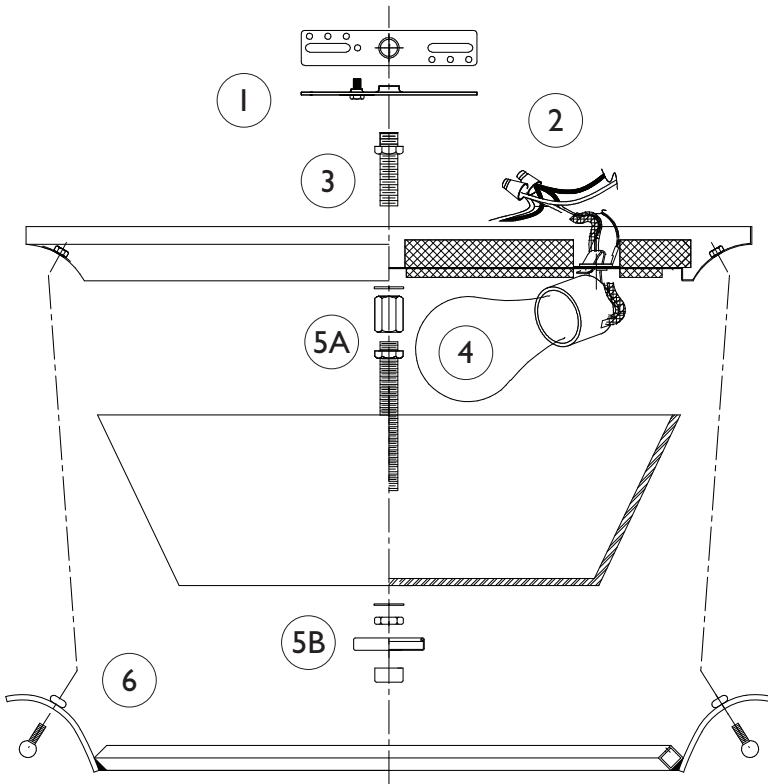

**IMPORTANT**  
**TURN OFF THE POWER AT THE MAIN FUSE OR**  
**CIRCUIT BREAKER BOX**  
**BEFORE STARTING INSTALLATION**

Carefully unpack and identify all parts before assembly. Bulbs not included.

1. Install mounting strap:
  - A. Gently pull supply wires out from outlet box.
  - B. Install mounting strap onto the outlet box using two screws supplied with outlet box. **NOTE:** The side with green grounding screw head must face away from the outlet box.
  - C. Install threaded pipe by screwing onto center of mounting strap.
  - D. Test install fixture plate to make certain about 3/8" (8mm) of thread protrude outside of fixture plate. If not then remove fixture plate and adjust threaded pipe length accordingly. Secure threaded pipe length by fastening with hex nut. Make certain not to spin pipe during fastening. Place fixture plate aside.
  - E. Spread electrical wires so that black wires are on one side of the outlet box and the white wires are on the other side.
2. Connect electrical wires:
  - A. Connect white fixture wire(s) to white supply wire from outlet box with wire connector. Connect black fixture wire(s) to black supply wire from outlet box with wire connector. **NOTE:** Black outlet box wire may be red, round and smooth and/or have copper conductor. White outlet box wire may be square and ridged and/or have a silver conductor.
  - B. Connect fixture ground wire (without plastic insulation) to ground wire from outlet box (usually with green insulation) with wire connector. **Note:** If there is no supply ground wire at outlet box then attach fixture ground wire securely onto green grounding screw located at mounting strap. **IMPORTANT:** Never connect ground wire to black or white supply wires (from outlet box).
3. Install fixture plate. While carefully tucking all electrical wires inside of fixture plate, install the fixture plate onto the mounting strap by fastening with hex nut and then cap nut.
4. Install light bulb (not included). See relamping label at socket area for type and maximum allowed wattage.
5. A. Screw the long threaded pipe into coupler located at bottom of socket assembly. Note correct position of threaded pipe at illustration.  
B. Slip shade through the threaded pipe until it securely checks into bottom of fixture plate. Then secure into position by fastening with washer, hex nut, cap and finial. **IMPORTANT: DO NOT OVER TIGHTEN.**
6. Then secure ring onto fixture plate by fastening with cap nuts.