



16004-15



INSTRUCTIONS FOR YOUR NEW REMOTE FAN CONTROL SYSTEM

CAUTION: To reduce the risk of electric shock, install only in Fan

1. Model CD-52, manufactured by Ja Yang (E106510)
2. Model 9701, manufactured by Furn Fan (E141261)
3. Model AC-552, manufactured by Air Cool (E75795)

CAUTION : FOR CONTROL OF SHADE POLE, PERMANENT SPLIT CAPACITOR, OR UNIVERSAL MOTORS ONLY.

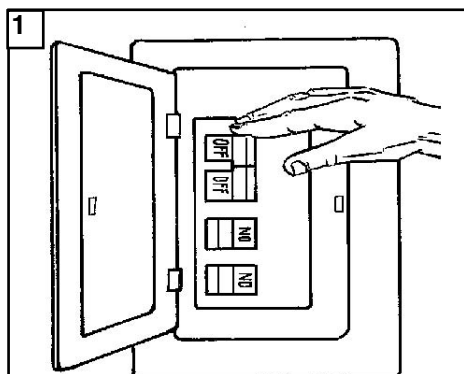

Caution: Turn off power at fuse box to avoid possible electrical shock.

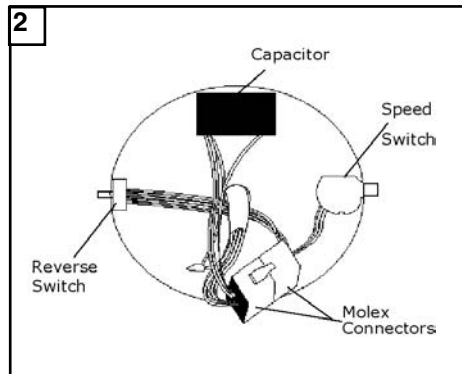

Top view of switch housing plate.

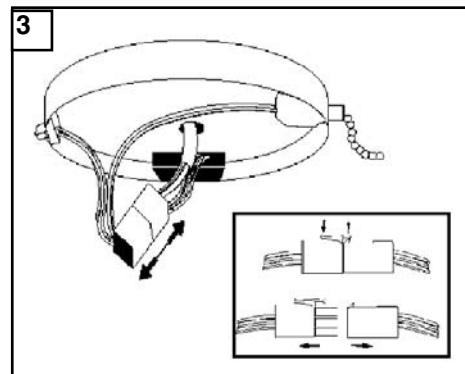

Disconnect Molex Connectors in switch housing plate by pushing down on tab and pulling the two (molex connectors) apart.

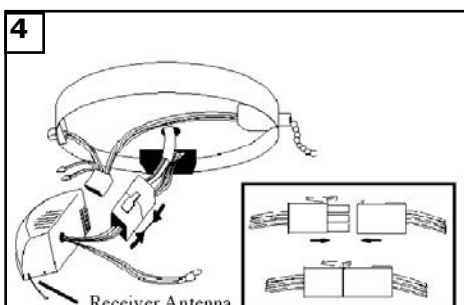

Connect the molex from the receiver to the molex in the switch housing plate by aligning and sliding together. Note: For longer distance operation, coil receiver antenna around the natural wire (white wire).

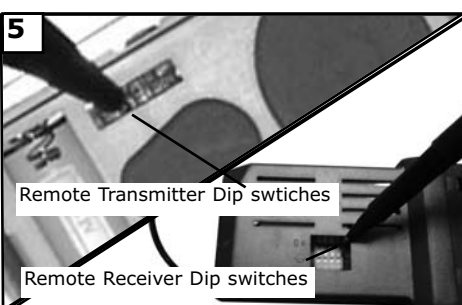

Set dip switches on the Remote Transmitter and Remote Receiver to the same settings. This must be done so the units will communicate properly. If you have other fans you can set to control from one transmitter by setting both receivers the same as the transmitter. If you have more than one fan with remote. You can set the dip switches to different positions to have separate control.

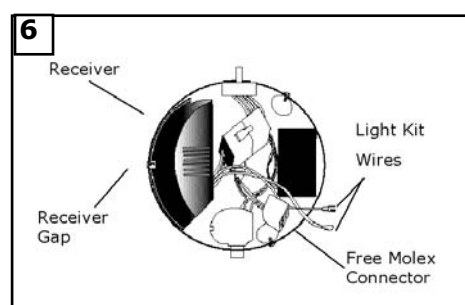

Align gap in receiver with the screw and slide receiver (Dip switch facing housing plate) into switch housing plate. Receiver should fit directly into area in the switch housing plate. Note: If installing light kit, use the blue and white wire from the receiver.



The wall control transmits the command signals via radio waves to the receiver installed in the fan's hanging bracket or on the fan. The receiver is required for the wall control to function. Power for the wall control comes from the 12V battery located in the wall remote. Duracell MN21 / Eveready A23 / GP 23A all 12V.

The frequency switches (dip switches) on the wall control and the receiver have been preset at the factory. Please recheck to make sure the switches on the wall control and receiver are set to the same position. Any combination of settings are fine as long as the wall control and ceiling fan receiver are set to the same position.

CAUTION: TURN OFF POWER AT FUSE BOX TO AVOID POSSIBLE ELECTRICAL SHOCK.

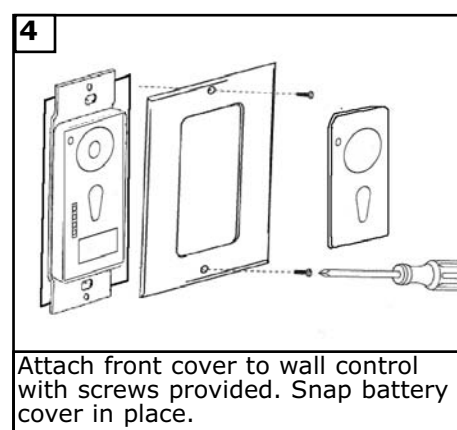
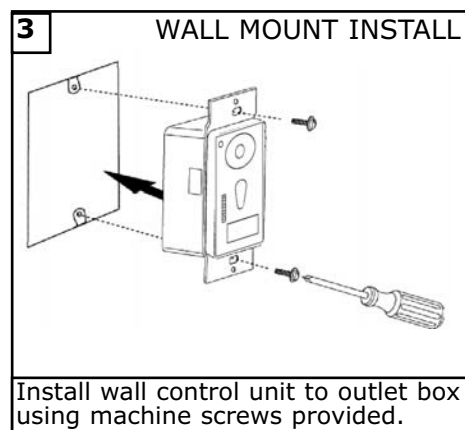
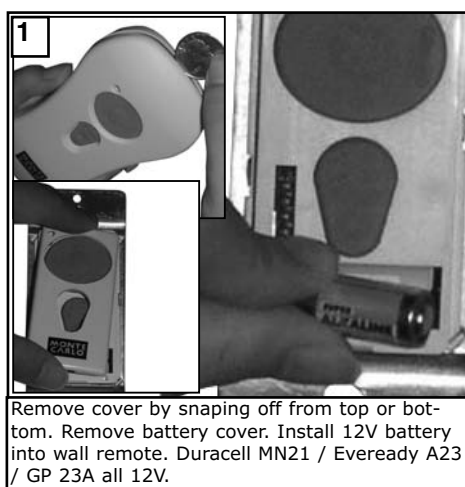



Remote Control Transmitter Features:

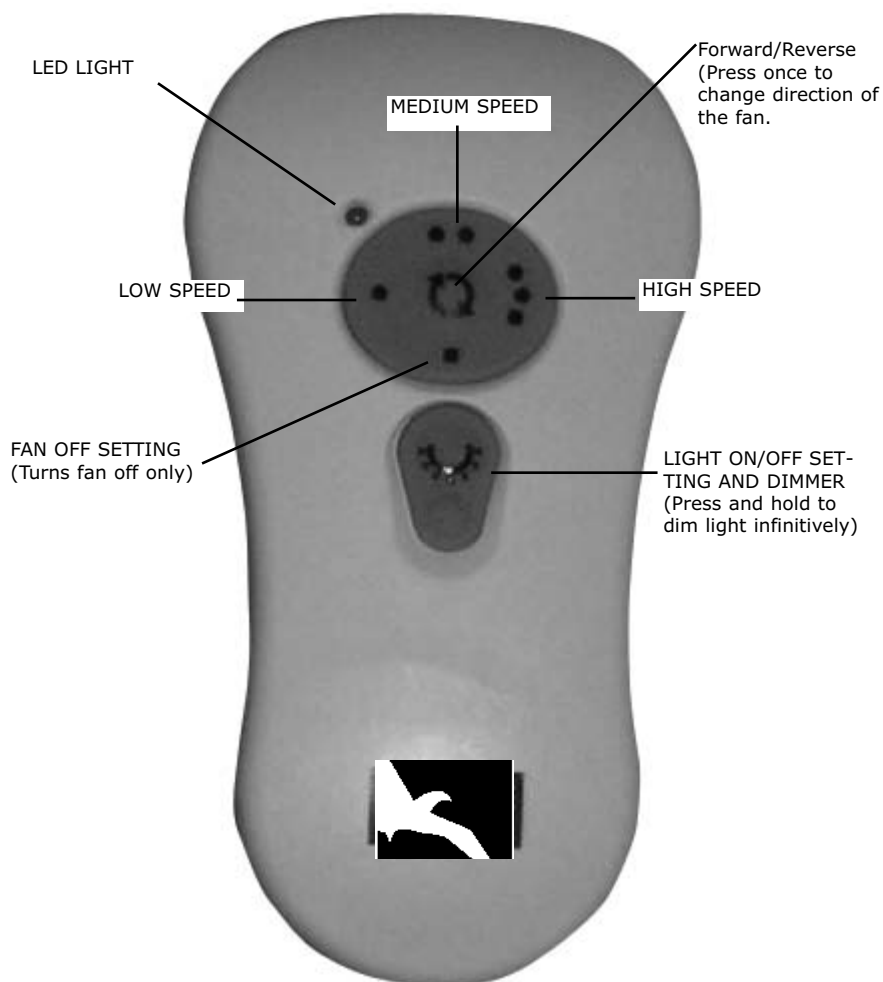

FAN SPEED Depress "1 dot" for low speed, "2 dots" for medium or "3 dots" for high. To turn fan off press square".

LIGHT DIMMER To turn light on, press light dimmer once quickly. To turn off press once quickly while light is on. To dim light hold down button "light dimmer". The light will cycle from bright to dim to bright until button is released. Light will maintain last setting if turned off.

FORWARD/REVERSE Depress rev button allow a few seconds for remote to change rotation direction.

**For Customer Service Call
866-449-2821**