

INSTALLATION AND SAFETY INSTRUCTIONS

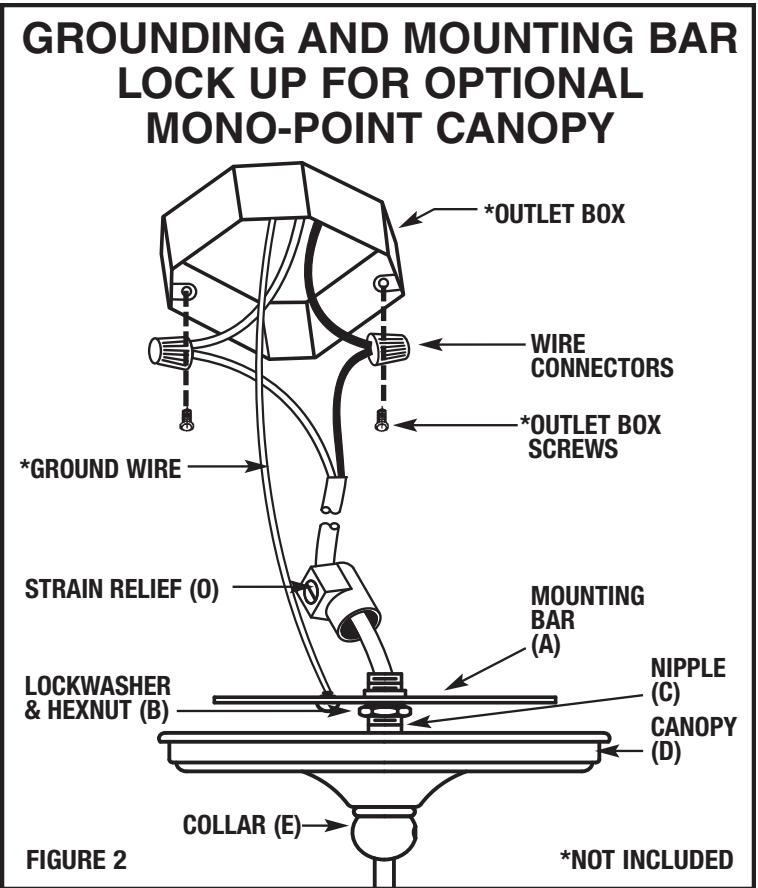
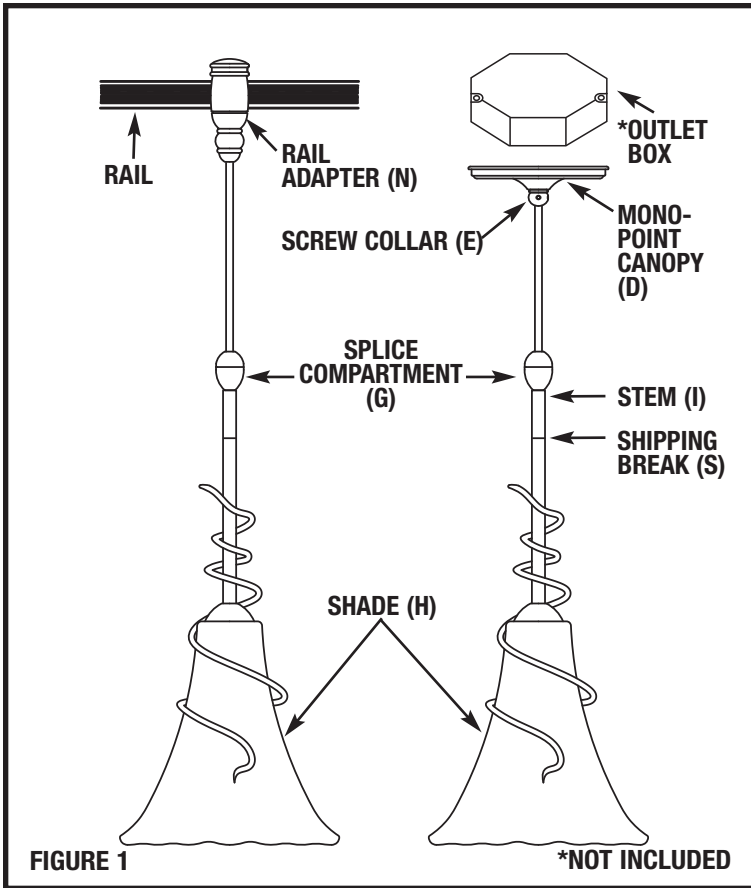

IMPORTANT SAFETY INSTRUCTIONS

- Be sure the electricity to the system you are working on is turned off; either the fuse removed or the circuit breaker set at off.
- For use with the 120V Transitions track series by Sea Gull Lighting.
- Caution – To reduce the risk of burn during relamping remove from the track before relamping.
- Use of other manufacturers components will void warranty, listing, and create a potential safety hazard.
- If you are unclear as to how to proceed, contact a qualified electrician.
- Minimum distance from the front of the lamp to combustible surfaces is 8".
- Make sure all connections are tight.
- Dimming halogen lamps greatly reduces lamp life.
- Lamp gets HOT quickly! Contact switch only when turning on.
- Do not touch hot lens, guard, or enclosure.
- Do not touch the lamp at any time. Use a soft cloth. Oil from skin may damage lamp.
- Do not operate the luminaire fitting with a missing or damaged shield.
- Save these instructions.

NOTE: This pendant can be hung either from a Transitions Series rail (not supplied) or from the supplied canopy. Follow the instructions for the appropriate mounting method.



AMBIANCE[®]
LIGHTING SYSTEMS

LR-105

062408

www.SeaGullLighting.com

1. Determine length of pendant and shorten cable above the splice compartment (G). Be sure to add 5" for electrical connections when installing as a mono-point. Unthread top of splice compartment (G). Set top half of splice compartment (G) and strain relief collar at desired location. **NOTE** Strain relief collar is threaded and should be threaded up and down cable. Be sure 1/4" of cable jacket is protruding out of strain relief collar. Secure in place by tightening the set screws.
2. Assemble stem (I) together at shipping break (S) by holding top half of stem (I) in place and threading socket half of the stem (I).
3. To install shade (H), remove three prongs off of spider (V) by unthreading. Install shade (H) and replace the three prongs onto spider (V) so shade (H) rests evenly on the spider (V).
4. Make connections between socket leads and pendant cable using wirenuts inside the splice compartment (G) – Black to Black/White to White/Ground to Ground. Make sure no wires are left exposed and carefully tuck wires into bottom half of splice compartment (G).
5. Close splice compartment (G) by threading the two halves together.
6. Install lamp (K). Thread glass enclosure (J) over lamp (K).

1. Remove rail adapter (N) by cutting wire below rail adapter (N).
2. Slide collar (E), canopy (D), mounting bar (A), lockwasher & hex nut (B), and nipple (C) to the top of the splice compartment (G).
3. Install strain relief (O). Tighten strain relief set screw with a flat head screwdriver.
4. Attach mounting bar (A) to outlet box using outlet box screws (not supplied).
5. Make electrical connections,
 - a. House Black to Fixture Black
 - b. House White to Fixture White
 - c. House Ground to Green Ground Screw
 Make sure no wires are left exposed and carefully tuck wires into outlet box.
6. Raise canopy (D) to ceiling and secure in place by threading collar (E) to nipple (C).

ATTACH PENDANT TO RAIL (Fig.3)

1. Unthread cap (R) from rail adapter (N).
2. Making sure contacts (Q) will align with conductors (P) on rail, set the bottom of rail adapter (N) to the bottom of the rail and "roll" rail adapter (N) up onto the rail.
3. Install fixture to rail by closing hinged side of rail adapter (N) over rail and threading cap (R) back onto adapter (N) tightly.

FIXTURE INSTALLATION

CORRECT

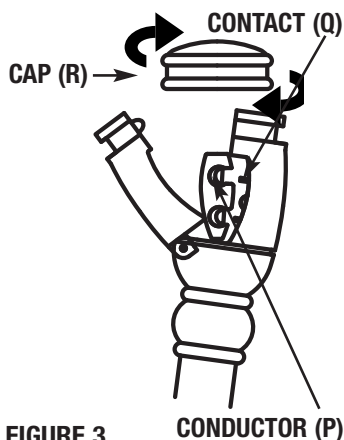

FIGURE 3

INCORRECT

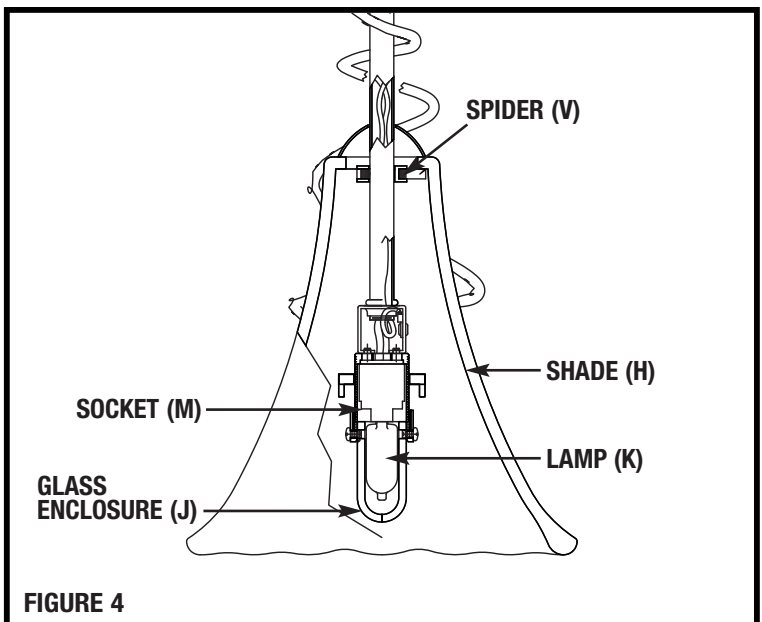
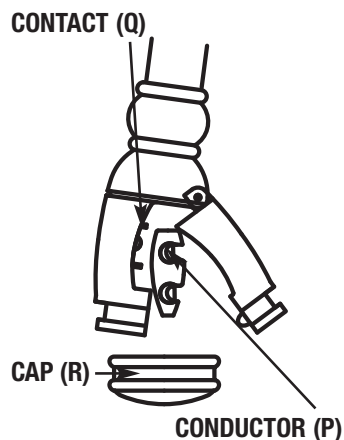

FIGURE 4