

STYLE NO. OC1888/ JCP LOT #781-9664

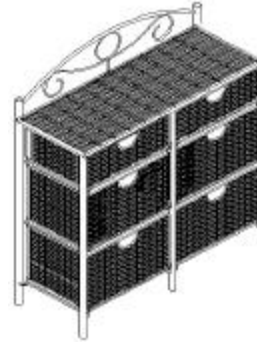





SOUTHERN ENTERPRISES INC.

NOTE.... This product has been engineered for easy assembly and constructed for durability
Please take time to read and follow assembly instructions.



6-DRAWER WICKER STORAGE UNIT

HARDWARE LIST

| | | | |
|--|---|--|--|
| 1  Short Bolt 6 Pcs | 2  Long Bolt 2 Pcs | 3  Phillip Bolt 24Pcs | 4  Allen Wrench 1 Pc |
|--|---|--|--|

Please count, identify and compare parts and hardware list to be sure all parts are present.
It may help to divide parts and label them to correspond with part list. Extra hardware may be included.
If any items are missing, please contact our parts/service department at
(800) 633-5096 or in Dallas (972) 869-0111/ 9am – 4pm Mon-Fri Central time.
Missing or damaged hardware and/ or parts will be replaced free of charge.
WE DO NOT SELL PARTS. WE DO NOT RECOMMEND MODIFYING PRODUCT (S) AND WE ARE NOT RESPONSIBLE FOR ANY DAMAGES DUE TO PRODUCT MODIFICATION (S).
If this product has not been purchased from our retail affiliates (within 9 months), we are under no obligation to provide parts or replacement merchandise.

Parts will not be available for items arriving fully assembled.

Style No. OC1888
JCP LOT #781-9664

PARTS REPLACEMENT FORM

Customer Name _____

| | | |
|-----------------|----------------------|--------------------|
| PARTS LETTER | PARTS DESCRIPTION | QUANTITY NEEDED |
|-----------------|----------------------|--------------------|

Street, City, State, Zip _____



SOUTHERN ENTERPRISES INC.
P.O. Box 59996 Dallas, Texas 75229

Please indicate where you purchased this item.
Store/ website/ catalog _____

Please indicate color/ size/ style number.
_____/_____/_____

PARTS LIST

A. Back Panel 1PC

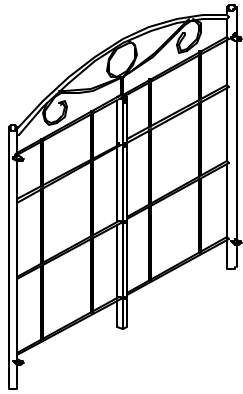

B. Left Side Panel 1PC

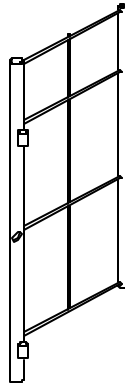

C. Right Side Panel 1PC

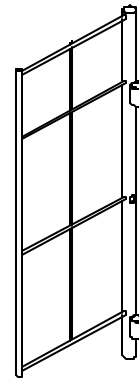

D. Middle Divider Panel 1Pc

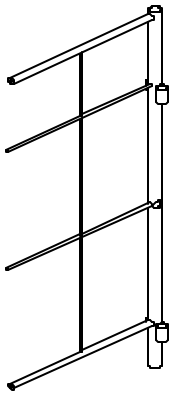

E. VERTICAL-TIP-END Shelf-Frame 4 Pcs

REAR-END CURVED HANGER

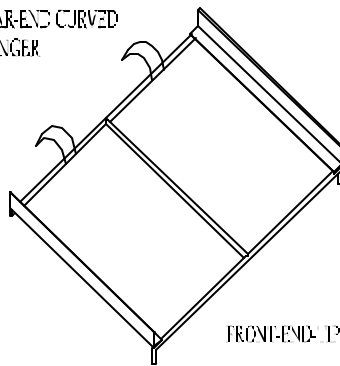

F. HORIZONTAL-TIP-END Shelf-Frame 2Pcs

REAR-END CURVED HANGER

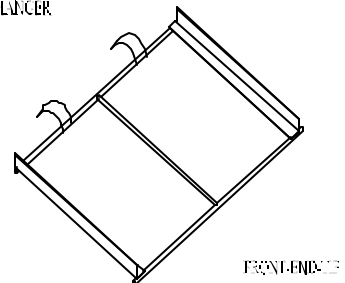

G. Large Wicker Basket 4PCS

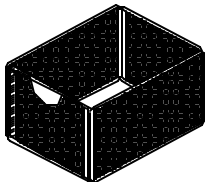

H. Small Wicker Basket 2PCS

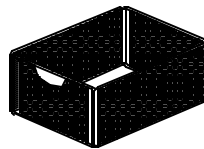

J. Basket Bottom Panel 6PCS

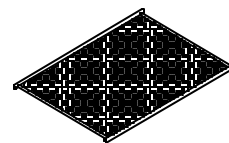

K. Wicker Top Panel 1 PC

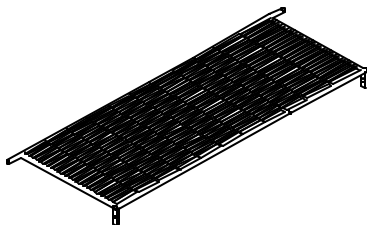

ASSEMBLY INSTRUCTIONS

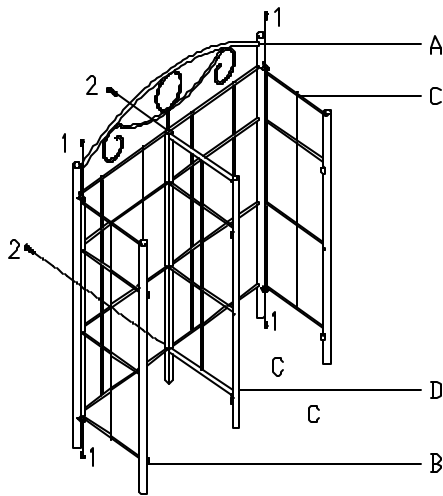

FIG#1

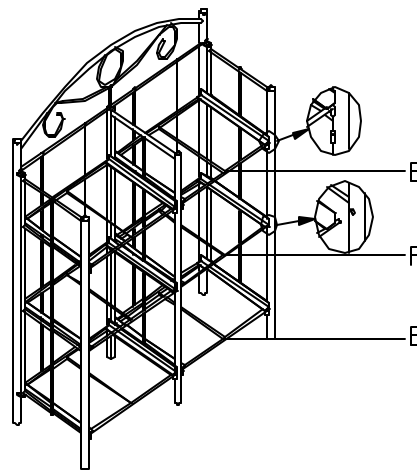

FIG# 2

STEP 1

Insert Short Bolts (1) through connecting-piece on the Back Panel (A) to attach Left Side Panel(B) & Right Side Panel (C) to Back Panel (A). Slightly tighten with Allen Wrench (4).

Insert Long Bolts (2) through holes on the middle-bar of Back Panel (A) to attach Middle Divider Panel(D) to Back Panel (A). Slightly tighten with Allen Wrench (4). **SEE FIG# 1**

STEP 2

Identify both Shelf-Frames of parts#(E)(F) first, then attach HORIZONTAL-END-TIP Shelf-Frame (F) to position by hanging its hook on the bar of Bottom Back Panel (B), meanwhile with its FRONT-END-TIP goes horizontally into the holes on inner side of both Side Panels (B)(C), and Middle Divider Panel (D). **SEE FIG# 2**

Attach VERTICAL -END-TIP Shelf-Frame (E) to position by hanging its hook on bars of Bottom Back Panel (B) meanwhile place FRONT-END-TIP vertically into the small RINGS on inner side of both Side Panels (B) (C), and Middle Divider Panel (D). **SEE FIG# 2**

FIG#3

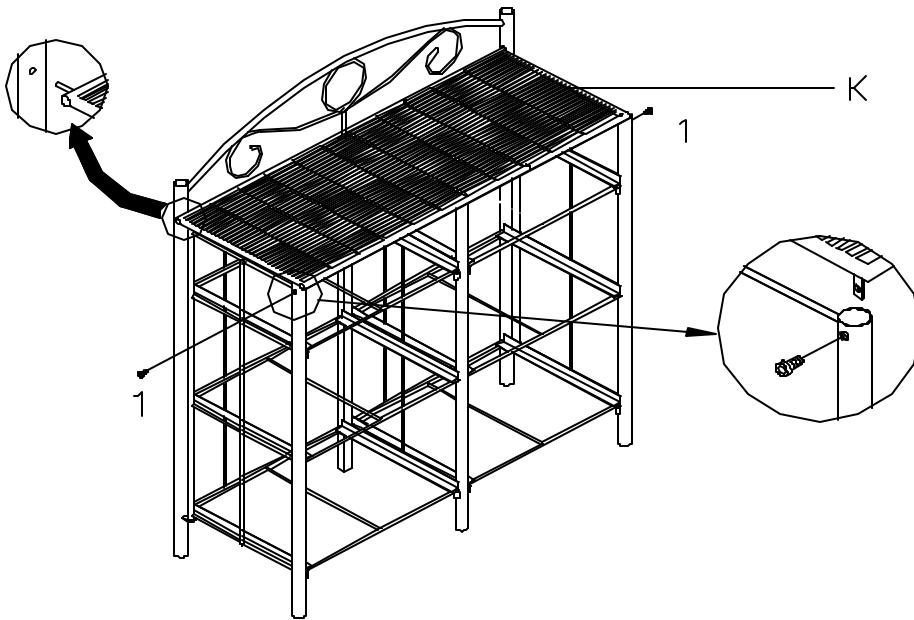

STEP 3

Insert the sticker on rear end of Wicker Top Panel (K) into holes on the posts of Back Panel (A), then push the connector-piece on the front end of Wicker Top Panel (K) into posts of Left Side Panel (B) & Right Side Panel (C) & Middle Panel (D). Please insert Short Bolts (1) through holes on post of both Side Panels (B) (C). Tighten with Allen Wrench (4) . **SEE FIG# 3**

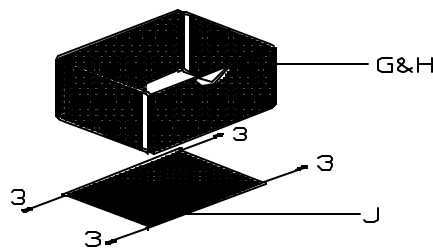

FIG# 4

STEP 4 Please put Basket Bottom Panel (J) into Wicker Basket (G) (H), please insert Phillip Bolt (3) through hole on Wicker Baskets (G) (H) to secure and tighten the unit. SEE FIG# 4 Place the completed baskets onto **Shelf-Frames (E) (F)**.

YOUR BEAUTIFUL 6-DRAWER WICKER STORAGE UNIT IS FINISHED AND READY TO USE .



SOUTHERN ENTERPRISES, INC

P.O. Box 59996 Dallas, Texas 75229

THIS PRODUCT IS NOT INTENDED FOR COMMERCIAL USE.