



**SOUTHERN ENTERPRISES INC.**





NOTE.... This product has been engineered for Easy assembly and constructed for durability  
 Now please take time to read through and follow assembly instructions.



**IRON/WICKER STORAGE BAKERS RACK**

STYLE NO. BE1886

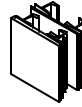



**HARDWARE LIST**

<p>1</p>  <p>1/4*1-1/4" L Medium Bolt 22 PCS</p>	<p>2</p>  <p>1/4**1/2" L Short Bolt 2 PCS</p>	<p>3</p>  <p>1/4**2-1/4" L Long Bolt 4PCS</p>	<p>4</p>  <p>Cap 4 PCS</p>	<p>5</p>  <p>Phillip Bolt 16PCS</p>	<p>6</p>  <p>Wrench 1 PC</p>
---	--	--	---	--	---

Please count, identify and compare parts and hardware list to be sure all parts are present. It may help to divide parts and label them to correspond with part list. Extra hardware may be included. If any items are missing, please contact our parts/service department at (800) 633-5096 or in Dallas (972) 869-0111/ 9am – 4pm Mon-Fri Central time. Missing or damaged hardware and/ or parts will be replaced free of charge. **WE DO NOT SELL PARTS. WE DO NOT RECOMMEND MODIFYING PRODUCT (S) AND WE ARE NOT RESPONSIBLE FOR ANY DAMAGES DUE TO PRODUCT MODIFICATION (S).** If this product has not been purchased from our retail affiliates (within 9 months), we are under no obligation to provide parts or replacement merchandise. We will ship parts if available, this is not a warranty.

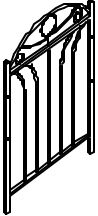
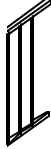
<p><b>Parts will not be available for items arriving fully assembled.</b></p> <p><b>PARTS REPLACEMENT FORM</b></p> <p>Style No. BE 1886</p>			
Customer Name	PARTS LETTER	PARTS DESCRIPTION	QUANTITY NEEDED
_____	_____	_____	_____
Street, City, State, Zip			
_____			
_____			
	<p>Please indicate where you purchased this item.          Store/ website/ catalog</p> <p>_____</p>		
<p>SOUTHERN ENTERPRISES INC.          P.O. Box 59996 Dallas, Texas 75229</p>	<p>Please indicate color/ size/ style number.          _____/_____/_____</p>		

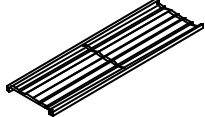
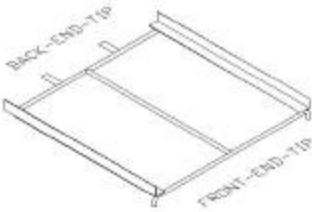
**PARTS LIST**

<p><b>A. Upper Back Panel 1PC</b></p> 	<p><b>B. Bottom Back Panel 1PC</b></p> 	<p><b>C. Left Side Panel 1PC</b></p>
<p><b>D. Right Side Panel 1PC</b></p>	<p><b>E. Metal Cross Bar 2PCS</b></p>	<p><b>F. Divider Tube 1PC</b></p> 
<p><b>G. Wood Top Panel 1PC</b></p>	<p><b>H. Top Side Panel 2PCS</b></p>	<p><b>I. Wire Shelf 2PCS</b></p> 
<p><b>J. TIP-END-Shelf-Frame 2PCS</b></p> 	<p><b>K. Shelf-Frame 2PCS</b></p> 	<p><b>L. Wicker Basket 4PCS</b>  <b>M. Basket Bottom Panel 4PCS</b></p>

# ASSEMBLY INSTRUCTION

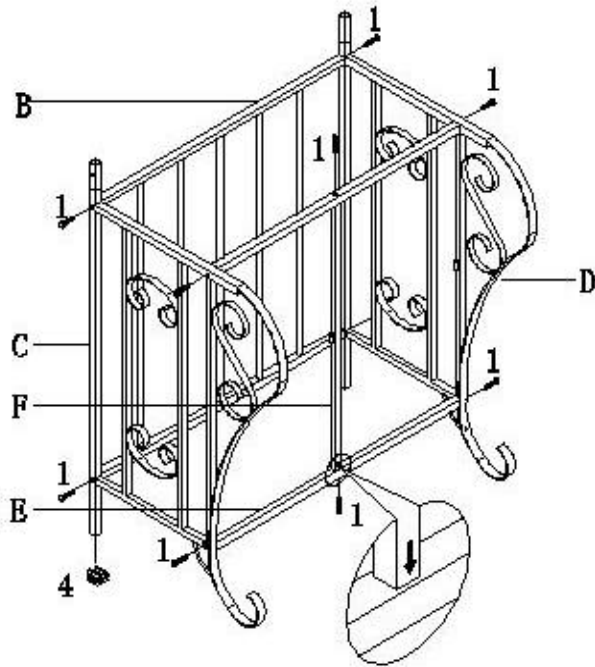

FIG# 1

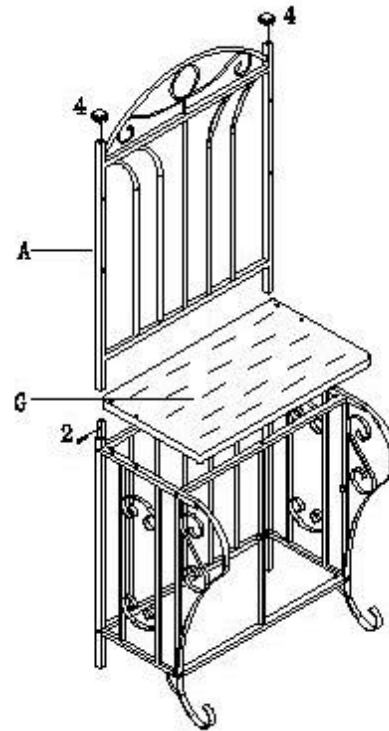

FIG# 2

## STEP 1

Please insert Cap (4) to bottom of rear leg of both Side Panels (C)&(D) and top end of Upper Back Panel(A).

### SEE FIG# 1 and FIG# 2

Please insert Medium Bolts (1) through holes on Left Side Panel (C) to attach Bottom Back Panel (B) and both Metal Cross Bars (E), semi-tighten by Wrench (6). **The small RING on inner side of both side panels should be facing inside.**

Please insert Medium Bolts (1) through holes on both Metal Cross Bars (E) to attach Divider Tube (F) **with the arrow pointing down** in between, please semi-tighten by Wrench (6). SEE FIG# 1

And then Please insert Medium Bolts (1) through holes on Right Side Panel (D) to attach to Bottom Back Panel (B) and both Metal Cross Bars (E), please semi-tighten by Wrench (6). **SEE FIG# 1**

## STEP 2

Please attach Upper Back Panel (A) onto Bottom Back Panel (B) and then please secure both parts by Short Bolts (2), please semi-tighten by Wrench (6).

Attach Wood Top Panel (G) onto the Left Side Panel (C)& Right Side Panel (D) .

### SEE FIG# 2

**STEP 3**

Please insert Long Bolt (3) through holes on both Side Panels (C)&(D) & Wood Top Panel (G) to secure both Top Side Panels (H) in position, please semi-tighten by Wrench (6). **SEE FIG# 3**

Please insert Medium Bolt (1) through holes on back-side of Upper Back Panel (A) to secure both Wire Shelves (I), please semi-tighten by Wrench (6).and then,

Please insert Medium Bolt (1) through holes on side of both Top Side Panels (H) to secure both Wire Shelves (I), please semi-tighten by Wrench (6).

**now, Please identify both Shelf-Frames of parts#(J)(K) first,** and then attach **TIP-END-Shelf-Frame (J)** to position by hanging its hook to bottom-bar of Bottom Back Panel(B) meanwhile with its TIP-END goes into the **small RINGS on inner side of both Side Panels (C)(D), and Divider Tube (F).** **SEE FIG# 3.**

FIG# 3

Please attach **Shelf-Frame (K)** to position by hanging its hook to bottom -bar of Bottom Back Panel (B) As shown on **FIG#3.**

**NOW PLEASE ADJUST ALL PARTS AND TIGHTEN ALL BOLTS FROM ABOVE STEPS BY WRENCH (6).**

FIG# 4

**STEP 4**

Please put Wicker Basket Bottoms (M) into Wicker Baskets (L) ,secure and tighten them with Phillip Bolt (5) **SEE FIG# 4**  
Then put the complete baskets onto **Shelf-Frames (J) (K).**



SOUTHERN ENTERPRISES, INC

**P.O. Box 59996 Dallas, Texas 75229**

YOUR BEAUTIFUL IRON/WICKER STORAGE BAKERS RACK IS FINISHED AND READY TO USE .

**THIS PRODUCT IS NOT INTENDED FOR COMMERCIAL USE.**