



MODEL N° 90029

OWNER'S MANUAL

COPY

Keep this Identification Number in case you must contact our Customer Service Department.

REGISTER YOUR LIFETIME PRODUCT TODAY!

There are benefits to registering your Lifetime product. With our new online product registration form, it's fast and easy! Register with us at www.lifetime.com and enjoy these great benefits:

- Receive exclusive money-saving offers from BuyLifetime.com, our online store, as well as NEW product notifications and special closeout promotions!
- In the unlikely event of a product recall or safety modification, we will notify you.
- Registering your product guarantees you warranty service. If you do not register your product, your warranty rights will not be diminished. But you will need to provide a sales receipt to verify your product purchase date before warranty service will be provided.

LIFETIME'S PROMISE TO YOU:

Maintaining your privacy is our long-standing policy at Lifetime. And you can rest assured that Lifetime will not sell or provide your personal data to other third parties, or allow them to use your personal data for their own purposes.

We invite you to read our privacy policy at www.lifetime.com

REGISTER today!

Save this instruction in the event that the manufacturer has to be contacted for replacement parts.

****U.S. and Canada customers ONLY****

IF ASSISTANCE IS NEEDED,

DO NOT CONTACT THE STORE!

CALL OUR CUSTOMER SERVICE DEPARTMENT at 1 (800) 225-3865

HOURS: 7:00 a.m. to 5:00 p.m. Monday through Friday (Mountain Standard Time)

Call, or visit our Web site for Saturday hours

For customers outside the U.S. or Canada, please contact the store for assistance.



SAFETY INSTRUCTIONS



FAILURE TO FOLLOW THESE WARNINGS MAY RESULT IN SERIOUS INJURY OR PROPERTY DAMAGE AND WILL VOID WARRANTY.

To ensure safety, do not attempt to assemble this system without following the instructions carefully. Check entire box and inside all packing material for parts and/or additional instruction material. Before beginning assembly, read the instructions and identify parts using the hardware identifier and parts list in this document. Proper and complete assembly, use and supervision are essential for proper orientation and to reduce the risk of accident or injury. A high probability of serious injury exists if this system is not installed, maintained, and/or operated properly.

- If using a ladder during assembly, use extreme caution.
- Two capable adults are recommended for this operation.
- Check base daily for leakage. Leaks may cause system to fall.
- Assemble the pole sections properly. Failure to do so could cause the pole sections to separate during play or transport.

Most injuries are caused by misuse and/or not following instructions. Use caution when using this system.



WARNING

To ensure your safety, do not attempt to assemble this system without reading and following all instructions carefully. Identify and inventory the parts using the Parts List. Failure to comply with any of the warnings in these instructions may result in serious personal injuries such as cuts, broken bones, nerve damage, paralysis, brain injury, or death. Failure to comply may also result in property damage. Please heed all warnings and cautions.

ASSEMBLY GUIDES

Refer to the following areas throughout the instructions to assist in the assembly process:

This area is located at the top, left-hand corner of the page and indicates which tools and hardware are needed to complete the assembly steps on a page.



This area is located at the top, right-hand corner of the page and shows an image of the product with shaded parts indicating which section is being assembled.



This area is usually located in the bottom, left-hand corner of a step and indicates that special attention is needed to perform a particular part of a step.



These areas are usually located in the bottom, right-hand corner of a step and indicate that damage to the product or serious injury may occur if the caution or warning is not heeded.



PARTS & HARDWARE LIST

ID	DESCRIPTION	QTY	✓
ALG	Pole Section	3	<input type="checkbox"/>
AZM	Base	1	<input type="checkbox"/>
AZX	Base Plate	1	<input type="checkbox"/>
AZT	Ball/Rope/Clasp Assembly	1	<input type="checkbox"/>
BQB	Ball Pump and Needle	1	<input type="checkbox"/>
BUG	TETHERBALL HARDWARE BAG [1055356]		
AZU	1/2" x 1.9" Metal Spacer	1	<input type="checkbox"/>
AAS	1/4"-20 x 2 3/4" Hex Bolt	1	<input type="checkbox"/>
AZP	1/4"-20 Nylock Nut	3	<input type="checkbox"/>
AZW	1/4"-20 x 5 1/2" Carriage Bolt	2	<input type="checkbox"/>
AZQ	2" Expanding Pole Cap	1	<input type="checkbox"/>
AZR	2" Pole Cap Wedge	1	<input type="checkbox"/>
BUF	Washer Collar Link	1	<input type="checkbox"/>
ABD	5/16" Flat Washer	1	<input type="checkbox"/>
AYT	5/16"-18 Hex Nut	1	<input type="checkbox"/>
AZV	5/16"-18 x 3 1/2" Phillips Screw	1	<input type="checkbox"/>
AZY	Base Plug	2	<input type="checkbox"/>
AZS	Split Collar	2	<input type="checkbox"/>
BCA	Top Cap	1	<input type="checkbox"/>

STOP!

BEFORE BEGINNING ASSEMBLY

STOP!

- Keep the hardware bags and their contents separate. If any parts are missing, call our Customer Service Department.
- Test fit all Bolts by inserting them into their respective holes. If necessary, carefully scrape away any excess powder coating buildup from inside the holes. Do not scrape away all of the powder coating. Bare metal may rust. You may need to pound some Bolts into place with a hammer or mallet.

TOOLS & MATERIALS REQUIRED

Tools & Materials not included unless otherwise indicated

7/16"



(2)

Phillips
Screwdriver



(1)

Safety Glasses



(1 for each person)

Funnel



(1)

Scrap Wood



(1)

Pressure Gauge

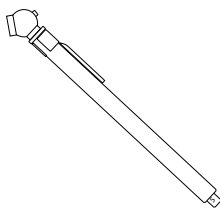

BQB-Ball Pump
& Needle



(1, included)

Water Source

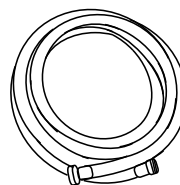

Sand



(145 lbs. (66 kg))

Two adults required to complete assembly

PARTS IDENTIFIER

MISCELLANEOUS PARTS

Parts not shown to scale

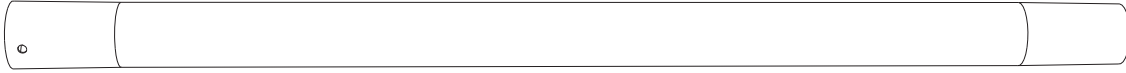

ALG (x3)
Pole Section

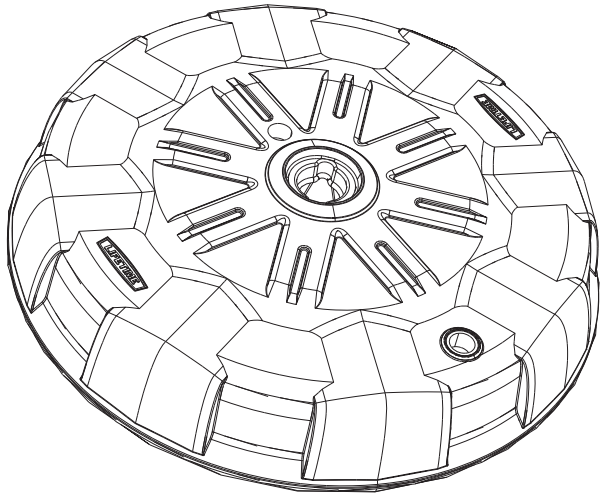

AZM (x1)
Base

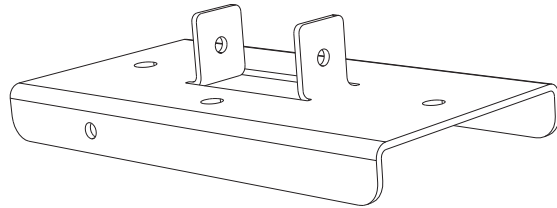

AZX (x1)
Base Plate



AZT (x1)
Ball/Rope/Clasp Assembly

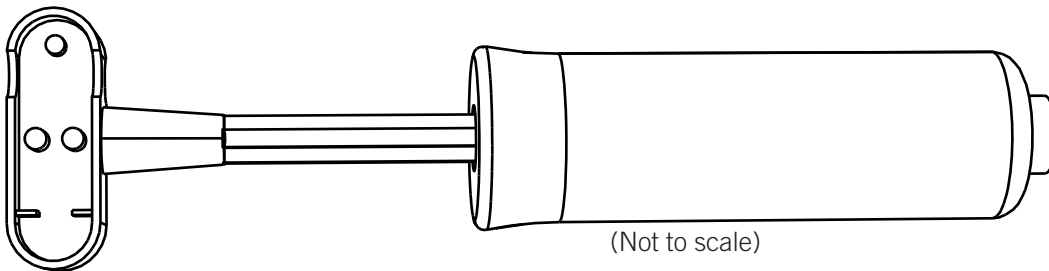

(Not to scale)

BQB (x1)
Ball Pump
(Actual pump may differ from one shown here)

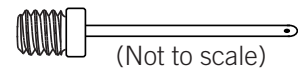

(Not to scale)

BFA (x1)
Ball Needle
(included with BQB-BallPump)

HARDWARE IDENTIFIER

BUG - TETHERBALL HARDWARE BAG [1055356]

Parts shown at actual size

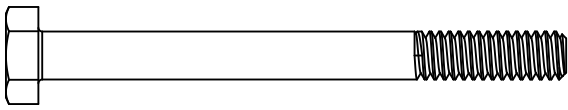

AAS (x1)
1/4"-20 x 2 3/4" Hex Bolt

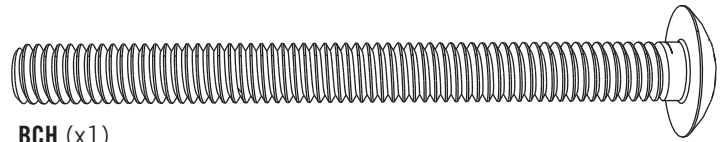

BCH (x1)
5/16"-18 x 3 1/2" Phillips Screw

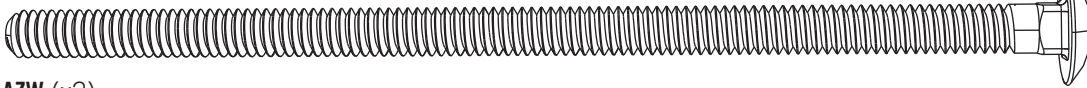

AZW (x2)
1/4"-20 x 5 1/2" Carriage Bolt

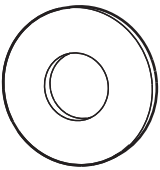

ABD (x1)
5/16" Flat Washer



AZU (x1)
1/2" x 1.9" Metal Spacer

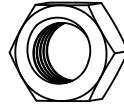

AYT (x1)
5/16"-18 Hex Nut



AZP (x3)
1/4"-20 Nylock Nut

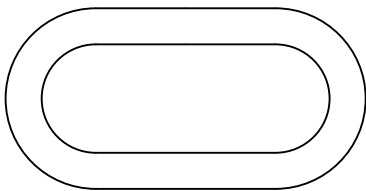

BUF (x1)
Washer Collar Link

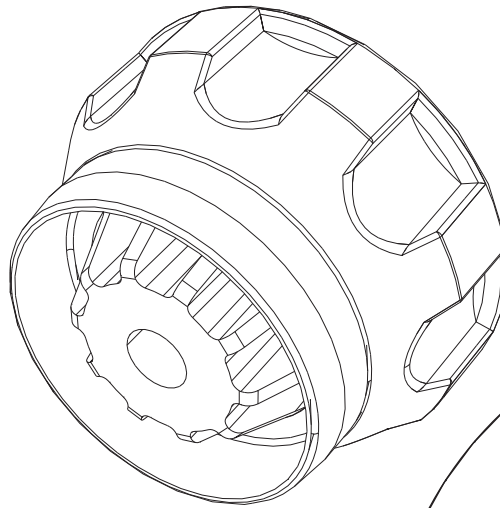

BCA (x1)
Top Cap

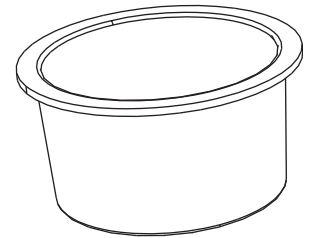

AZY (x2)
Base Plug

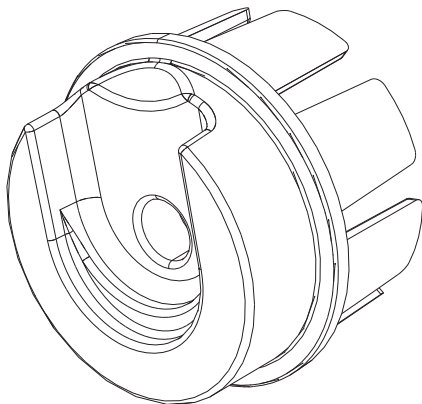

AZQ (x1)
2" Expanding Pole Cap

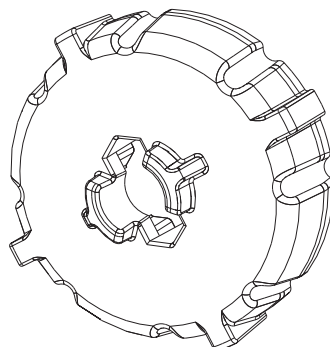

AZR (x1)
2" Pole Cap Wedge



AZS (x2)
Split Collar

SEC 1 POLE ASSEMBLY

HARDWARE REQUIRED

NO HARDWARE REQUIRED FOR THIS SECTION

PARTS REQUIRED

Part not shown to scale



ALG (x3)
Pole Section

TOOLS USED (NOT INCLUDED)



Scrap Wood



TOOLS AND HARDWARE REQUIRED FOR THIS PAGE



NO HARDWARE REQUIRED FOR THIS SECTION

SEC 1

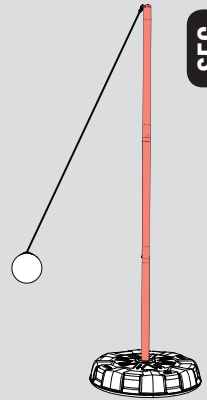

SEC

1.1

POLE ASSEMBLY

Insert the tapered end of a **Pole Section (ALG)** into the flared end of another Pole Section.

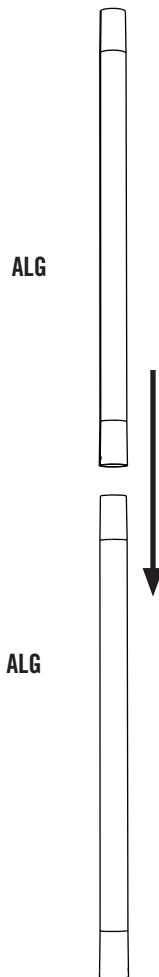

SEC

1.2

Place the flared end of the third Pole Section over the tapered end of the Pole Sections you assembled in Step 1.1.

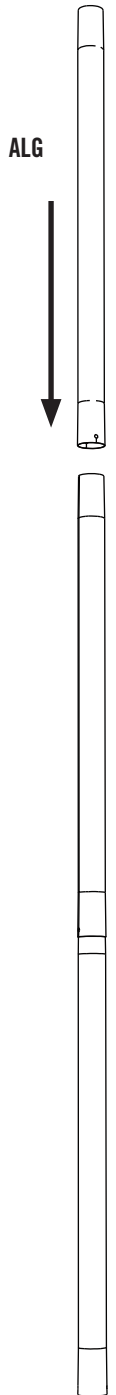

Note: All Pole Sections are the same. The order of assembly makes no difference.



TOOLS AND HARDWARE REQUIRED FOR THIS PAGE



Scrap Wood



NO HARDWARE REQUIRED FOR THIS SECTION

SEC 1

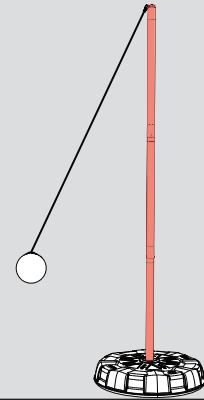

SEC

1.3

ATTENTION: THIS STEP CANNOT BE REVERSED!

In order to seat the Pole Sections, strike each end of the Pole Assembly very hard five to six times on a piece of scrap wood or cardboard.

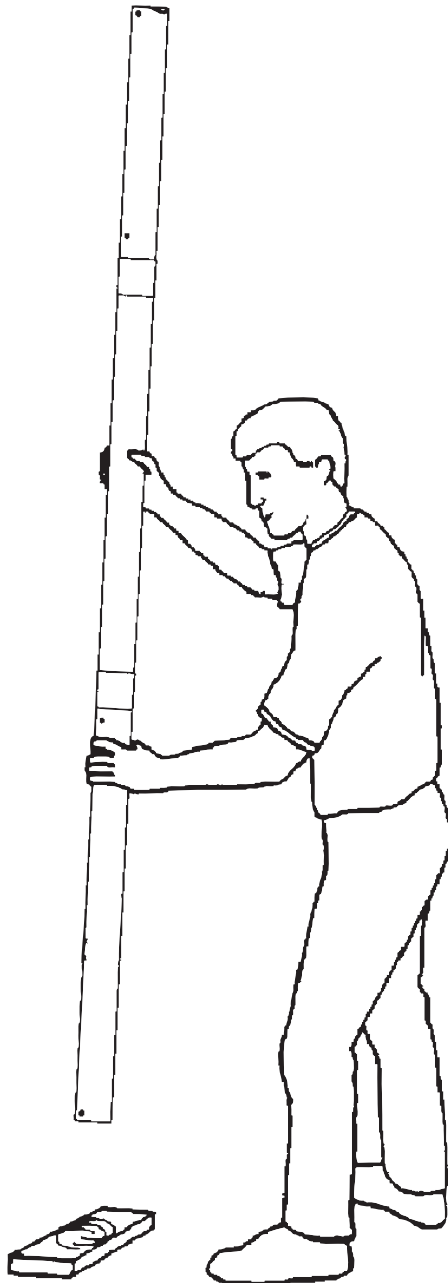

WARNING

Do not hit your feet with the Pole Sections, as serious injury could occur.



WARNING

The Poles must be seated together! Poles must be struck on a hard surface five to six times! Failure to seat the Poles correctly could allow the Poles to separate during use, which could lead to serious personal injuries or property damage.

SEC 2 POLE TO BASE ASSEMBLY

HARDWARE REQUIRED

Parts shown to scale

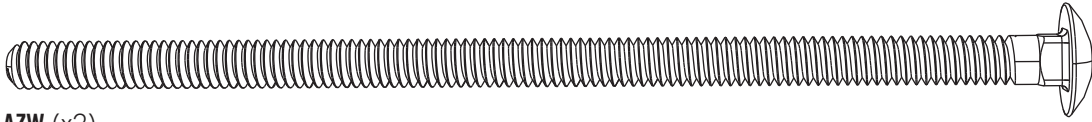

AZW (x2)
1/4"-20 x 5 1/2" Carriage Bolt

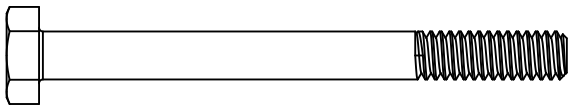

AAS (x1)
1/4"-20 x 2 3/4" Hex Bolt



AZU (x1)
1/2" x 1.9" Metal Spacer



AZP (x3)
1/4"-20 Nylock Nut

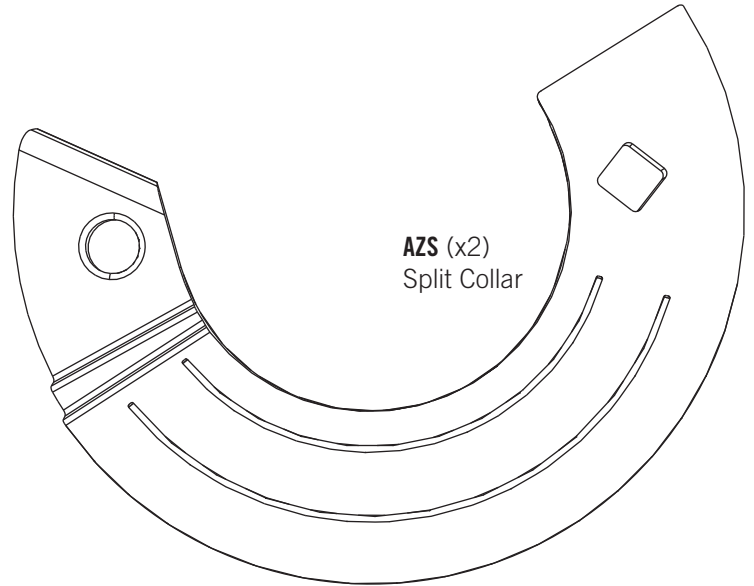

AZS (x2)
Split Collar

PARTS REQUIRED

Parts not shown to scale

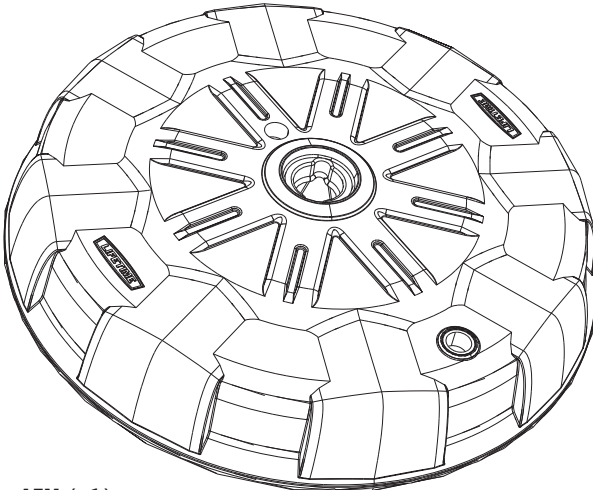

AZM (x1)
Base

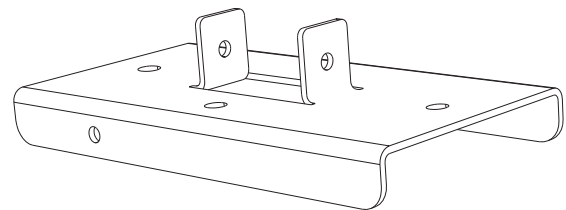

AZX (x1)
Base Plate

TOOLS USED (NOT INCLUDED)



Safety Glasses



7/16" Wrench (x2)



TOOLS AND HARDWARE REQUIRED FOR THIS PAGE



7/16" (x2)



AZU (x1)

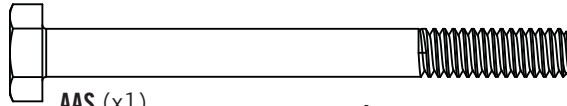

AAS (x1)



AZP (x1)

SEC 2

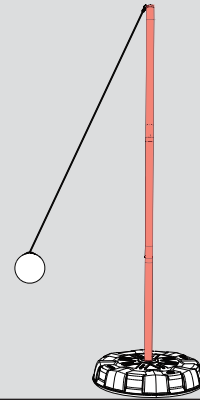

POLE TO BASE ASSEMBLY

SEC

2.1

Turn the **Base (AZM)** on its side and slide the flared end of the **Pole Assembly** through the hole in the Base. Align the tabs of the **Base Plate (AZX)** with the holes on the flared end of the Pole Assembly.

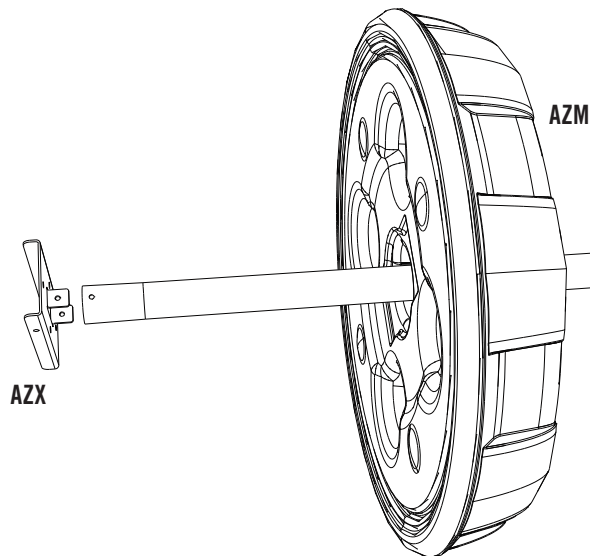

SEC

2.2

With the holes in the tabs of the Base aligned with the holes in the Pole Assembly, secure the Base Plate to the Pole Assembly using the hardware shown. Tighten **Nut (AZP)** securely.

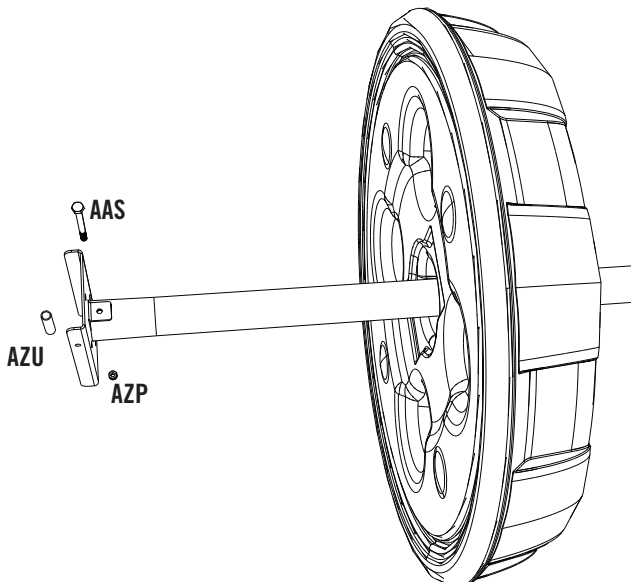

WARNING

Do not place the system in an upright position until instructed. The system may fall over and could result in serious personal injury or property damage.



TOOLS AND HARDWARE REQUIRED FOR THIS PAGE

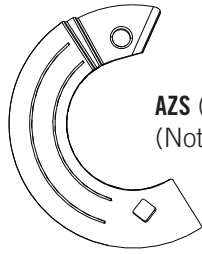

AZS (x2)
(Not to Scale)

SEC 2

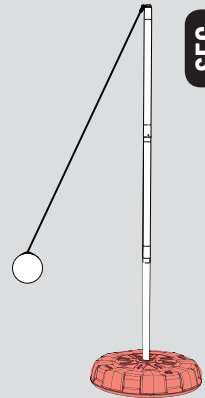

SEC

2.3

Interlock the two halves of the **Split Collar (AZS)** around the Pole Assembly.

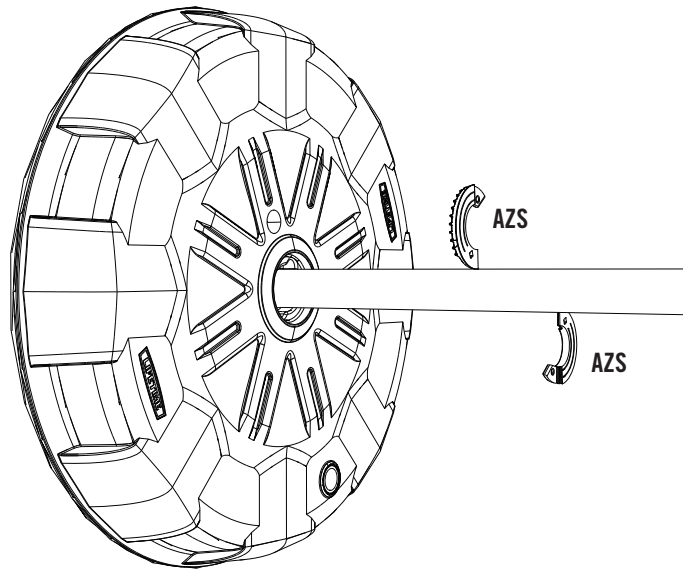

SEC

2.4

Slide Split Collar down to the Base.

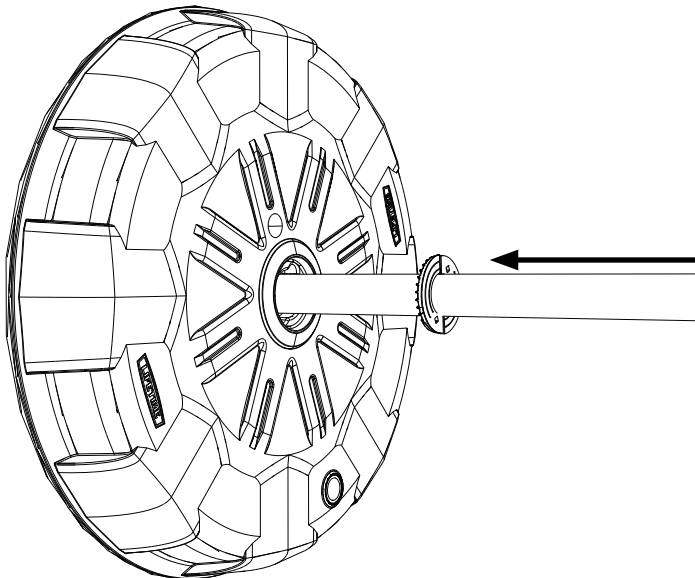

WARNING

Do not place the system in an upright position until instructed. The system may fall over and could result in serious personal injury or property damage.



TOOLS AND HARDWARE REQUIRED FOR THIS PAGE



7/16"

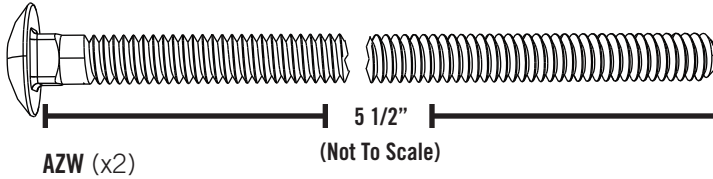

AZP (x2)

SEC 2

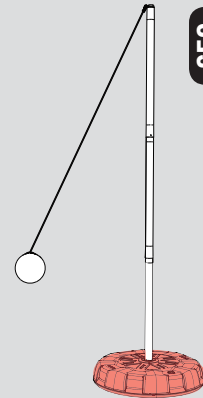

SEC

2.5

Insert the two (2) 1/4"-20 x 5 1/2" Carriage Bolts (AZW) through the holes in the Split Collar and out through the Base Plate.

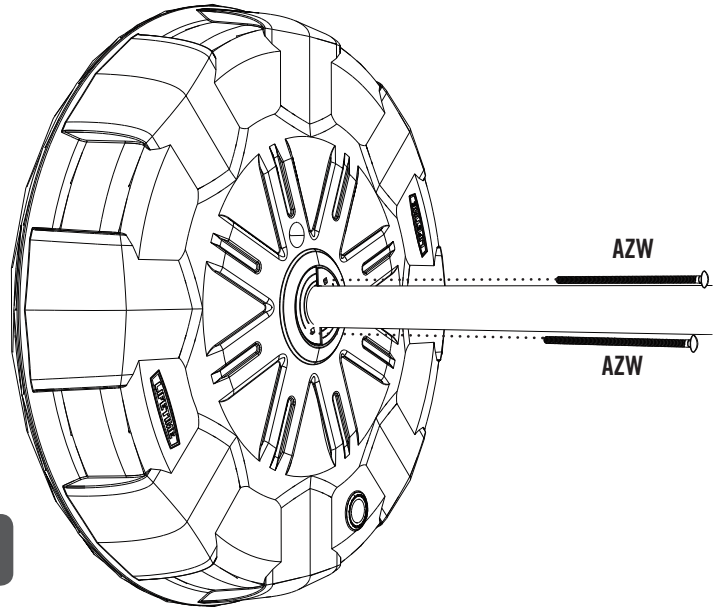

Note: You will need to align the holes in the Split Collar with the holes in the Base Plate.

SEC

2.6

With the holes in the tabs of the Base aligned with the holes in the Pole Assembly, secure the Base Plate to the Pole Assembly with two (2) 1/4"-20 Nylock Nuts (AZP). Tighten Nuts securely, but do not overtighten.

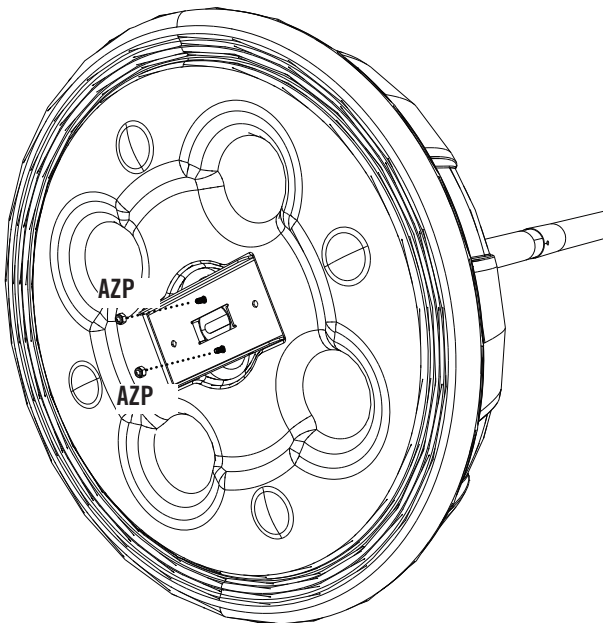

WARNING

Do not place the system in an upright position until instructed. The system may fall over and could result in serious personal injury or property damage.

SEC 3 TETHERBALL TO POLE ASSEMBLY

HARDWARE REQUIRED

Parts shown to scale

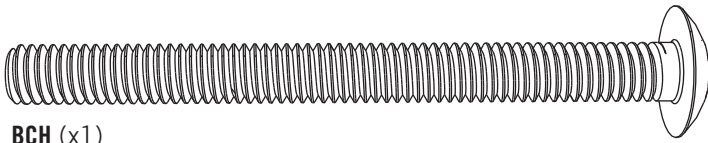

BCH (x1)
5/16"-18 x 3 1/2" Phillips Screw

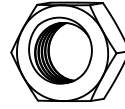

AYT (x1)
5/16" Hex Nut

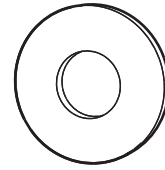

ABD (x1)
5/16" Flat Washer

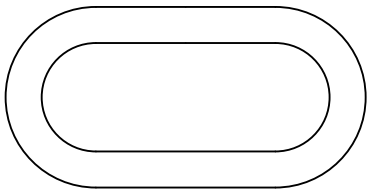

BUF (x1)
Washer Collar Link

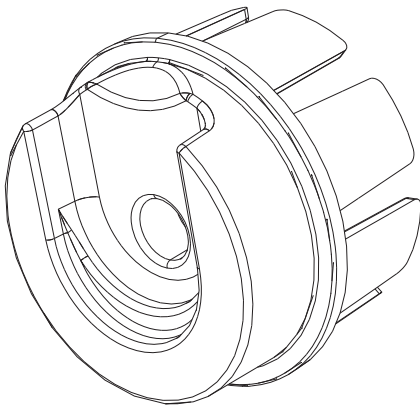

AZQ (x1)
2" Expanding Pole Cap

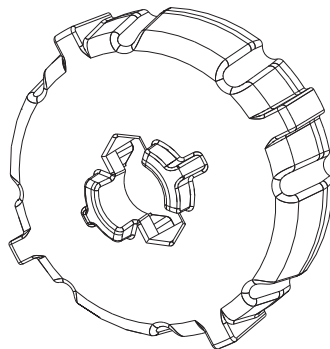

AZR (x1)
2" Pole Cap Wedge

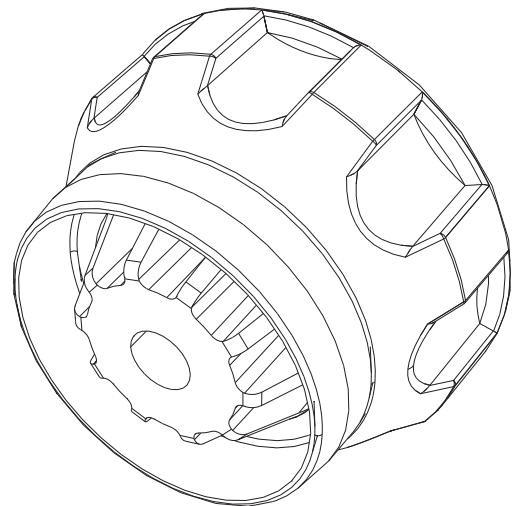

BCA (x1)
Top Cap

PARTS REQUIRED

Part not shown to scale



***AZT** (x1)
Ball/Rope/Clasp Assembly

TOOLS USED (NOT INCLUDED)



Safety Glasses

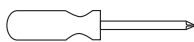

Phillips Screwdriver



TOOLS AND HARDWARE REQUIRED FOR THIS PAGE

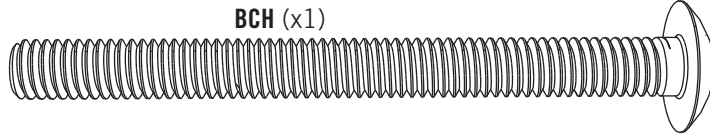

BCH (x1)

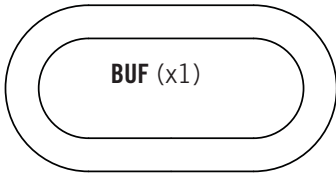

BUF (x1)

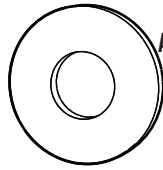

ABD (x1)

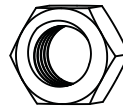

AYT (x1)

SEC 3

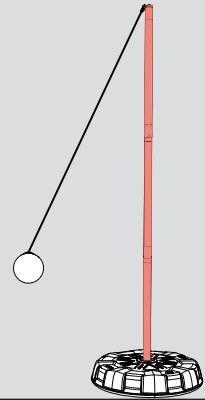

SEC

3.1

TETHERBALL TO POLE ASSEMBLY

Connect the **Washer Collar Link (BUF)**, **Expanding Pole Cap (AZQ)**, and **Pole Cape Wedge (AZR)** together using the **5/16" x 3 1/2" Phillips Screw (BCH)**, **5/16" Flat Washer (ABD)**, and **5/16" Hex Nut (AYT)**. Hand tighten the Nut just enough to secure it inside the Pole Cap Wedge.

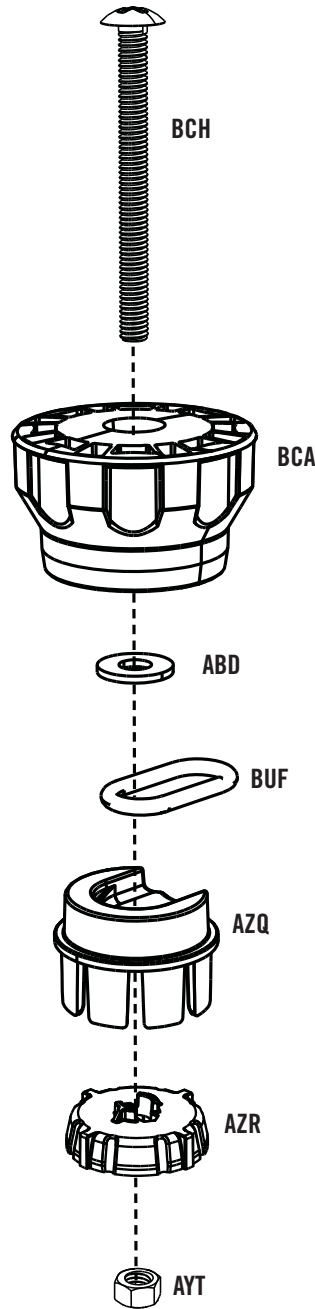



TOOLS AND HARDWARE REQUIRED FOR THIS PAGE

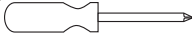

NO HARDWARE REQUIRED FOR THIS SECTION

SEC 3

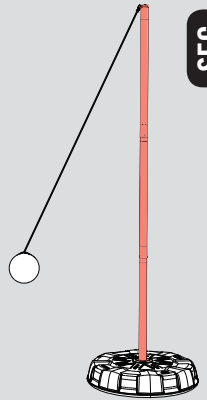

SEC

3.2

Insert the Expanding Pole Cap Assembly into the top of the Pole Assembly.

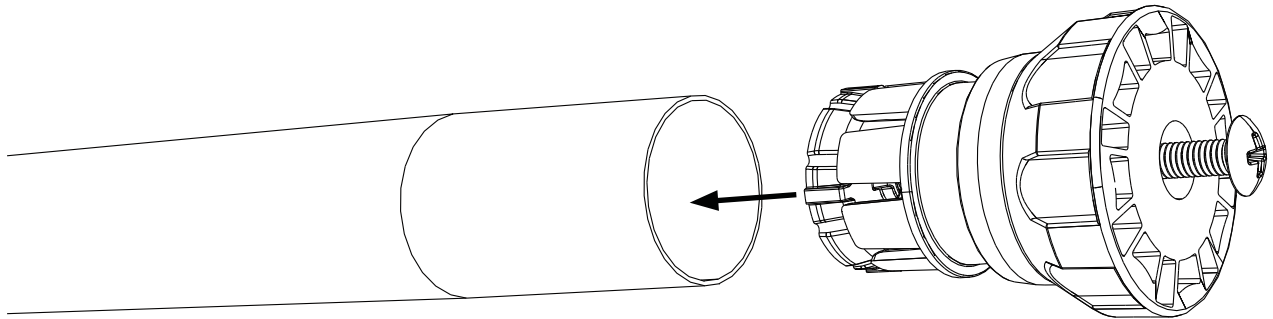

SEC

3.3

Secure the Expanding Pole Cap Assembly to the top of the Pole by tightening the Phillips Head Bolt.

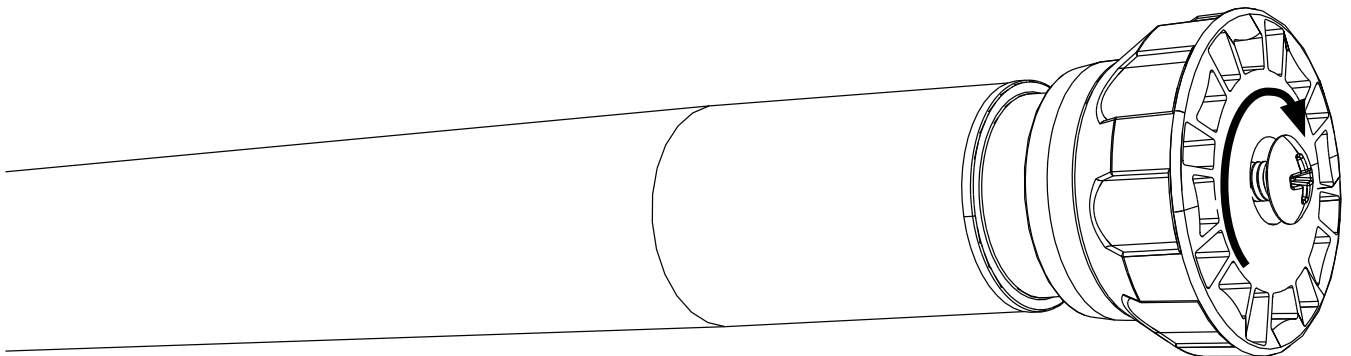

WARNING

Do not place the system in an upright position until instructed. The system may fall over and could result in serious personal injury or property damage.



TOOLS AND HARDWARE REQUIRED FOR THIS PAGE



NO HARDWARE REQUIRED FOR THIS SECTION

SEC 3

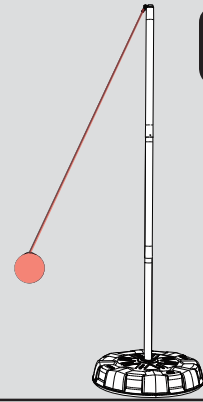

SEC

3.4

Attach the **Ball/Rope/Clasp Assembly (AZT)** to the Washer Collar Link.

AZT

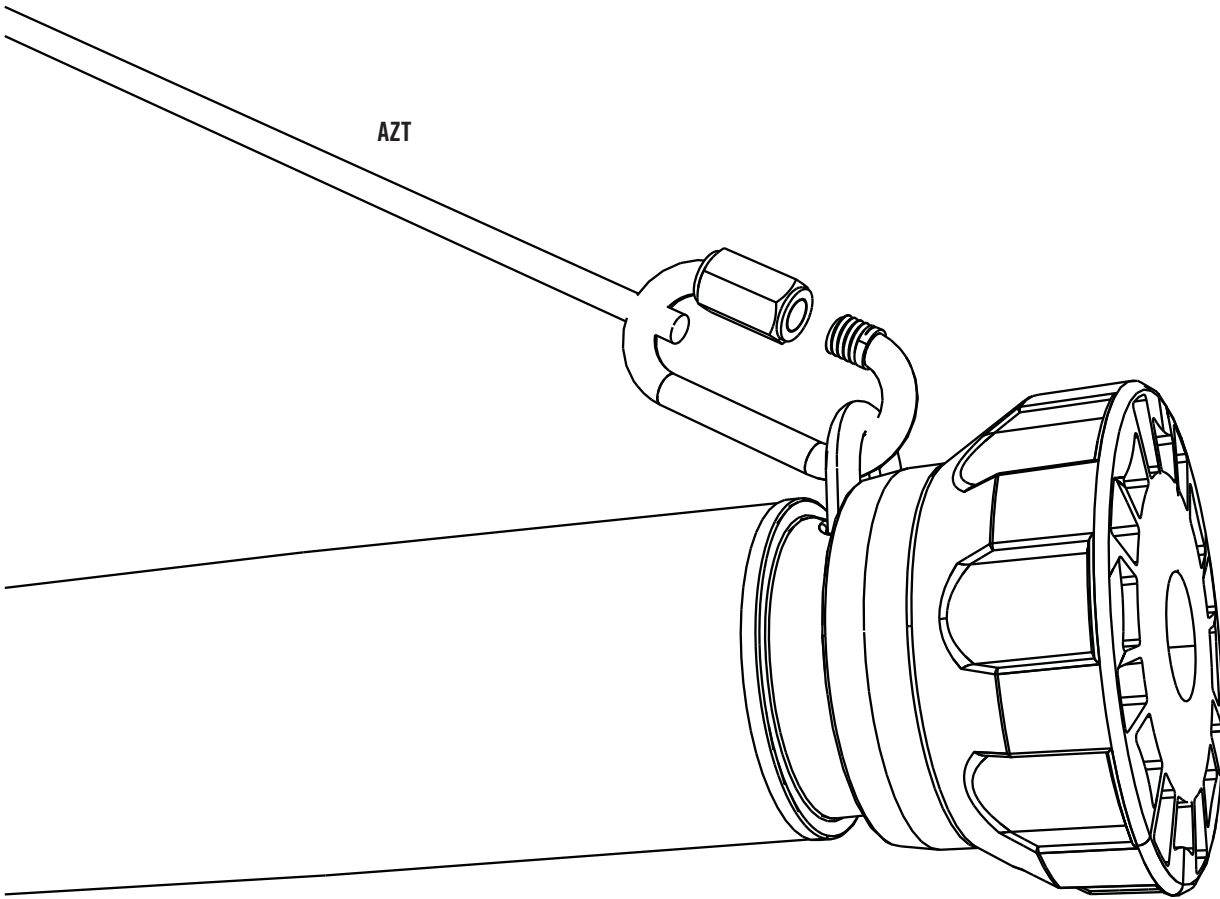

WARNING

Do not place the system in an upright position until instructed. The system may fall over and could result in serious personal injury or property damage.

SEC 4 FILLING THE BASE

HARDWARE REQUIRED

Part shown to scale

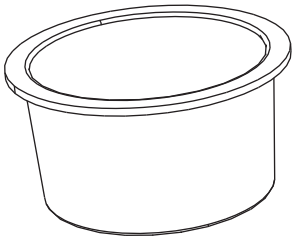

AZY (x2)
Base Plug

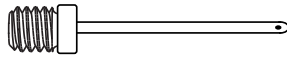

BFA (x1)
Ball Needle

PARTS REQUIRED

NO HARDWARE REQUIRED FOR THIS SECTION

TOOLS USED (NOT INCLUDED)



Safety Glasses



Water Source



(145 lbs (66 kg)) Sand



Funnel

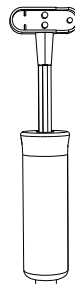

Ball Pump

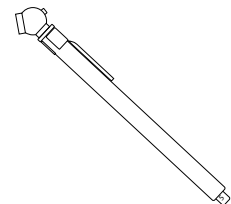

Pressure Gauge



TOOLS AND HARDWARE REQUIRED FOR THIS PAGE

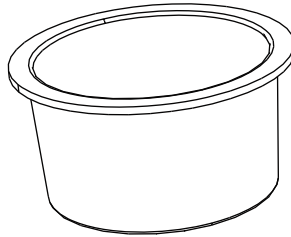
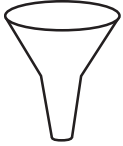

AZY (x2)

SEC 4

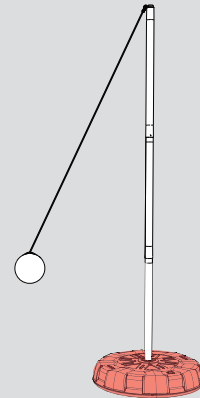

TWO ADULTS ARE REQUIRED TO COMPLETE ASSEMBLY. TO PREVENT SERIOUS INJURIES, THE POLE SHOULD BE HELD BY ONE ADULT AT ALL TIMES WHILE THE BASE IS BEING FILLED.

SEC

4.1

OPTION A: FILLING WITH SAND

(145 lbs (66 kg) of sand required)

- Completely fill the Base with sand. Shake Base frequently to get the sand to settle. You may need to tilt the Base during filling to completely fill Base with sand.
- Insert the **Base Caps (AZY)** into the fill holes.
- Using two adults, carefully stand the system up on a smooth surface.**

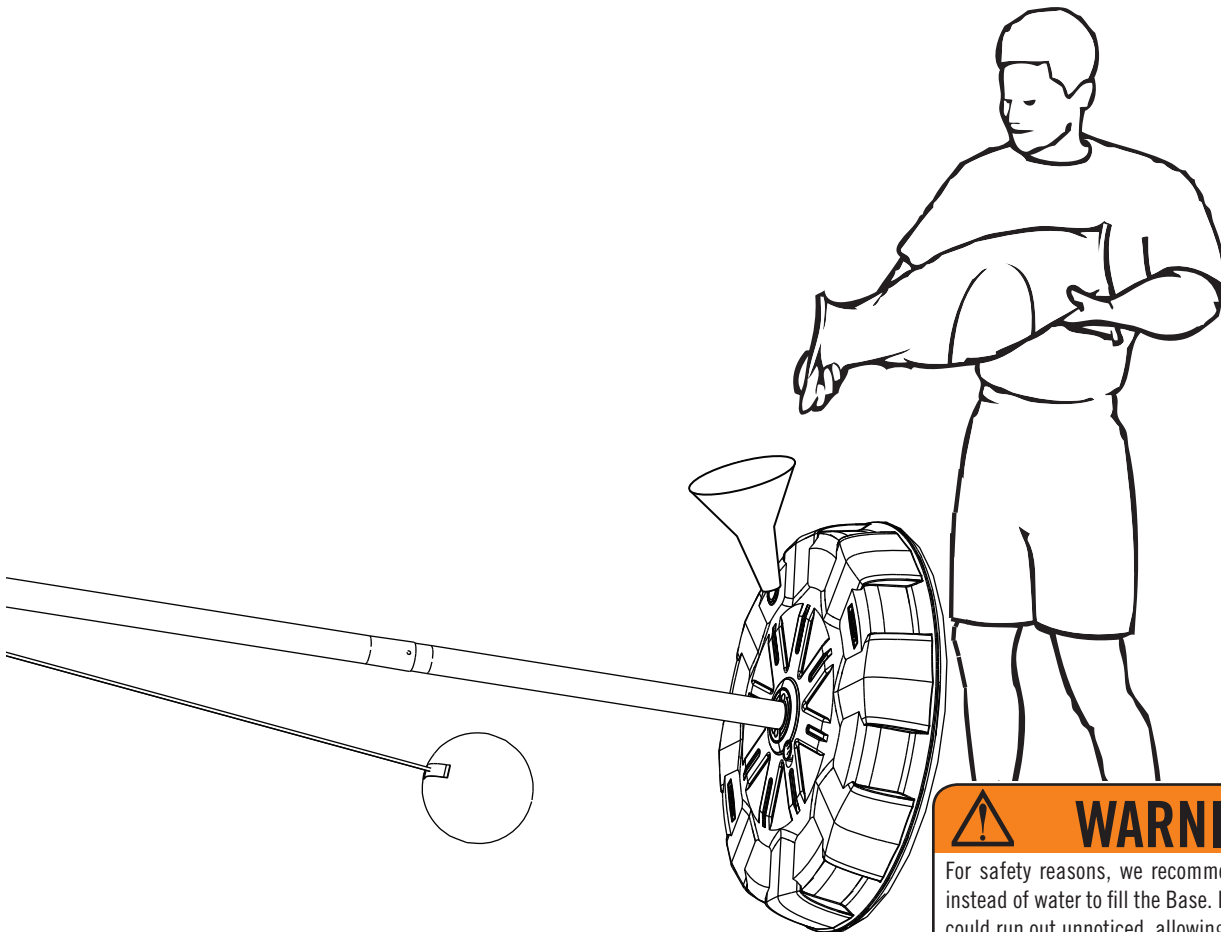

WARNING

For safety reasons, we recommend that sand be used instead of water to fill the Base. If a leak develops, water could run out unnoticed, allowing the system to fall over, resulting in serious personal injuries, or property damage. If using Water, check the Base carefully for leaks. If a leak is found, lay the system down on the ground and call Customer Service. Do not use, stand up, or play on a leaking system.



TOOLS AND HARDWARE REQUIRED FOR THIS PAGE

SEC 4

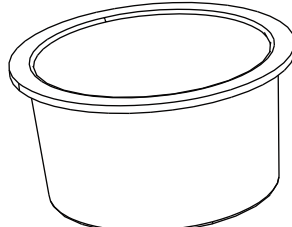

AZY (x2)

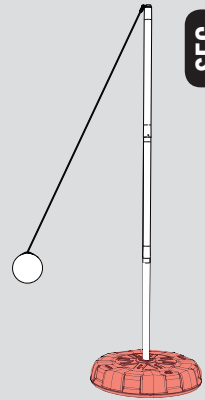

TWO ADULTS ARE REQUIRED TO COMPLETE ASSEMBLY. TO PREVENT SERIOUS INJURIES, THE POLE SHOULD BE HELD BY ONE ADULT AT ALL TIMES WHILE THE BASE IS BEING FILLED.

SEC

4.1

OPTION B: FILLING WITH WATER

- Add cold water up to the fill hole, leaving two inches of space at the top for expansion.
- Add one tablespoon of chlorine bleach to the water to prevent algae formation.
- Insert the **Base Caps (AZY)** into the fill holes.
- Using two adults, carefully stand the system up on a smooth surface.**

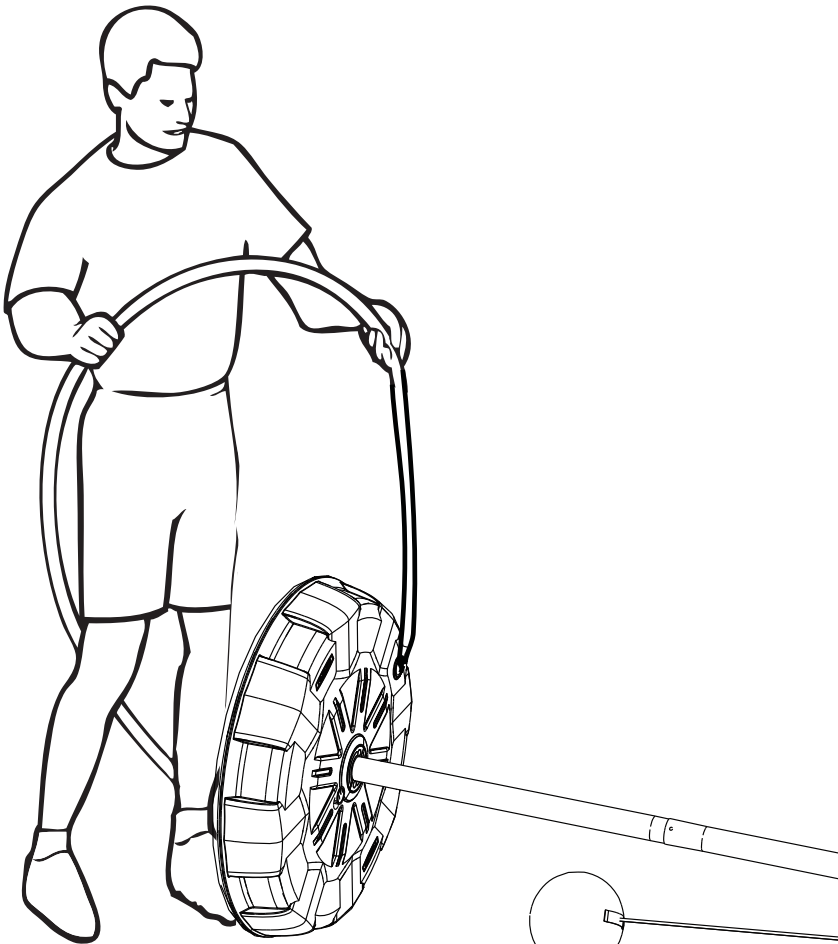

WARNING

For safety reasons, we recommend that sand be used instead of water to fill the Base. If a leak develops, water could run out unnoticed, allowing the system to fall over, resulting in serious personal injuries, or property damage. If using Water, check the Base carefully for leaks. If a leak is found, lay the system down on the ground and call Customer Service. Do not use, stand up, or play on a leaking system.



TOOLS AND HARDWARE REQUIRED FOR THIS PAGE

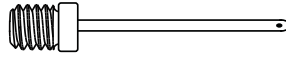
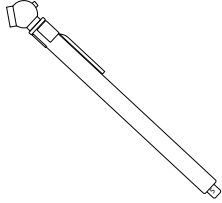

BFA (x1)

SEC 4

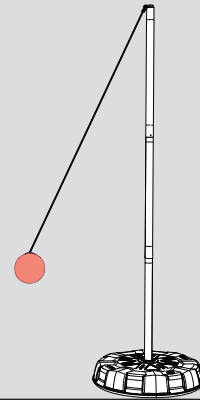

SEC

4.2

Connect **Ball Needle (BFA)** to a ball pump. Moisten Needle and carefully insert it into the Tetherball. Inflate Tetherball to 4 lbs. Check pressure with pressure gauge.

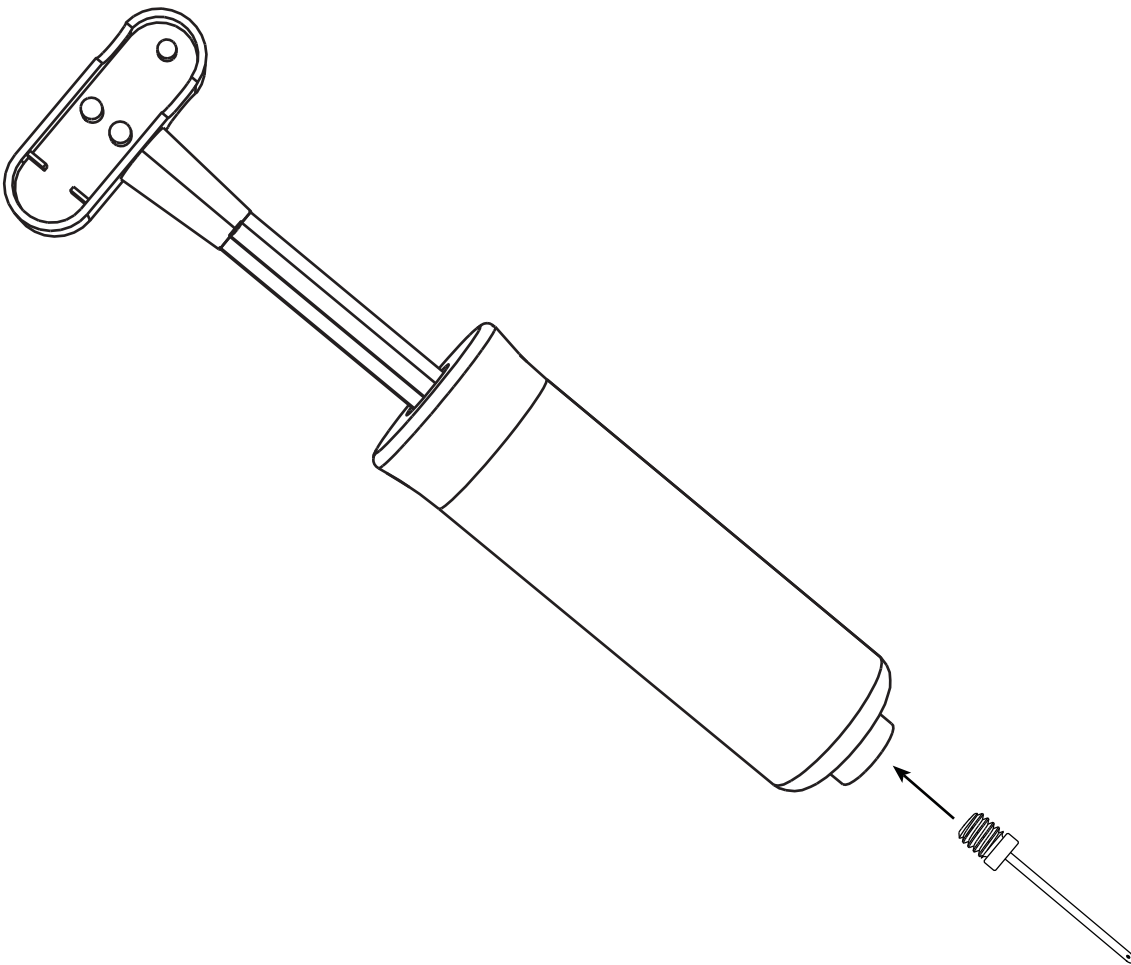

CAUTION

Use the Ball Pump provided to inflate the ball. Do not inflate with more than 4 lb. of air pressure. Overinflation and use of any other pump or compressor to inflate the ball may damage the system and will void the warranty.



Note: Pump included with your system may vary from the pump shown here. For pumps with hose attachments, connect Ball Needle to hose before inflating the ball.

SEC 5 TETHERBALL BASIC & ADVANCED RULES, & TACTICS

BASIC RULES

How the Game is Played: Play in matches of 3, 5, or 7 games. Each player takes a turn serving for a whole game. The serving player may serve the ball in either direction. The receiving player must then hit the ball in the opposite direction. After the initial serve, any player may hit the ball. To win a game, a player must completely wrap the rope around the pole in that player's direction. To win a match, a player must win by two or more games.

Non-Intentional Violations: If a violation occurs, the game is stopped and returned to the point at which the violation occurred. The non-offending player gets to serve. The following list explains the violations:

- **Stepping off sides:** Each player's field of play consists of only half the playing circle. A player may not step out of his or her boundaries.

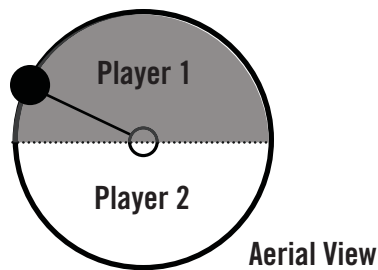

- **Touching the rope:** Players may not touch or hit the rope at any time.
- **Carrying or throwing the ball:** Players must only hit the ball when serving and receiving the ball. The ball must bounce off the players' hands or fists without any lingering contact.
- **Double hitting:** A player may hit the ball only once per wrap around the pole. If the ball hits the pole without going completely around the pole, the player may hit the ball again. However, a player may not hit the ball twice during a single revolution.

Committing three non-intentional violations, in any combination, during a single game, results in the loss of the game for the offending player.

Intentional Violations: A player must not grab the pole. Grabbing the pole is an automatic loss of the game for the offending player.

Double Violations: It is highly unlikely, but if both players commit a violation at the same time, the players must execute a "**Pole Drop**." A Pole Drop consists of both players holding the ball with one hand three feet from the pole along the line dividing the two sides. The players then release the ball simultaneously, and allow the ball to touch the pole before either player can hit the ball.

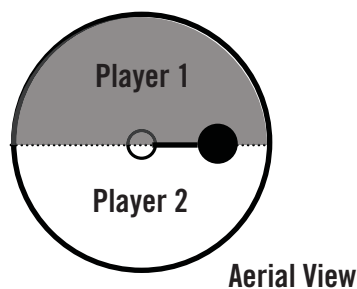

ADVANCED RULES

How the Game is Played: Play in matches of 3, 5, or 7 games. Each player takes a turn serving for a whole game. The serving player may serve the ball in either direction. The receiving player must allow the ball to swing around the pole at least once before striking the ball. The receiving player then hits the ball in the opposite direction. After the ball swings at least one time around the pole, any player may hit the ball.

Marking the Playing Area: Four Play Area markings are molded into the bottom of the tetherball base.

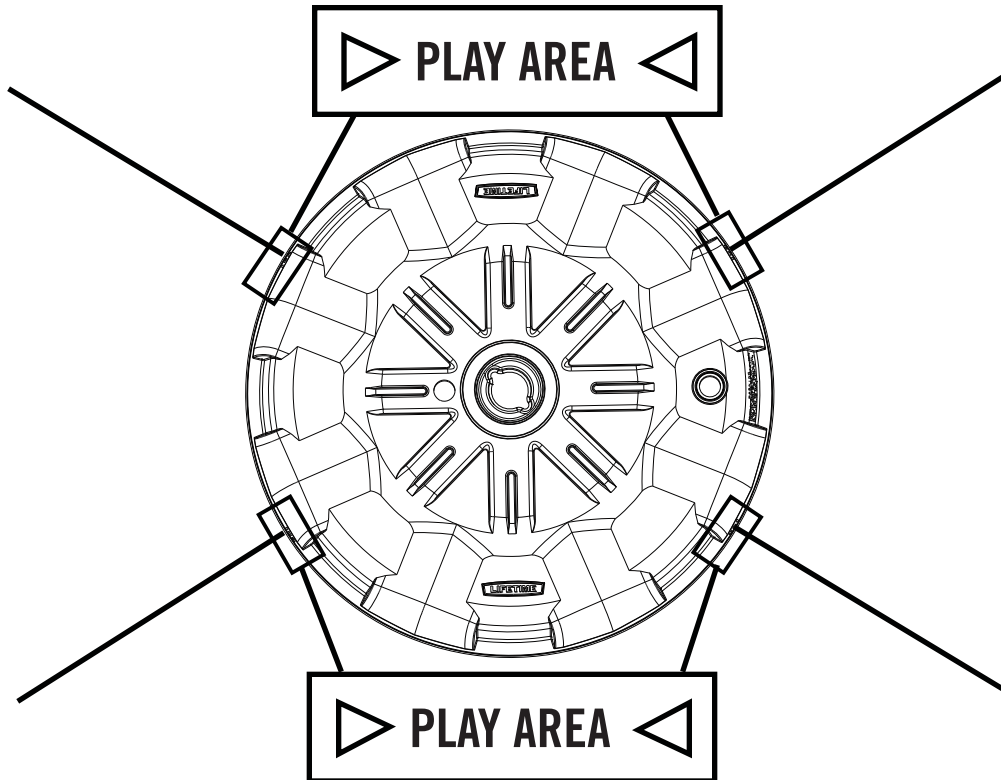

Draw chalk lines from the Play Area markings outward to create a playing field 20' in diameter. Mark off the Neutral Zone Areas with chalk.

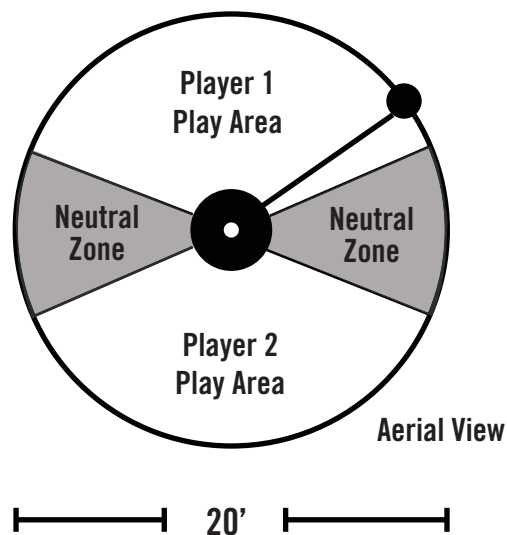

Neutral Zone Violations: Players must remain in their own Play Area. Neither player may step into the Neutral Zones or on a line of a Neutral Zone.

All other Non-intentional, Intentional, and Double Violations apply.

TETHERBALL TACTICS

To win the game, a player must keep the ball under his or her control. The following list explains some of the tactics used to get and keep control of the ball:

Serving: Power should not be your only technique. Try to serve the ball at extreme angles. This will help prevent your opponent from hitting the ball or hitting the ball well.

Stealing the Ball: A player steals the ball when he or she gains or regains control of the ball. Do not stay in the same place during play. This can set your opponent up to hit the ball at angles too difficult for you to hit at your current location. Change locations often. If your opponent does not know where you'll be standing, it's harder for him/her to form an offensive strategy. This approach can help set you up for steals. Sometimes the approaching ball comes at an angle that is too high or difficult to hit. It may be to your advantage to let the ball go around once unhindered or even hit the ball in your opponents direction to throw your opponent off and/or allow you to change your approach. This is known as a "Sacrifice Wrap." This will help set you up for a better hit in your direction.

Hitting Techniques: Predictability sets your opponent up to steal the ball and win the game or match. Change how and where you hit the ball by changing the speed and angle of the hit.

ENHANCE YOUR LIFETIME® PURCHASE BY ADDING ACCESSORIES OR OTHER GREAT PRODUCTS:

To purchase accessories or other Lifetime Products, visit us at:

www.lifetime.com

Or call: 1-800-424-3865

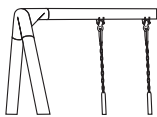

WARRANTY INFORMATION

LIFETIME TETHERBALL EQUIPMENT LIMITED FACTORY WARRANTY

THE MANUFACTURER RESERVES THE RIGHT TO MAKE SUBSTITUTIONS TO WARRANTY CLAIMS IF PARTS ARE UNAVAILABLE OR OBSOLETE.

1. The tetherball, cord, and clasp are warranted to the original purchaser to be free from defects in material and workmanship for a period of ninety days from the date of original purchase. All other parts are warranted to the original purchaser to be free from defects in material or workmanship for a period of five years from the date of original retail purchase. The word "defects" is defined as imperfections that impair the use of the product. Defects resulting from misuse, abuse or negligence will void this warranty. This warranty does not cover defects due to improper installation, alteration or accident. This warranty does not cover damage caused by vandalism, rusting, "acts of nature" or any other event beyond the control of the manufacturer.
2. This warranty is nontransferable and is expressly limited to the repair or replacement of defective tetherball equipment. If the equipment is defective within the terms of this warranty, Lifetime Products, Inc. will repair or replace defective parts at no cost to the purchaser. Shipping charges to and from the factory are not covered and are the responsibility of the purchaser. Labor charges and related expenses for removal, installation or replacement of the tetherball system or its components are not covered under this warranty.
3. This warranty does not cover scratching or scuffing of the product that may result from normal usage. In addition, defects resulting from intentional damage, negligence, unreasonable use or hanging from the tetherball or cord will void this warranty.
4. Liability for incidental or consequential damages is excluded to the extent permitted by law. While every attempt is made to embody the highest degree of safety in all equipment, freedom from injury cannot be guaranteed. The user assumes all risk of injury resulting from the use of this product. All merchandise is sold on this condition, and no representative of the company may waive or change this policy.
5. This product is not intended for institutional or commercial use; Lifetime Products, Inc. does not assume any liability for such use. Institutional or commercial use will void the warranty.
6. This warranty is expressly in lieu of all other warranties, expressed or implied, including warranties of merchantability or fitness for use to the extent permitted by Federal and state law. Neither Lifetime Products, Inc., nor any representative assumes any other liability in connection with this product. This warranty gives you specific legal rights, and you may also have other rights which vary from state to state.

ALL WARRANTY CLAIMS MUST BE ACCOMPANIED BY A SALES RECEIPT.

REPORT PRODUCT DEFECTS IN WRITING TO:

Lifetime Products, Inc., PO Box 160010 Clearfield, UT 84016-0010 or call (800) 225-3865 M-F 7 a.m. to 5 p.m. MST.

Please include your dated sales receipt and photographs of damaged parts.

To register the product, visit our Web site at www.lifetime.com



www.lifetime.com