

# **9000 Series**

**9000 SL**

**9000 XT**

**9000 XDT**

**9000XT Recliner**

**DEALER:** This manual **MUST** be given to the user of the wheelchair.

**USER:** **BEFORE** using this wheelchair, read this manual and save for future reference.

For more information regarding  
Invacare products, parts, and services,  
please visit [www.invacare.com](http://www.invacare.com)



**Yes, you can.**

---

---

## **⚠ WARNING**

**A QUALIFIED TECHNICIAN MUST PERFORM THE INITIAL SET UP OF THIS WHEELCHAIR. ALSO, A QUALIFIED TECHNICIAN MUST PERFORM ALL PROCEDURES SPECIFICALLY INDICATED IN THE MANUAL.**

**DO NOT USE THIS PRODUCT OR ANY AVAILABLE OPTIONAL EQUIPMENT WITHOUT FIRST COMPLETELY READING AND UNDERSTANDING THESE INSTRUCTIONS AND ANY ADDITIONAL INSTRUCTIONAL MATERIAL SUCH AS OWNER'S MANUALS, SERVICE MANUALS OR INSTRUCTION SHEETS SUPPLIED WITH THIS PRODUCT OR OPTIONAL EQUIPMENT. IF YOU ARE UNABLE TO UNDERSTAND THE WARNINGS, CAUTIONS OR INSTRUCTIONS, CONTACT A HEALTHCARE PROFESSIONAL, DEALER OR TECHNICAL PERSONNEL BEFORE ATTEMPTING TO USE THIS EQUIPMENT - OTHERWISE, INJURY OR DAMAGE MAY OCCUR.**

---

## **⚠ ACCESSORIES WARNING**

**INVACARE PRODUCTS ARE SPECIFICALLY DESIGNED AND MANUFACTURED FOR USE IN CONJUNCTION WITH INVACARE ACCESSORIES. ACCESSORIES DESIGNED BY OTHER MANUFACTURERS HAVE NOT BEEN TESTED BY INVACARE AND ARE NOT RECOMMENDED FOR USE WITH INVACARE PRODUCTS.**

---

*NOTE: Updated versions of this manual are available on [www.invacare.com](http://www.invacare.com).*

# TABLE OF CONTENTS

<b>REGISTER YOUR PRODUCT .....</b>	<b>6</b>
<b>SPECIAL NOTES .....</b>	<b>7</b>
<b>LABEL LOCATION .....</b>	<b>8</b>
<b>TYPICAL PRODUCT PARAMETERS .....</b>	<b>9</b>
<b>SECTION 1—GENERAL GUIDELINES .....</b>	<b>13</b>
Information for Healthcare Professionals/Assistants .....	13
Weight Training .....	13
Weight Limitation.....	13
Stability - All Models .....	14
Stability - Recliner Models Only .....	14
Anti-Tippers.....	15
Operating Information.....	15
Tire Pressure .....	16
<b>SECTION 2—SAFETY/HANDLING OF WHEELCHAIRS .....</b>	<b>17</b>
Safety/Handling of Wheelchairs.....	17
Stability and Balance.....	17
Coping With Everyday Obstacles.....	18
A Note to Wheelchair Assistants .....	18
Reaching, Leaning and Bending Forward.....	19
Reaching, Leaning Backwards.....	19
Tipping.....	20
Method 1 - Wheelchair With Step Tubes.....	20
Method 2 - Wheelchair Without Step Tubes .....	21
Stairways.....	22
Escalators.....	23
Transferring To and From Other Seats .....	23
Unfolding and Folding Wheelchair .....	24
Unfolding.....	24
Folding Hammock or Sling Seat Models .....	25
Folding Solid-Seat Models .....	25
<b>SECTION 3—SAFETY INSPECTION/TROUBLESHOOTING .....</b>	<b>26</b>
Safety Inspection Checklist.....	26
Inspect/Adjust Initially.....	26
Inspect/Adjust Weekly .....	27
Inspect/Adjust Monthly .....	27
Inspect/Adjust Periodically .....	28

# TABLE OF CONTENTS

Troubleshooting.....	28
Maintenance .....	29
Maintenance Safety Precautions .....	29
Suggested Maintenance Procedures .....	29
<b>SECTION 4—FRONT RIGGINGS .....</b>	<b>31</b>
Installing/Removing Front Riggings .....	31
Installing.....	31
Removing .....	31
Adjusting Footplate Height.....	32
Spring Button Height.....	32
Bolt-In-Place Height.....	32
Raising/Lowering Elevating Legrest Assembly.....	33
Installing Impact Guards/Calf Strap .....	34
Replacing Heel Loop.....	35
<b>SECTION 5—ARMS .....</b>	<b>37</b>
Adjusting Armrest Height.....	37
Using Swing-Back Arms.....	37
Removing or Replacing Armrest.....	38
Removing Armrests.....	38
Replacing Armrests.....	39
Replacing Desk/Full Length Armrest Pad (Fixed Height Arms Only) .....	39
Replacing Clothing Guards (Fixed Height Arms Only).....	39
Converting Between Space Saver and Conventional Arms.....	39
<b>SECTION 6—SEAT AND BACK .....</b>	<b>41</b>
Replacing Seat Upholstery .....	41
Replacing Back Upholstery .....	41
Screw-On Back Upholstery .....	41
Slip-On Back Upholstery .....	42
Adjusting Back Height, Back Angle or Seat Depth .....	43
Adjusting Seat Width.....	43
<b>SECTION 7—REAR WHEELS .....</b>	<b>44</b>
Removing/Installing Rear Wheels .....	44
Permanent Axles .....	44
Quick-Release Axles .....	44
Replacing Rear Wheel Handrim.....	46
Replacing/Repairing Rear Wheel Tire/Tube.....	46

# TABLE OF CONTENTS

Adjusting Quick-Release Axle .....	47
<b>SECTION 8—FRONT CASTERS .....</b>	<b>48</b>
Installing/Replacing Six or Eight-Inch Front Casters and Forks .....	48
Replacing/Repairing Front Caster Tire/Tube .....	49
Adjusting Front Caster Mounting .....	49
<b>SECTION 9—ANTI-TIPPERS/WHEEL LOCKS .....</b>	<b>50</b>
Installing/Adjusting Anti-tippers .....	50
Installing Anti-Tippers .....	50
Adjusting Anti-Tippers .....	51
Using/Adjusting Disk Wheel Locks .....	52
Using Patient Operated Disk Wheel Locks .....	52
Adjusting Patient-Operated Wheel Locks .....	53
Installing Wheel Lock Shoe Extensions .....	55
<b>SECTION 10—RECLINER .....</b>	<b>56</b>
Operating Recliner .....	56
Replacing Headrest Pillow .....	57
Replacing Headrest/Back Upholstery .....	58
Headrest Upholstery .....	58
Back Upholstery .....	58
Adjusting Headrest/Back Upholstery Tension .....	58
Adjusting Seat Depth .....	59
Adjusting Seat Width .....	59
Storing/Replacing Spreader Bar .....	60
Storing Spreader Bar .....	60
Removing From Stored Position .....	60
Placing In Stored Position .....	60
Replacing Spreader Bar .....	60
Installing Anti-Tippers .....	61
Removing/Installing Rear Wheels .....	61
With Patient Operated Wheel Locks .....	62
With Attendant Operated Wheel Locks .....	62
Using/Adjusting Wheel Locks .....	62
Using Attendant Operated Wheel Locks .....	62
Adjusting Attendant Operated Wheel Locks .....	63
Installing Telescoping I.V. Rod .....	64
Installing I.V. Holder .....	64
Installing I.V. Rod Support Tube .....	65
Adjusting I.V. Rod .....	65

# TABLE OF CONTENTS

<b>SECTION II—OPTIONS .....</b>	<b>67</b>
Installing/Cleaning Telescoping I.V. Rod/O2 Holders .....	67
Installing.....	67
Cleaning.....	68
Installing Crutch and Cane Carrier .....	69
Installing Amputee Bracket.....	69
Super Hemi Models .....	69
9000SL/XT .....	70
9000XDT .....	71
<b>LIMITED WARRANTY .....</b>	<b>75</b>

## REGISTER YOUR PRODUCT

The benefits of registering include:

1. Safeguarding your investment.
2. Ensuring long-term maintenance and servicing of your product.
3. Receiving updates with product information, maintenance tips and industry news.

**Register ONLINE at [warranty.invacare.com](http://warranty.invacare.com)**

Please have your model number and purchase date available to complete your registration.

Any registration information you submit will only be used by Invacare Corporation and protected as required by applicable laws and regulations.

# SPECIAL NOTES

Signal words are used in this manual and apply to hazards or unsafe practices which could result in personal injury or property damage. Refer to the following table for definitions of the signal words.

SIGNAL WORD	MEANING
DANGER	Danger indicates an imminently hazardous situation which, if not avoided, will result in death or serious injury.
WARNING	Warning indicates a potentially hazardous situation which, if not avoided, could result in death or serious injury.
CAUTION	Caution indicates a potentially hazardous situation which, if not avoided, may result in property damage or minor injury or both.

## NOTICE

**THE INFORMATION CONTAINED IN THIS DOCUMENT IS SUBJECT TO CHANGE WITHOUT NOTICE.**

### WHEELCHAIR USER

As a manufacturer of wheelchairs, Invacare endeavors to supply a wide variety of wheelchairs to meet many needs of the end user. However, final selection of the type of wheelchair to be used by an individual rests solely with the user and his/her healthcare professional capable of making such a selection.

### WHEELCHAIR TIE-DOWN RESTRAINTS AND SEAT RESTRAINTS

Wheelchair users should **NOT** be transported in vehicles of any kind while in wheelchairs. As of this date, the Department of Transportation has not approved any tie-down systems for transportation of a user while in a wheelchair, in a moving vehicle of any type.

It is Invacare's position that users of wheelchairs should be transferred into appropriate seating in vehicles for transportation and use be made of the restraints made available by the auto industry. Invacare cannot and does not recommend any wheelchair transportation systems.

### SEAT POSITIONING STRAP

**ALWAYS** wear your seat positioning strap. Inasmuch as the seat positioning strap is an option on this wheelchair (you may order with or without the seat positioning strap), Invacare strongly recommends ordering the seat positioning strap as an additional safeguard for the wheelchair user. The seat positioning strap is a positioning belt only. It is not designed for use as a safety device withstanding high stress loads such as auto or aircraft safety belts. If signs of wear appear, belt **MUST** be replaced **IMMEDIATELY**.

With regards to seat/chest positioning straps - it is the obligation of the **DME** dealer, therapists and other healthcare professionals to determine if a seat/chest positioning strap is required to ensure the safe operation of this equipment by the user. Serious injury can occur in the event of a fall from a wheelchair.

# LABEL LOCATION

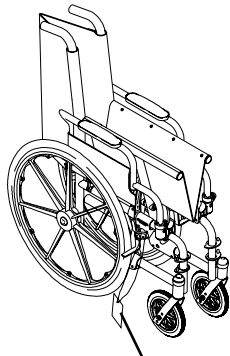

NO WHEELCHAIR HAS BEEN APPROVED FOR USE AS A SEATING SURFACE WITHIN A MOTOR VEHICLE. THIS LABEL IS FOR INFORMATIONAL PURPOSES ONLY. LIABILITY ISSUES WERE NOT CONSIDERED IN THE ATTACHMENT OF THIS LABEL.

AUCUN FAUTEUIL ROULANT N'A ÉTÉ APPROUVÉ POUR ÊTRE UTILISÉ COMME SIÈGE À L'INTÉRIEUR D'UN VÉHICULE MOTORISÉ. CETTE ÉTIQUETTE NE PEUT ÊTRE UTILISÉE QU'À TITRE D'INFORMATION ET N'A PAS ÉTÉ AFFICHÉE ICI POUR DES RAISONS DE RESPONSABILITÉ LÉGALE.

Serial Number Label is located on the cross brace on the left side of the chair

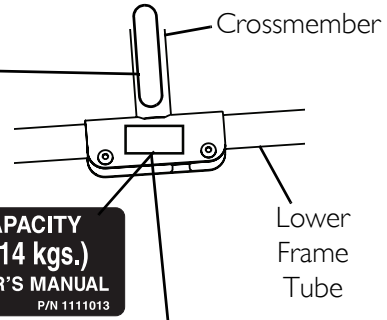

**WEIGHT CAPACITY**  
**250 LBS. (114 kgs.)**  
 REFER TO OWNER'S MANUAL  
 P/N 1111013

**WEIGHT CAPACITY**  
**350 LBS. (159 kgs.)**  
 REFER TO OWNER'S MANUAL  
 P/N 1111017

**9000 XDT Only**

**IMPORTANT NOTICE**

The wheel locks on this wheelchair have been pre-set at the factory to comply with the Veterans Administration functional Standard 8320.01 of the Federal Register, paragraph 3.2.4.5.3. If these wheel locks do not meet your needs, follow instructions below.

**CAUTION**

Any wheel lock adjustments should embed wheel lock shoe at least 1/8" into tire when locked (3/16" on pneumatic tires).

**INSTRUCTIONS FOR WHEEL LOCK ADJUSTMENTS**

- Loosen wheel lock mounting fastener, which runs through mounting bracket and frame.
- Slide clamp toward rear wheel until wheel lock shoe is embedded into tire material at least 1/8" when handle is engaged to the lock position (3/16" for pneumatic tires).
- Tighten mounting fastener to secure mounting bracket in desired location and recheck lock shoe embedding.
- Inspect for correct locking action BEFORE actual use.

00078X021-0394

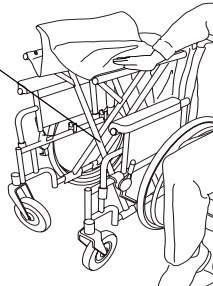

**9000 XT Recliner Models Only**

**WARNING**

DO NOT OPERATE WITHOUT THE ANTI-TIP TUBES INSTALLED. P/N 60106X144

REV. 5/98

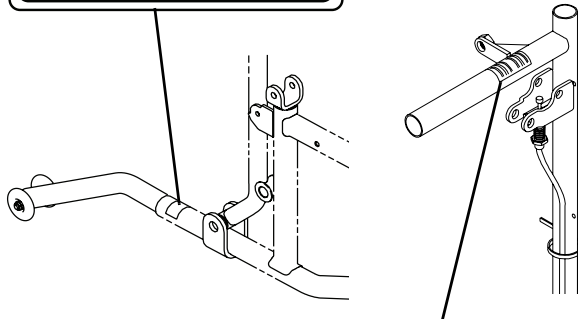

**CAUTION**

DO NOT recline without occupant. When the chair is not occupied the back will raise abruptly. Keep clear of the chair back when raising or lowering to avoid injury.

1023096

*NOTE: On all adjustable anti-tippers*

**WARNING**

Refer to Owner's Manual for proper anti-tipper setting.

1085379

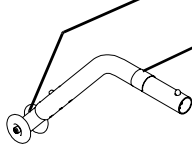

**WARNING**

DO NOT OPERATE WITHOUT THE ANTI-TIP TUBES INSTALLED. P/N 60106X144

REV. 5/98

**Models with Quick-Release Axles Only**

**WARNING**

DETENT BALLS MUST BE SECURELY SEATED IN RECESSED AREAS OF AXLE BUSHINGS. ENSURE THAT PLUNGER PIN IN HEAD END OF AXLE IS FULLY RELEASED. KEEP DETENT BALLS CLEAN.

1001948

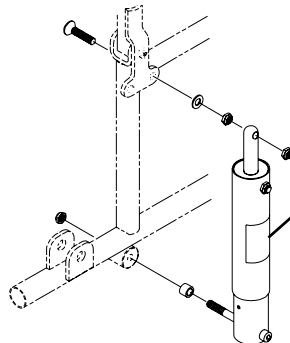
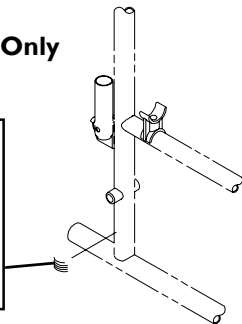

**CAUTION**

SERVICE OF SPRING LIFT MECHANISM TO BE PERFORMED BY PROPERLY TRAINED AUTHORIZED SERVICE PERSONNEL ONLY.

1022642



# TYPICAL PRODUCT PARAMETERS

9000 SL	
<b>OVERALL WIDTH</b>	23 or 25 inches
<b>OVERALL DEPTH (WITH RIGGINGS)</b>	43½ inches
<b>SEAT WIDTH</b>	16, 18 or 20 inches
<b>SEAT DEPTH</b>	16 or 18 inches
<b>SEAT-TO-FLOOR</b> TALL/ADULT: ADULT/HEMI: SUPER HEMI:	N/A 15½ to 19½ in 1-inch increments N/A
<b>BACK STYLE</b>	Sectional* - 1 inch increments; Adjustable angle - 85° to 110° in 5° increments
<b>BACK HEIGHT</b>	15 to 19 inches in 1-inch increments
<b>ARM STYLES</b>	Swing Back* Space Saver*, Desk* or full length in Fixed* or Adjustable Height Swing Back Removable, Conventional, Adjustable Height (Adjustable back angle style)
<b>FRONT RIGGINGS</b>	Swingaway footrests and elevating legrests
<b>REAR AXLE</b>	Permanent* and quick-release
<b>REAR WHEELS</b>	20, 22 and 24*-inch composite; Urethane*, pneumatic or pneumatic-flat free insert
<b>HANDRIMS</b>	Composite* and aluminum, steel
<b>WHEEL LOCKS</b>	Toggle lock -push or pull
<b>CASTER SIZE</b>	6 x 1-inch Urethane, 8 x 1¼-inch* Urethane, 8x1-inch solid rubber, and 8x1¼-inch pneumatic or pneumatic flat-free insert
<b>UPHOLSTERY</b>	Black nylon*, black vinyl
<b>FRAME COLORS</b>	Chrome* and colors
<b>WEIGHT (18 X 16 INCH SEAT)</b>	33½ lbs
<b>SHIPPING WEIGHT (APPROX.)</b> 16 X 16 INCH SEAT FRAME WITH COMPLETE PACKAGE	43 lbs
<b>WEIGHT LIMIT</b>	250 lbs (114 kg)

\*NOTE: These options are standard for this model.

\*\*NOTE: The seat-to-floor heights are based on urethane tires. If wheelchair is equipped with pneumatic (properly inflated) or solid rubber tires, add ¼-inch to the measurements listed above. These heights can vary +/- ¼-inch due to tire wear and manufacturing tolerances.

TYPICAL PRODUCT PARAMETERS

9000 XT	
<b>OVERALL WIDTH</b>	21, 22, 23, 25, 27 or 29 inches
<b>OVERALL DEPTH (WITH RIGGINGS)</b>	43½ inches
<b>SEAT WIDTH</b>	14, 15, 16, 18, 20 or 22 inches
<b>SEAT DEPTH</b>	16, 17, or 18 inches
<b>SEAT-TO-FLOOR</b> TALL/ADULT: ADULT/HEMI: SUPER HEMI:	N/A 15½ to 19½ in 1-inch increments 13½ and 14½ inches
<b>BACK STYLE</b>	Adjustable* - 1-inch increments Adjustable angle - 85° to 110° in 5° increments
<b>BACK HEIGHT</b>	15 to 19 inches in 1-inch increments
<b>ARM STYLES</b>	Swing back removable, space saver* or conventional in desk* or full length and in fixed* or adjustable height
<b>FRONT RIGGINGS</b>	Swingaway footrests and elevating legrests
<b>REAR AXLE</b>	Permanent* and quick-release
<b>REAR WHEELS</b>	20, 22 and 24*-inch composite; Urethane*, pneumatic or pneumatic-flat free insert
<b>HANDRIMS</b>	Composite*, aluminum, steel and plastic coated
<b>WHEEL LOCKS</b>	Toggle lock -push or pull
<b>CASTER SIZE</b>	6 x 1-inch Urethane, 8 x 1¼-inch* Urethane, 8x1-inch solid rubber, and 8x1¼-inch pneumatic or pneumatic flat-free insert, 8x1¾-inch semi pneumatic
<b>UPHOLSTERY</b>	Black nylon*, black sail cloth, heavy vinyl
<b>FRAME COLORS</b>	Chrome* and colors
<b>WEIGHT (18 X 16 INCH SEAT)</b>	31 lbs
<b>SHIPPING WEIGHT (APPROX.)</b> 16 X 16 INCH SEAT FRAME WITH COMPLETE PACKAGE	41½ lbs
<b>WEIGHT LIMIT</b>	250 lbs (114 kg)

\*NOTE: These options are standard for this model.

\*\*NOTE: The seat-to-floor heights are based on urethane tires. If wheelchair is equipped with pneumatic (properly inflated) or solid rubber tires, add ¼-inch to the measurements listed above. These heights can vary +/- ¼-inch due to tire wear and manufacturing tolerances.

9000 XT RECLINER	
<b>OVERALL WIDTH</b>	23, 25, 27, 28, 29 or 31 inches
<b>OVERALL DEPTH (WITH RIGGINGS)</b>	46 inches
<b>SEAT WIDTH</b>	14, 16, 18, 19, 20 or 22 inches
<b>SEAT DEPTH</b>	16, 17, or 18 inches
<b>SEAT-TO-FLOOR**</b> TALL/ADULT: ADULT/HEMI: SUPER HEMI:	17½ to 19½ inches in 1-inch increments N/A N/A
<b>BACK STYLE</b>	Reclining
<b>BACK HEIGHT</b>	23 or 24 inches
<b>ARM STYLES</b>	Conventional Desk* or full length and in fixed* or adjustable height
<b>FRONT RIGGINGS</b>	Swingaway footrests and elevating legrests
<b>REAR AXLE</b>	Permanent
<b>REAR WHEELS</b>	20, 22 and 24*-inch composite*; Urethane*, pneumatic or pneumatic-flat free insert
<b>HANDRIMS</b>	Composite*, aluminum, steel and plastic coated
<b>WHEEL LOCKS</b>	Toggle lock - push or pull
<b>CASTER SIZE</b>	8 x 1¼-inch* Urethane, 8x1-inch solid rubber, and 8x1¼-inch pneumatic or pneumatic flat-free insert, 8x1¾-inch semi pneumatic
<b>UPHOLSTERY</b>	Heavy vinyl, light vinyl, nylon, sail cloth
<b>FRAME COLORS</b>	Chrome and colors
<b>WEIGHT</b>	50½ lbs
<b>SHIPPING WEIGHT (APPROX.)</b>	60½ lbs 18x17-inch seat frame with complete package
<b>WEIGHT LIMIT</b>	250 lbs (114 kg)

\*NOTE: These options are standard for this model.

\*\*NOTE: The seat-to-floor heights are based on pneumatic tires and pneumatic tires with flat free inserts. If wheelchair is equipped with urethane tires, subtract ¼-inch from the measurements listed above. All heights are measured with properly inflated new tires. These heights can vary ± ¼-inch due to tire wear.

TYPICAL PRODUCT PARAMETERS

9000 XDT	
<b>OVERALL WIDTH</b>	23, 25, 27 or 29 inches
<b>OVERALL DEPTH (WITH RIGGINGS)</b>	45½ inches
<b>SEAT WIDTH</b>	16, 18, 20 or 22 inches
<b>SEAT DEPTH</b>	16, 17, 18, 19 and 20 inches
<b>SEAT-TO-FLOOR**</b> TALL/ADULT: ADULT/HEMI: SUPER HEMI:	17½, 19½ and 21½ inches N/A N/A
<b>BACK STYLE</b>	Adjustable - 1-inch increments
<b>BACK HEIGHT</b>	15 to 19 inches in 1-inch increments
<b>ARM STYLES</b>	Swing back or removable, space saver* or conventional, desk* or full length and in fixed* or adjustable height
<b>FRONT RIGGINGS</b>	Swingaway footrests and elevating legrests
<b>REAR AXLE</b>	Permanent
<b>REAR WHEELS</b>	24*-inch composite, urethane*, pneumatic or pneumatic-flat free insert
<b>HANDRIMS</b>	Steel*, aluminum and plastic coated
<b>WHEEL LOCKS</b>	Toggle lock - push or pull
<b>CASTER SIZE</b>	8 x 1¼-inch* Urethane, 8x1-inch solid rubber, and 8x1¼-inch pneumatic or pneumatic flat-free insert, 8x1¾-inch semi pneumatic
<b>UPHOLSTERY</b>	Black nylon, black sail cloth, heavy vinyl
<b>FRAME COLORS</b>	Chrome and colors
<b>WEIGHT</b>	36½ lbs
<b>SHIPPING WEIGHT (APPROX.)</b>	46½ lbs 16x16-inch seat frame with complete package
<b>WEIGHT LIMIT</b>	350 lbs (154 kg)

\*NOTE: These options are standard for this model.

\*\*NOTE: The seat-to-floor heights are based on pneumatic tires and pneumatic tires with flat free inserts. If wheelchair is equipped with urethane tires, subtract ¼-inch from the measurements listed above. All heights are measured with properly inflated new tires. These heights can vary ± ¼-inch due to tire wear.

---

# SECTION I—GENERAL GUIDELINES

---

## **⚠ WARNING**

**SECTION I - GENERAL GUIDELINES** contains important information for the safe operation and use of this product.

---

## **Information for Healthcare Professionals/Assistants**

Make sure the patient is properly positioned in the wheelchair before reclining or inclining (reverse recline) to maintain maximum stability and safety. Refer to Safety/Handling of Wheelchairs on page 17.

Make sure occupant's hands and body are clear of all pinch points before reclining back. Pinch Points exist between spreader bar and recliner mechanism. Use caution, otherwise injury may occur.

ALWAYS engage both wheel locks while reclining or inclining (reverse recline) the wheelchair.

When returning the occupant of the reclining back wheelchair to the full upright position, more body strength will be required for approximately the last twenty degrees of incline (reverse recline). Make sure to use proper body mechanics (use your legs) or seek assistance if necessary to avoid injury.

DO NOT attempt to recline or incline the wheelchair back without occupant. Back will raise abruptly and cause injury. Keep clear when reclining or inclining chair back to avoid injury.

## **Weight Training**

Invacare does not recommend the use of its wheelchairs as a weight training apparatus. Invacare wheelchairs have not been designed or tested as a seat for any kind of weight training. If occupant uses said wheelchair as a weight training apparatus, Invacare shall not be liable for bodily injury or damage to the wheelchair and the warranty is void.

## **Weight Limitation**

The 9000 SL, 9000 XT, and 9000XT Recliner wheelchairs have a weight limitation of 250 lbs (114 kg). The 9000XDT wheelchair has a weight limitation of 350 lbs (159 kg).

## Stability - All Models

The seat depth, back height/angle, seat angle, size/position of the front casters, size/position of the rear wheels, anti-tipper model, as well as the user condition directly relate to the stability of the wheelchair. Any change to one or any combination of the ten may cause the wheelchair to decrease in stability. These adjustments **MUST** be performed by a qualified technician.

<i>NOTE: When changes to the left hand column occur, follow across the chart and refer to the X procedure to maintain the proper stability, safety and handling of the wheelchair.</i>	BACK HEIGHT	SEAT DEPTH	BACK ANGLE	SEATING SYSTEM	TILT ANGLE	CASTER SIZE	CASTER POSITION	WHEEL SIZE	WHEEL POSITION	USER CONDITION	WHEEL LOCKS	ANTI-TIPPERS
<b>BACK HEIGHT</b>	•	X	X	X	X	X	X	X	X	N/A	N/A	N/A
<b>SEAT DEPTH</b>	X	•	X	X	N/A	X	X	X	X	N/A	N/A	N/A
<b>BACK ANGLE</b>	X	X	•	X	X	X	X	X	X	N/A	N/A	N/A
<b>SEATING SYSTEM</b>	X	X	X	•	X	X	X	X	X	X	N/A	N/A
<b>TILT ANGLE</b>	N/A	N/A	X	N/A	•	N/A	N/A	N/A	N/A	N/A	N/A	N/A
<b>CASTER SIZE</b>	X	N/A	X	N/A	N/A	•	X	X	X	N/A	X	X
<b>CASTER POSITION</b>	X	N/A	X	N/A	N/A	X	•	X	X	N/A	X	X
<b>WHEEL SIZE</b>	X	N/A	X	N/A	N/A	X	X	•	X	N/A	X	X
<b>WHEEL POSITION</b>	X	N/A	X	N/A	N/A	X	X	X	•	N/A	X	X
<b>USER CONDITION</b>	X	X	X	X	X	X	X	X	X	•	N/A	N/A
<b>SEAT HEIGHT</b>	X	N/A	X	X	X	X	X	X	X	N/A	X	X

The various seat-to-floor heights require specific settings depending on rear wheel size, rear wheel position, front caster size/position and desired seat-to-floor angle. These adjustments **MUST** be performed by a qualified technician.

### Stability - Recliner Models Only

ALWAYS use anti-tippers. When outdoors on wet, soft ground or on gravel surfaces, anti-tippers may not provide the same level of protection against tipover. Extra caution **MUST** be observed when traversing such surfaces.

ALWAYS make sure that the wheelchair is stable before using the recliner option.

Ensure the spreader bar is attached and secured before using the 9000XT Recliner.

ALWAYS return the back to the upright position before lifting the wheelchair.

LIFT KIT MODELS ONLY - Both spring lift mechanisms **MUST** be operational before using the recliner. **DO NOT** operate the recliner option if only one of the spring lift mechanisms is operational.

LIFT KIT MODELS ONLY - **DO NOT** attempt to recline or incline the wheelchair back without occupant. Back will raise abruptly and cause injury. Keep clear when reclining or inclining chair back to avoid injury.

## Anti-Tippers

Anti-tippers are specific to the different seat-to-floor angles and/or seat-to-floor heights. Refer to the charts in Installing/Adjusting Anti-tippers on page 50 for correct usage and adjustment. If these requirements cannot be achieved, DO NOT use the wheelchair. Contact a qualified technician. If changing the seat-to-floor height with or without a change to seat-to-floor angle, the correct anti-tippers MUST be used to maintain a 1½ to 2-inch ground clearance.

Seat-to-floor angle of 0° or 3°: If so equipped, anti-tippers MUST be attached at all times. Inasmuch as the anti-tippers are an option for 0° or 3° on this wheelchair (you may order with or without the anti-tippers), Invacare strongly recommends ordering the anti-tippers as a safeguard for the wheelchair user.

Seat-to-floor angle of 6°: If changing the seat-to-floor angle to 6°, anti-tippers MUST be installed.

ALWAYS use anti-tippers. When outdoors on wet, soft ground or on gravel surfaces, anti tippers may not provide the same level of protection against tipover. Extra caution MUST be observed when traversing such surfaces.

## Operating Information

Unless otherwise noted, all service and adjustment should be performed while the wheelchair is unoccupied.

To determine and establish your particular safety limits, practice bending, reaching and transferring activities in several combinations in the presence of a qualified healthcare professional before attempting active use of the wheelchair.

When cleaning rear cane or hand grip areas use only a clean towel lightly dampened with cool water. Verify that grips are dry prior to use. Use of soap or ammonia based cleaning solutions will result in the hand grips sliding off the cane assembly. Failure to observe this warning may result in injury to the user or bystanders.

If the wheelchair is exposed to extreme temperature (above 100°F or below 32°F), high humidity and/or becomes wet, prior to use, ensure that the handgrips DO NOT twist on the handle. Otherwise, damage or injury may occur.

DO NOT sit or transfer into the wheelchair unless it is fully open and the seat frame rails are fully seated into the side frame H-blocks.

Avoid storing or using the wheelchair near open flame or combustible products. Serious injury or damage to property may result.

DO NOT traverse, climb or go down ramps or slopes greater than 9°.

DO NOT attempt to move up or down an incline with a water, ice or oil film.

DO NOT operate on roads, streets or highways.

DO NOT attempt to ride over curbs or obstacles. Doing so may cause your wheelchair to tip over and cause bodily harm to you or damage to the wheelchair.

DO NOT attempt to reach objects if you have to move forward in the seat.

DO NOT attempt to reach objects if you have to pick them up from the floor by reaching down between your knees.

DO NOT lean over the top of the back upholstery to reach objects behind you, as this may cause the wheelchair to tip over.

DO NOT shift your weight or sitting position toward direction you are reaching as the wheelchair may tip over.

DO NOT attempt to stop a moving wheelchair with wheel locks. Wheel locks are not brakes.

DO NOT tip the wheelchair without assistance.

DO NOT use an escalator to move a wheelchair between floors. Serious bodily injury may occur.

Before attempting to transfer in or out of the wheelchair, every precaution should be taken to reduce the gap distance. Turn both casters parallel to the object you are transferring onto. When transferring to and from the wheelchair, ALWAYS engage both wheel locks.

DO NOT attempt to lift the wheelchair by any removable (detachable) parts. Lifting by means of any removable (detachable) parts of the wheelchair may result in injury to the user or damage to the wheelchair.

9000 XT RECLINER ONLY - DO NOT use the spreader bar to lift the wheelchair. Refer to [Storing/Replacing Spreader Bar](#) on page 60.

DO NOT stand on the frame of the wheelchair.

DO NOT use the footplate as a platform. When getting in or out of the wheelchair, make sure that the footplates are in the upward position.

NEVER use quick-release axles on the 9000 XT (models with offset axle option ONLY), 9000XDT or 9000XT RECLINER wheelchairs.

ALWAYS use the handrims for self-propulsion. Inasmuch as the HANDRIMS are an option on this wheelchair (you may order with or without the handrims), Invacare strongly recommends ordering the handrims as an additional safeguard for the wheelchair user.

Invacare recommends that a non-folding device be installed to keep the wheelchair from being folded when left unoccupied in a public place.

## Tire Pressure

DO NOT use your wheelchair unless it has the proper tire pressure (p.s.i.). DO NOT overinflate the tires. Failure to follow these suggestions may cause the tire to explode and cause bodily harm. The recommended tire pressure is listed on the side wall of the tire.

Replacement of a pneumatic tire or tube MUST be performed by a qualified technician.



# SECTION 2—SAFETY/HANDLING OF WHEELCHAIRS

## Safety/Handling of Wheelchairs

Safety and handling of the wheelchair require the close attention of the wheelchair user as well as the assistant. This manual points out the most common procedures and techniques involved in the safe operation and maintenance of the wheelchair. It is important to practice and master these safe techniques until you are comfortable in maneuvering around the frequently encountered architectural barriers.

Use this information only as a basic guide. The techniques that are discussed on the following pages have been used successfully by many.

Individual wheelchair users often develop skills to deal with daily living activities that may differ from those described in this manual. Invacare recognizes and encourages each individual to try what works best for him/her in overcoming architectural obstacles that they may encounter. However, all warnings and cautions given in this manual **MUST** be heeded. Techniques in this manual are a starting point for the new wheelchair user and assistant with “safety” as the most important consideration for all.

## Stability and Balance

---

### **⚠ WARNING**

**ALWAYS** wear your seat positioning strap. Inasmuch as the seat positioning strap is an option on this wheelchair (you may order with or without the seat positioning strap), Invacare strongly recommends ordering the seat positioning strap as an additional safeguard for the wheelchair user. The seat positioning strap is a positioning belt only. It is not designed for use as a safety device withstanding high stress loads such as auto or aircraft safety belts. If signs of wear appear, belt **MUST** be replaced **IMMEDIATELY**.

---

### **⚠ WARNING**

Be aware that carrying heavy objects on your lap while occupying the wheelchair may adversely affect the stability of the wheelchair, resulting in serious bodily injury to the user, damage to the wheelchair and surrounding property.

---

### **⚠ WARNING**

This wheelchair has been designed to accommodate one individual. If more than one individual occupies the wheelchair this may adversely affect the stability of the wheelchair, resulting in serious bodily injury to the user and passenger and damage to the wheelchair and surrounding property.

---

To assure stability and proper operation of your wheelchair, you **MUST** maintain proper balance at all times. Your wheelchair has been designed to remain upright and stable during normal daily activities as long as you **DO NOT** move beyond the center of gravity.

Virtually all activities which involve movement in the wheelchair have an effect on the center of gravity. Invacare recommends using seat/chest positioning straps for additional safety while involved in activities that shift your weight.

**DO NOT** lean forward out of the wheelchair any further than the length of the armrests. Make sure the casters are pointing in the forward position whenever you lean forward. This can be achieved by advancing the wheelchair and then reversing it in a straight line.

## Coping With Everyday Obstacles

Coping with the irritation of everyday obstacles can be alleviated somewhat by learning how to manage your wheelchair. Keep in mind your center of gravity to maintain stability and balance.

## A Note to Wheelchair Assistants

When assistance to the wheelchair user is required, remember to use good body mechanics. Keep your back straight and bend your knees whenever tipping the wheelchair or traversing curbs, or other impediments.

**DO NOT** attempt to lift the wheelchair by any removable (detachable) parts. Lifting by means of any removable (detachable) parts of the wheelchair may result in injury to the user or damage to the wheelchair.

**ALWAYS** check hand grips for looseness before using the wheelchair. If loose and/or worn, replace **IMMEDIATELY**.

**9000 XT RECLINER ONLY - DO NOT** use the spreader bar to lift the wheelchair.

Also, be aware of detachable parts such as the spreader bar (**9000 XT RECLINER ONLY**), armrests or legrests. These **MUST NEVER** be used to move the wheelchair or as lifting supports, as they may be inadvertently released, resulting in possible injury to the user and/or assistant(s).

When learning a new assistance technique, have an experienced assistant help you before attempting it alone.

---

### **⚠ WARNING**

**DO NOT** attempt to reach objects if you have to move forward in the seat or pick them up from the floor by reaching down between your knees.

**The seat depth, back height/angle, seat angle, size/position of the front casters, size/position of the rear wheels, anti-tipper model, as well as the user condition directly relate to the stability of the wheelchair. Any change to one or any combination of the ten may cause the wheelchair to decrease in stability. These adjustments MUST be performed by a qualified technician.**

Many activities require the wheelchair owner to reach, bend and transfer in and out of the wheelchair. These movements will cause a change to the normal balance, the center of gravity, and the weight distribution of the wheelchair. To determine and establish your particular safety limits, practice bending, reaching and transferring activities in several combinations in the presence of a qualified healthcare professional before attempting active use of the wheelchair.

Proper positioning is essential for your safety. When reaching, leaning, or bending forward, it is important to use the front casters as a tool to maintain stability and balance.

## Reaching, Leaning and Bending Forward

### **⚠ WARNING**

**DO NOT attempt to reach objects if you have to move forward in the seat or pick them up from the floor by reaching down between your knees.**

*NOTE: For this procedure, refer to FIGURE 2.1.*

Position the front casters so that they are extended as far forward as possible and engage wheel locks.

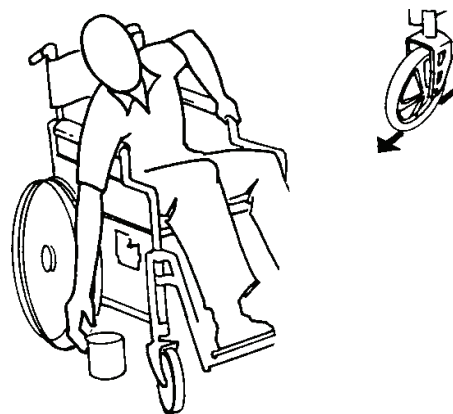

**FIGURE 2.1** Reaching, Leaning and Bending Forward

## Reaching, Leaning Backwards

### **⚠ WARNING**

**DO NOT lean over the top of the back upholstery to reach objects behind you, as this may cause the wheelchair to tip over.**

*NOTE: For this procedure, refer to FIGURE 2.2.*

Position wheelchair as close as possible to the desired object. Point front casters forward to create the longest possible wheelbase. Reach back only as far as your arm will extend without changing your sitting position.



**FIGURE 2.2** Reaching, Leaning Backwards

## Tipping

### **⚠ WARNING**

**DO NOT tip the wheelchair without assistance.**

When tipping the wheelchair, an assistant should grasp the back of the wheelchair on a non-removable (non-detachable) part. Inform the wheelchair occupant before tipping the wheelchair and remind him/her to lean back. Be sure the occupant's feet and hands are clear of all wheels and/or pinch points.

After mastering the techniques of tipping the wheelchair, use one of the following methods to tackle curbs, short stairs, etc.

### **Method I - Wheelchair With Step Tubes**

*NOTE: For this procedure, refer to FIGURE 2.3.*

Place foot on the step tube and begin to tilt the wheelchair toward you. Apply a continuous downward motion until the balance point is achieved and the front casters clear the curb. At this point, the assistant will feel a difference in the weight distribution.

### **⚠ WARNING**

**When lowering the front casters of the wheelchair, DO NOT let the wheelchair drop the last few inches to the ground. This could result in injury to the occupant and/or damage to the wheelchair.**

Roll the wheelchair forward and slowly lower the front of the wheelchair in one continuous movement onto the sidewalk. Push the wheelchair forward until the rear wheels roll up and over the curb.

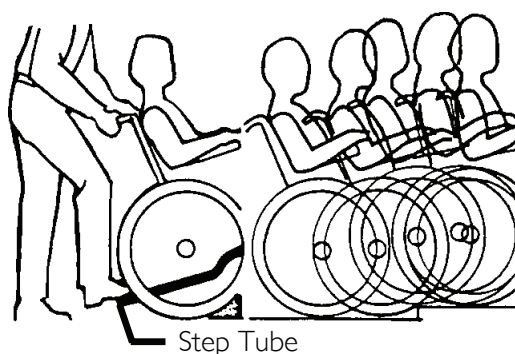

**FIGURE 2.3** Method I - Wheelchair With Step Tubes

---

## Method 2 - Wheelchair Without Step Tubes

---

### **⚠ WARNING**

**ALWAYS** check hand grips for looseness before using the wheelchair. If loose and/or worn, replace **IMMEDIATELY**.

---

*NOTE: For this procedure, refer to FIGURE 2.4.*

This method requires two assistants. The second assistant should be positioned at the front of the wheelchair lifting upward on a non-removable (non-detachable) part of the wheelchair frame when lifting the wheelchair and stabilizing the wheelchair when the wheelchair is being lowered to the ground.

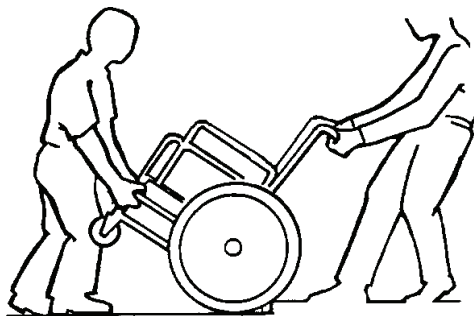

**FIGURE 2.4** Method 2 - Wheelchair Without Step Tubes

The first assistant should stand on the sidewalk and turn the wheelchair so that the rear wheels are against the curb. Turn the anti-tippers so the anti-tip wheels are pointing up. The wheelchair should be tilted back to the balance point and, in one continuous upward movement, the rear wheels should be pulled up and over the curb. **DO NOT** return the front casters to the ground until the wheelchair has been pulled backward far enough for the front casters to clear the edge of the curb.

---

### **⚠ WARNING**

**When lowering the front casters of the wheelchair, DO NOT** let the wheelchair drop the last few inches to the ground. This could result in injury to the occupant and/or damage to the wheelchair.

---

Roll the wheelchair backward and slowly lower the wheelchair in one continuous movement. Turn the anti-tippers so the anti-tip wheels are facing down.

## Stairways

### ⚠ WARNING

**ALWAYS** wear your seat positioning strap. Inasmuch as the seat positioning strap is an option on this wheelchair (you may order with or without the seat positioning strap), Invacare strongly recommends ordering the seat positioning strap as an additional safeguard for the wheelchair user. The seat positioning strap is a positioning belt only. It is not designed for use as a safety device withstanding high stress loads such as auto or aircraft safety belts. If signs of wear appear, belt **MUST** be replaced **IMMEDIATELY**.

**DO NOT** attempt to lift a wheelchair by lifting on any removable (detachable) parts. Lifting by means of any removable (detachable) parts of the wheelchair may result in injury to the user or damage to the wheelchair.

**ALWAYS** check hand grips for looseness before using the wheelchair. If loose and/or worn, replace **IMMEDIATELY**.

Extreme caution is advised when it is necessary to move an occupied wheelchair up or down the stairs. Invacare recommends that, if possible, the user be removed from the wheelchair prior to moving. Invacare recommends using two assistants and making thorough preparations. Make sure to use only secure, non-detachable parts for hand-held supports.

**9000 XT recliner only - ALWAYS** return the back to the upright position before lifting the wheelchair.

*NOTE: For this procedure, refer to FIGURE 2.5.*

Follow this procedure for moving the wheelchair between floors when an elevator is not available:

1. If necessary, rotate the anti-tippers so the wheels are facing up.
2. After the wheelchair has been tilted back to the balance point, one assistant (in the rear) backs the wheelchair up against the first step, while securely grasping a non-removable (non-detachable) part of the wheelchair for leverage.
3. The second assistant, with a firm hold on a non-detachable part of the framework, lifts the wheelchair up and over the stair and steadies the wheelchair as the first assistant places one foot on the next stair and repeats STEP 1.
4. The wheelchair should not be lowered until the last stair has been negotiated and the wheelchair has been rolled away from the stairway.
5. If necessary, rotate the anti-tippers so the wheels are facing down.

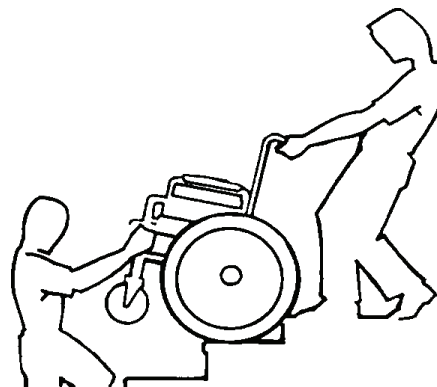

**FIGURE 2.5** Stairways

---

## Escalators

---

### **⚠ WARNING**

**DO NOT** use an escalator to move a wheelchair between floors. Serious bodily injury may occur.

---

## Transferring To and From Other Seats

---

### **⚠ WARNING**

Before attempting to transfer in or out of the wheelchair, every precaution should be taken to reduce the gap distance. Turn both casters parallel to the object you are transferring onto. Also be certain the wheel locks are engaged to help prevent the wheels from moving.

---

### **CAUTION**

When transferring, position yourself as far back as possible in the seat. This will help prevent damaged upholstery and the possibility of the wheelchair tipping forward.

---

*NOTE: For this procedure, refer to FIGURE 2.6.*

*NOTE: This activity may be performed independently provided you have adequate mobility and upper body strength.*

Position the wheelchair as close as possible alongside the seat to which you are transferring, with the front casters pointing parallel to it. Remove or flip up the armrest. Engage wheel locks. Swing away or remove front rigging. Shift body weight into seat with transfer.

During independent transfer, little or no seat platform will be beneath you. Use a transfer board if at all possible.



**FIGURE 2.6** Transferring To and From Other Seats

## Unfolding and Folding Wheelchair

---

### **⚠ WARNING**

**ALWAYS** keep hands and fingers clear of moving parts to avoid injury.

**DO NOT** place hand or fingers on the underside of the seat frame rail when opening or closing the wheelchair.

**DO NOT** sit or transfer into the wheelchair unless it is fully open and the seat frame rails are fully seated into the side frame H-blocks.

---

*NOTE: For this procedure, refer to FIGURE 2.7.*

### Unfolding

1. Tilt the wheelchair toward you (raising the opposite wheel and caster off the ground/floor).
2. Place your hand on the top of the seat rail closest to you where the seat upholstery is attached.
3. Point your fingers and thumb to the inside of the wheelchair.
4. Press downward on the top of the seat rail until the wheelchair is fully open and the seat rails are fully seated in the H-blocks.

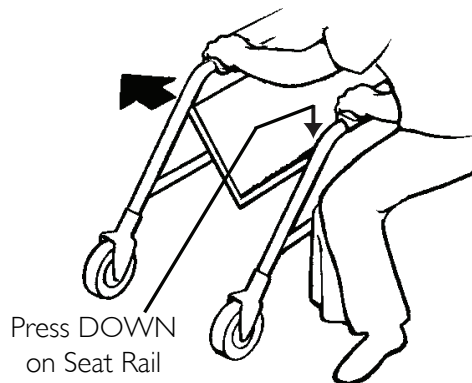

**FIGURE 2.7** Unfolding and Folding Wheelchair

5. 9000 XT RECLINERS ONLY - Secure the detached end of the spreader bar to the side frame. Refer to Storing/Replacing Spreader Bar on page 60.
6. Engage both wheel locks, open the footrest/legrest for clearance and transfer into the wheelchair. Refer to Transferring To and From Other Seats on page 23.



## Folding Hammock or Sling Seat Models

*NOTE: For this procedure, refer to FIGURE 2.8.*

1. 9000 XT RECLINERS ONLY - Detach one end of the spreader bar from the side frame. Refer to [Storing/Replacing Spreader Bar](#) on page 60.
2. Swing footrest/legrest in locked position to the front of the wheelchair.
3. Pivot footplates upward to vertical position.
4. With both hands, grasp the middle of the seat upholstery at the front and back edge and lift up.
5. Continue to close the wheelchair by grasping the armrest furthest from you and pulling the armrest towards you.

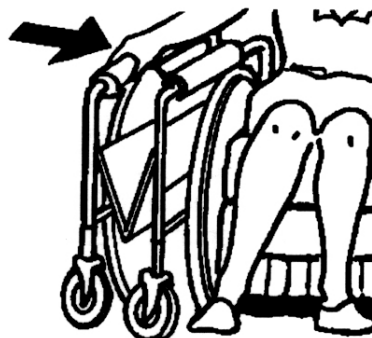
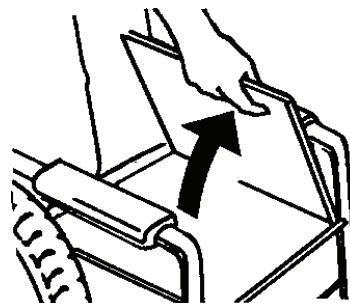

**FIGURE 2.8** Folding Hammock or Sling Seat Models

## Folding Solid-Seat Models

*NOTE: For this procedure, refer to FIGURE 2.9*

1. 9000 XT RECLINERS ONLY - Detach one end of the spreader bar from the side frame. Refer to [Storing/Replacing Spreader Bar](#) on page 60.
2. Swing footrest/legrest in locked position to the front of the wheelchair.
3. Pivot footplates upward to vertical position.
4. From behind the wheelchair, grasp the right hand edge of the solid seat.
5. Raise the seat to the hinged side.
6. With both hands, grasp the middle of the front and back edges of the solid folding seat and lift up until the wheelchair begins to close.
7. Continue to close the wheelchair by grasping the armrest furthest from you and pulling the armrest towards you.



**FIGURE 2.9** Folding Solid-Seat Models

# SECTION 3—SAFETY INSPECTION/TROUBLESHOOTING

*NOTE: Every six months or as necessary, take your wheelchair to a qualified technician for a thorough inspection and servicing. Regular cleaning will reveal loose or worn parts and enhance the smooth operation of your wheelchair. To operate properly and safely, your wheelchair MUST be cared for just like any other vehicle. Routine maintenance will extend the life and efficiency of your wheelchair.*

## Safety Inspection Checklist

Initial adjustments should be made to suit your personal body structure and preference. Thereafter follow these maintenance procedures:

### Inspect/Adjust Initially

- Ensure that the wheelchair rolls straight (no excessive drag or pull to one side).
- Inspect for loose or missing hardware on frame and crossbraces.
- Inspect for bent frame or crossbraces.
- Check that the wheel locks DO NOT interfere with tires when rolling.
- Check that the wheel lock pivot points are free of wear and looseness.
- Check that the wheel locks are easy to engage.
- Ensure that the wheel locks prevent the wheelchair from moving when engaged.
- Inspect the seat and back for rips and sagging.
- Inspect the seat and back for loose or broken hardware.
- Inspect the back cane hand grips for wear/looseness/deterioration.
- Inspect seat positioning strap for any signs of wear. Ensure buckle latches. Verify hardware that attaches strap to frame is secure and undamaged. Replace if necessary.
- Inspect tires for flat spots and wear.
- Check pneumatic tires for proper inflation.

---

### CAUTION

**As with any vehicle, check the wheels and tires periodically for cracks and wear. Replace if damaged.**

---

- If equipped, check that quick-release axles lock properly. Lubricate if necessary.
- Check that there is no excessive side movement or binding in the rear wheels when lifted and spun.
- Inspect rear wheels for cracked, bent or broken spokes.

- Ensure all spokes are uniformly tight.
- Inspect handrims for signs of rough edges or peeling.
- Inspect axle assembly for proper tension by spinning caster. Caster should come to a gradual stop.
- Adjust front casters/forks bearing system if wheel wobbles noticeably or binds to a stop.
- Ensure wheel bearings are clean and free of moisture.
- Check headtube locknuts for tightness.
- Inspect casters for cracks and wear.
- Inspect front casters for cracked, bent or broken spokes.
- Clean upholstery and armrests.

**Inspect/Adjust Weekly**

- Ensure that the wheel locks prevent the wheelchair from moving when engaged.
- Inspect tires for flat spots and wear.
- Check pneumatic tires for proper inflation.
- If equipped, check that quick-release axles lock properly. Lubricate if necessary.
- Inspect rear wheels for cracked, bent or broken spokes.
- Ensure all spokes are uniformly tight.
- Inspect axle assembly for proper tension by spinning caster. Caster should come to a gradual stop.
- Inspect front caster for cracked, bent or broken spokes.

**Inspect/Adjust Monthly**

- Ensure that the wheelchair rolls straight (no excessive drag or pull to one side).
- Check that the wheel locks DO NOT interfere with tires when rolling.
- Check that the wheel lock pivot points are free of wear and looseness.
- Inspect seat and back for loose or broken hardware.
- Inspect seat positioning strap for any signs of wear. Ensure buckle latches. Verify hardware that attaches strap to frame is secure and undamaged. Replace if necessary.
- Inspect back cane hand grips for wear/looseness/deterioration.
- Adjust front casters/forks bearing system if wheel wobbles noticeably or binds to a stop.
- Ensure wheel bearings are clean and free of moisture.
- Check headtube locknuts for tightness.

**Inspect/Adjust Periodically**

- Inspect frame and crossbraces for loose or missing hardware.
- Inspect for bent frame or crossbraces.
- Check that wheel locks are easy to engage.
- Inspect seat and backs for rips and sagging.
- Check that there is no excessive side movement or binding in the rear wheels when lifted and spun.
- Inspect handrims for signs of rough edges or peeling.
- Adjust front casters/forks bearing system if wheel wobbles noticeably or binds to a stop.
- Inspect casters for cracks and wear.
- Ensure that casters are free of debris.
- Ensure wheel bearings are clean and free of moisture.
- Clean upholstery and armrests.
- Check that all labels are present and legible. Replace if necessary.

**Troubleshooting**

Chair Veers Right/Left	Chair 3 Wheels	Sluggish Turn or Performance	Casters Flutter	Squeaks and Rattles	Looseness in Chair	Solutions
X	X	X	X			Check tires for correct and equal pressure
		X	X	X	X	Check for loose nuts and bolts.
X	X		X			Check caster headtube angle.
X	X					Check that rear wheels are equally spaced away from seat frame.

## Maintenance

### Maintenance Safety Precautions

---

#### **⚠ WARNING**

After any adjustments, repair or service and before use, make sure all attaching hardware is tightened securely. Otherwise injury or damage may result.

---

#### **CAUTION**

**DO NOT** overtighten hardware attaching to the frame. This could cause damage to the frame tubing.

---

### Suggested Maintenance Procedures

1. Before using your 9000 Series wheelchair, make sure all nuts and bolts are tight. Check all parts for damage or wear and replace. Check all parts for proper adjustment.
  2. 9000 SL/9000 XT ONLY - Keep quick-release axles free of dirt and lint to ensure positive locking and proper operation. Refer to [Adjusting Quick-Release Axle](#) on page 47.
  3. 9000 SL/9000 XT ONLY - Oil quick-release axles at least once a month (3-in-1 oil® or equivalent).
- 

#### **⚠ WARNING**

**DO NOT** use the wheelchair unless it has the proper tire pressure (p.s.i.). **DO NOT** overinflate the tires. Failure to follow these suggestions may cause the tire to explode and cause bodily harm.

---

4. If tires are pneumatic, recommended tire pressure is listed on the sidewall of the tire.
- 

#### **CAUTION**

**As with any vehicle, check the wheels and tires periodically for cracks and wear. Replace if damaged.**

---

5. The rear wheels, casters and tires should be checked periodically for cracks and wear, and should be replaced by a qualified technician if damaged.

*NOTE: Tire wear is excessive if:*

- Pneumatic Tires - there is missing tread or the tires are bald.
- Urethane Tires - there are cuts, surface defects or the tires are loose on the rims.
- Rubber Tires - 30% or more of the tire has worn away.

*NOTE: Invacare recommends that tires and casters be replaced every five years.*

6. Periodically adjust wheel locks in correlation to tire wear. Refer to [Adjusting Patient-Operated Wheel Locks](#) on page 53.
-

7. Periodically check handrims to ensure they are secured to the rear wheels. If loose, have them tightened by a qualified technician.
8. Periodically check caster wheel bearings to make sure they are clean and free from moisture. Use a Teflon<sup>®</sup> lubricant if necessary.

---

**⚠ WARNING**

**When cleaning rear cane or hand grip areas use only a clean towel lightly dampened with cool water. Verify that grips are dry prior to use. Use of soap or ammonia based cleaning solutions will result in the hand grips sliding off the cane assembly. Failure to observe this warning may result in injury to the user or bystanders.**

---

9. Hand grips should be checked monthly for wear/looseness/deterioration. Clean if desired. Replace if looseness or deterioration is found.
10. Check upholstery for sagging, rips or tears.
11. Replace any labels that are missing, worn, or torn. Refer to Label Locations on page 8 for a listing of labels and their locations.

# SECTION 4—FRONT RIGGINGS

## ⚠ WARNING

After any adjustments, repair or service and before use, make sure all attaching hardware is tightened securely. Otherwise injury or damage may occur.

## Installing/Removing Front Riggings

*NOTE: For this procedure, refer to FIGURE 4.1.*

### Installing

1. Turn the front rigging assembly to the side (open front rigging is perpendicular to wheelchair).
2. Install the hinge plates on the front rigging assembly onto the hinge pins on the wheelchair frame.
3. Push the front rigging assembly towards the inside of the wheelchair until it locks into place.

*NOTE: The footplate will be on the inside of the wheelchair when locked in place.*

4. Repeat this procedure for the other front rigging assembly.
5. To release the front rigging, push the front rigging release lever inward, rotate front rigging outward.

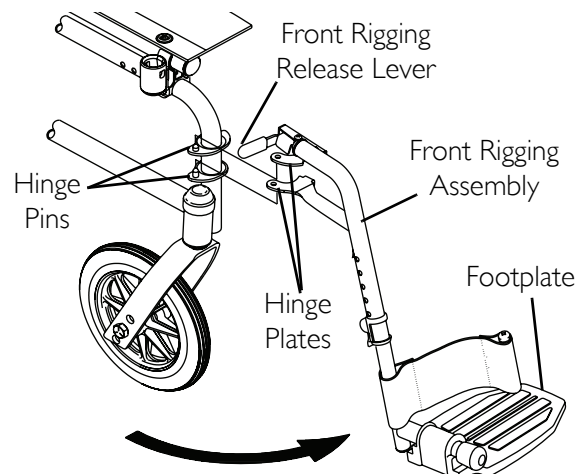

*NOTE: Swingaway footrest shown.*

**FIGURE 4.1** Installing/Removing Front Riggings

### Removing

1. Push the front rigging release lever inward
2. Rotate swingaway front rigging assembly outward.
3. Lift the swingaway front rigging assembly off the hinge pins.

## Adjusting Footplate Height

### Spring Button Height

*NOTE: For this procedure, refer to FIGURE 4.2.*

*NOTE: This procedure applies to the swingaway front riggings and swingaway elevating legrest.*

1. Remove the front rigging assembly. Refer to Installing/Removing Front Riggings on page 31.

*NOTE: Lay the front rigging assembly on a flat surface to simplify this procedure.*

2. Pull the cam lock lever up to unlocked position.

*NOTE: The elevating legrest has two sets of release buttons, one set above the other. Each set will be visible one at a time allowing finer footplate height adjustment.*

3. Push in the release buttons and reposition the footplate assembly to the desired height.
4. Ensure that the release buttons fully protrude from holes on both sides of the front rigging support.
5. Rotate cam lock lever down to locked position.
6. Repeat this procedure for the other footplate, if necessary.
7. Reinstall the swingaway front rigging assembly. Refer to Installing/Removing Front Riggings on page 31.

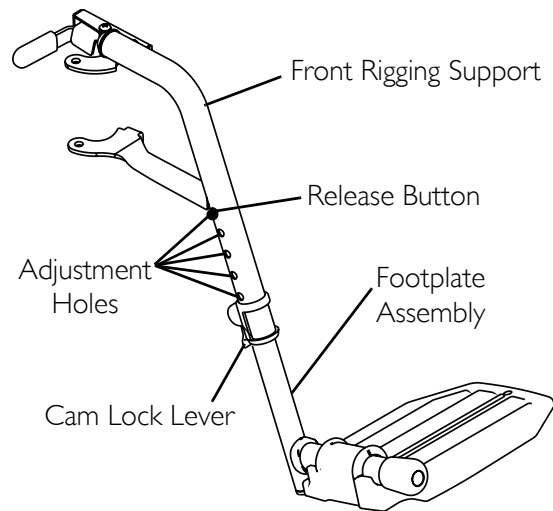

*NOTE: Swingaway footrest shown.*

**FIGURE 4.2** Spring Button Height

### Bolt-In-Place Height

*NOTE: For this procedure, refer to FIGURE 4.3 on page 33.*

*NOTE: This procedure applies to the swingaway footrests and swingaway elevating legrest.*

1. Remove the swingaway front rigging. Refer to Installing/Removing Front Riggings on page 31.

*NOTE: Lay the front rigging assembly on a flat surface to simplify this procedure.*

2. Pull the cam lock lever up to position.
3. Using a screw driver to hold the threaded rivet in position, remove the button head screw from the threaded rivet.
4. Remove the threaded rivet and button head screw securing the footplate assembly to the front rigging support.



5. Adjust the footplate assembly height by aligning the desired adjustment holes in the upper front rigging support and lower footplate assembly.
6. From the outside of the swingaway front rigging, insert the threaded rivet through both the front rigging support and the footplate assembly.
7. From the inside of the swingaway front rigging, insert the button head screw through the appropriate adjustment hole and thread into the threaded rivet.
8. Using a screwdriver to hold the threaded rivet in position, securely tighten the button head screw. Torque to 32 in-lbs.
9. Rotate cam lock lever down to locked position.
10. Repeat STEPS 1-9 to adjust the remaining footrest.

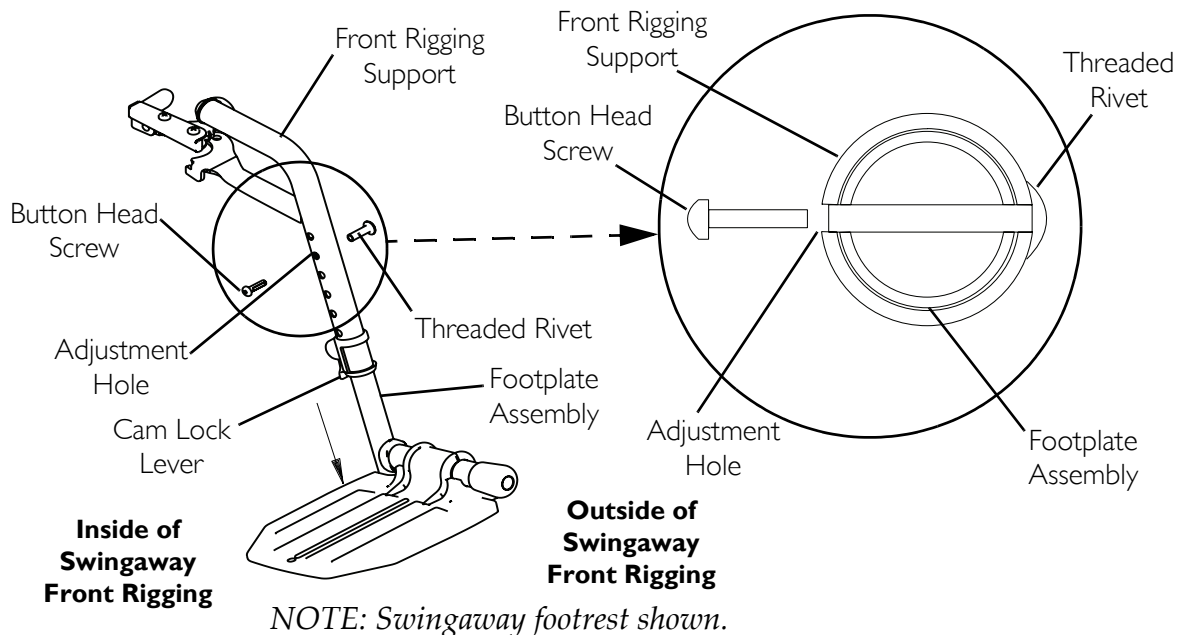

**FIGURE 4.3** Bolt-In-Place Height

## Raising/Lowering Elevating Legrest Assembly

### **⚠ WARNING**

Ensure hands and fingers are clear of elevating legrest mechanism before pushing release lever to lower the elevating legrest. Otherwise injury may occur due to pinch points.

The wheelchair user's leg **MUST** be supported by an assistant before attempting to lower legrest.

*NOTE: For this procedure, refer to FIGURE 4.4 on page 34.*

1. To raise the elevating legrest, the assistant should hold the support tube and raise the elevating legrest until the desired height is obtained.
2. To lower the elevating legrest, perform the following:
  - A. Support user leg with one hand.
  - B. Push release lever downward with other hand.
  - C. Gently, lower user leg down and rest against the legrest.

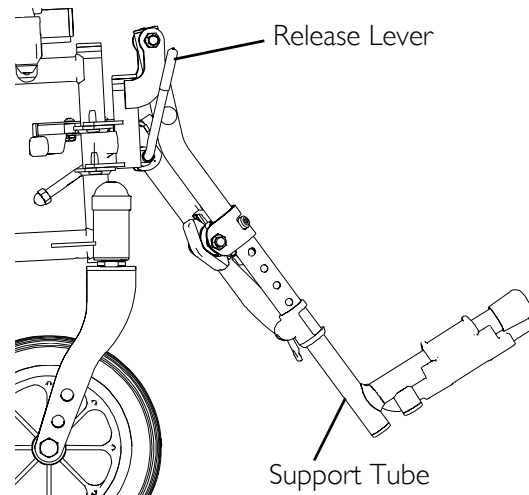

**FIGURE 4.4** Raising/Lowering Elevating Legrest Assembly

## Installing Impact Guards/Calf Strap

*NOTE: For this procedure, refer to FIGURE 4.5.*

1. Remove impact guard/calf strap from packaged container if not already secured to the footrest.
2. Secure one impact guard to the each footrest.

*NOTE: Ensure the upper portion of the impact guard is between the two horizontal supports of the footrest.*

3. Secure one side of the calf strap around each footrest (with the impact guards attached, if present).

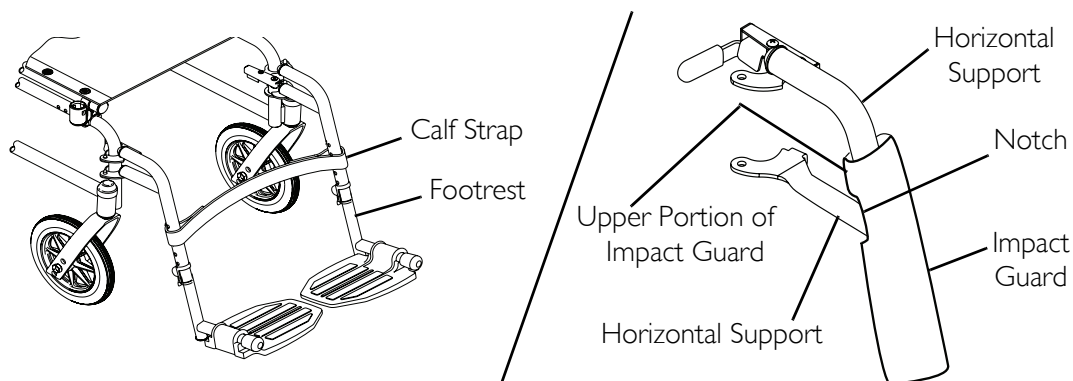

**FIGURE 4.5** Installing Impact Guards/Calf Strap

## Replacing Heel Loop

*NOTE: For this procedure, refer to FIGURE 4.6 on page 36.*

1. Pull the cam lock lever up to unlocked position.
2. Perform one of the following as shown in Detail “A”.
  - Footplates with Spring Buttons: Push in the release buttons and remove the footplate assembly from the front rigging support.
  - Bolt-In-Place Footplates:
    - i. Using a screw driver to hold the threaded rivet in position, remove the button head screw from the threaded rivet.
    - ii. Remove the threaded rivet and button head screw securing the footplate assembly to the front rigging support.
3. Remove the mounting screw, spacer and locknut that secure the heel loop to the footplate.
4. Remove existing heel loop from slide tube.
5. Install new heel loop onto slide tube.
6. Install the mounting screw, spacer and locknut to secure the heel loop to the footplate. Tighten until the spacer is secure.
7. Insert the lower footrest assembly into the upper footrest assembly to desired height.
8. Perform one of the following as shown in Detail “A”:
  - Footplates With Spring Buttons: Ensure that the release buttons fully protrude from holes on both sides of the upper footrest support.
  - Bolt-In-Place Footplates:
    - i. From the outside of the swingaway front rigging, insert the threaded rivet through both the front rigging support and the footplate assembly.
    - ii. From the inside of the swingaway front rigging, insert the button head screw through the appropriate adjustment hole and thread into the threaded rivet.
    - iii. Using a screwdriver to hold the threaded rivet in position, securely tighten the button head screw. Torque to 32 in-lbs.
9. Rotate cam lock lever down to locked position.

**DETAIL "A"**

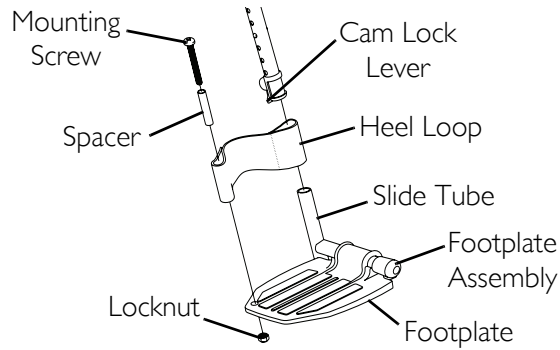
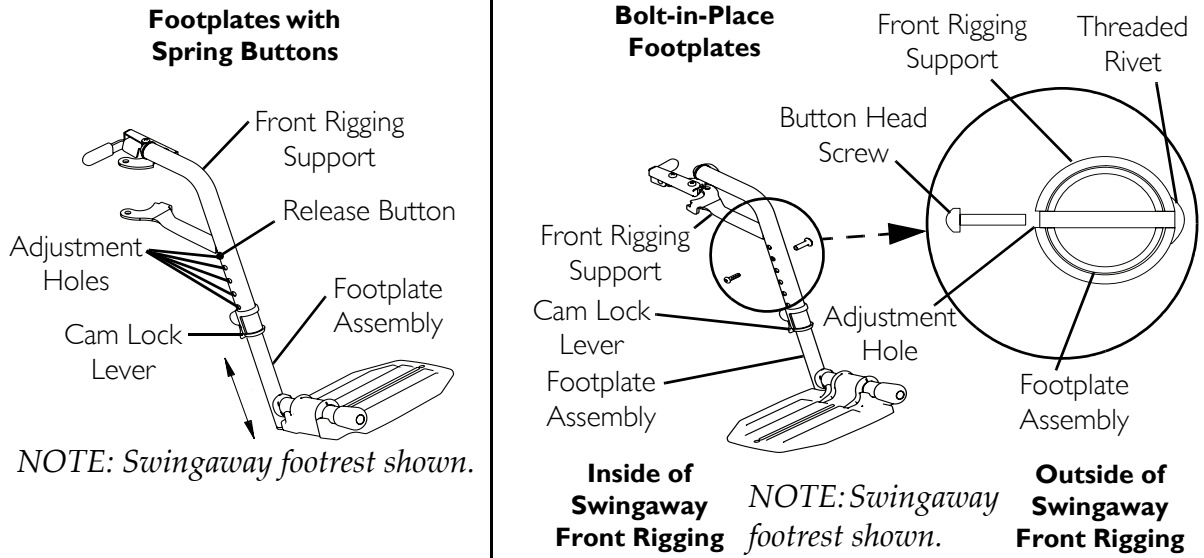

**FIGURE 4.6** Replacing Heel Loop

## SECTION 5—ARMS

### ⚠ WARNING

After any adjustments, repair or service and before use, make sure all attaching hardware is tightened securely. Otherwise injury or damage may occur.

## Adjusting Armrest Height

### ⚠ WARNING

Make sure the height adjustment lever is in the locked position before using the wheelchair.

NOTE: For this procedure, refer to FIGURE 5.1.

1. Unlock the armrest by flipping the height adjustment lever on the top front of the armrest to the up (horizontal) position.

2. Adjust armrest to one of five positions.

NOTE: Height adjustment lever MUST be in the unlocked position when placing armrest into the arm assembly.

3. Lock the armrest by pressing the height adjustment lever into the down (vertical) position when the desired armrest height is achieved.
4. Repeat STEPS 1-3 for other armrest.

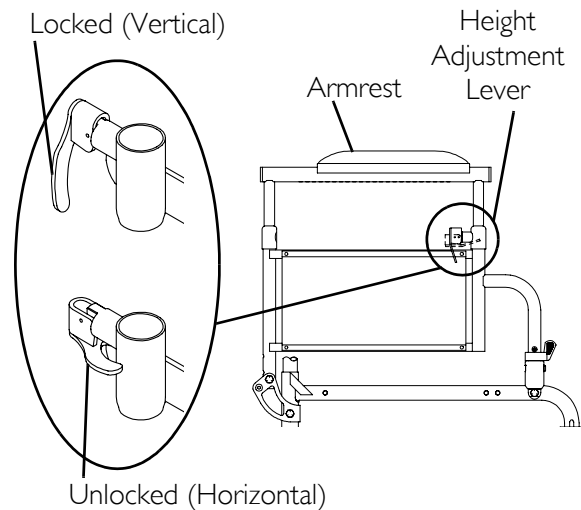

FIGURE 5.1 Adjusting Armrest Height

## Using Swing-Back Arms

### ⚠ WARNING

Make sure the armrest release lever is in the locked position before using the wheelchair.

NOTE: For this procedure, refer to FIGURE 5.2 on page 38.

NOTE: This procedure applies to 9000SL, 9000XT, and 9000XDT wheelchairs only.

1. Unlock the swing-back arms by rotating the armrest release lever toward the outside of the wheelchair.

2. Pull the front of the swing-back arm straight up/out of the arm socket and towards the rear of the wheelchair.
3. To use the swing-back arm, push the swing-back arm towards the front of the wheelchair and then downward into the arm socket.

*NOTE: Armrest release lever MUST be in the unlocked position when placing armrest into the arm sockets.*

4. Lock the swing-back arms by rotating the armrest release lever towards the inside of the wheelchair.

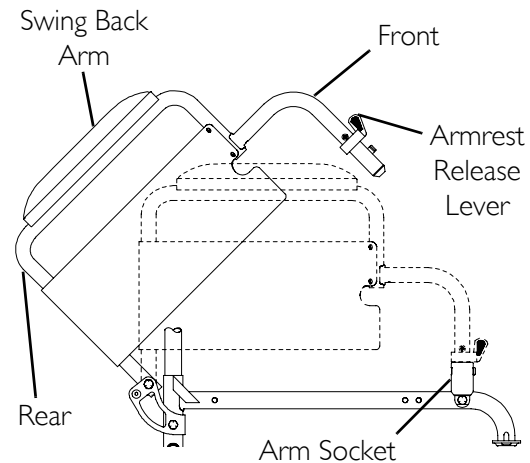

**FIGURE 5.2** Using Swing-Back Arms

## Removing or Replacing Armrest

### ⚠ WARNING

**Make sure the armrest release lever is in the locked position before using the wheelchair.**

**9000XDT: Use only heavy duty, fixed height armrests on 9000XDT wheelchairs. Otherwise injury or damage may occur.**

*NOTE: For this procedure, refer to FIGURE 5.3.*

*NOTE: This procedure does not apply to 9000 SL wheelchairs equipped with space saver arms.*

### Removing Armrests

1. Unlock the armrest by turning the armrest release levers towards the outside of the wheelchair.
2. Lift armrest completely out of arm sockets from the wheelchair.

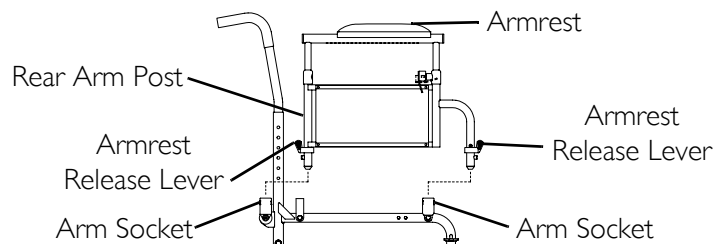

**FIGURE 5.3** Removing or Replacing Armrest

## Replacing Armrests

*NOTE: Armrest release levers MUST be in the unlocked position when placing armrest into the arm sockets.*

1. Place armrest into arm sockets located on the side of the wheelchair.
2. Lock the armrest by turning the armrest release levers towards the inside of the wheelchair.

## Replacing Desk/Full Length Armrest Pad (Fixed Height Arms Only)

*NOTE: For this procedure, refer to FIGURE 5.4.*

1. Remove the mounting screws that secure the armrest pad to the armrest assembly.
2. Replace armrest pad and securely tighten with the existing mounting screws.

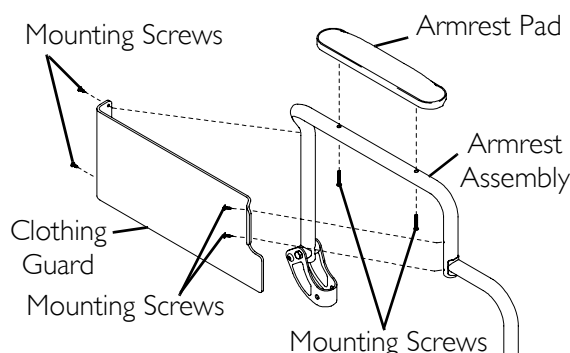

**FIGURE 5.4** Replacing Desk/Full Length Armrest Pad (Fixed Height Arms Only)

## Replacing Clothing Guards (Fixed Height Arms Only)

*NOTE: For this procedure, refer to FIGURE 5.4.*

1. Remove the four mounting screws that secure the existing clothing guard to the armrest assembly.
2. Install new clothing guard and securely tighten with the existing mounting screws.

## Converting Between Space Saver and Conventional Arms

*NOTE: For this procedure, refer to FIGURE 5.5 on page 40.*

*NOTE: Space Saver arms DO NOT work with the following:*

- 9000XT/9000SL with the adjustable angle back option.
- 9000XT Recliner.

1. Remove the arms from the wheelchair. Refer to [Removing or Replacing Armrest](#) on page 38.
2. Remove the locknut and hex screw that secure the arm socket to the wheelchair frame.
3. Repeat STEP 2 for the opposite side of the wheelchair.

4. Reposition the arm socket to one of two positions:

ARM TYPE	ARM SOCKET POSITION (ON WHEELCHAIR FRAME)
<b>CONVENTIONAL SPACE SAVER</b>	Outside Inside

*NOTE: Make sure arm sockets sit flush against the wheelchair frame.*

5. Reinstall the hex screw and locknut that secure the arm socket to the wheelchair frame and securely tighten.
6. Repeat STEP 5 for the opposite side of the wheelchair.
7. Install the new arms onto the wheelchair. Refer to [Removing or Replacing Armrest](#) on page 38.
8. Refer to the following chart to determine if the rear wheel axle spacer is needed:

ARM TYPE	AXLE SPACER NEEDED?
<b>CONVENTIONAL SPACE SAVER</b>	Yes No

9. If rear wheel axle spacer is needed, refer to [Removing/Installing Rear Wheels](#) on page 44.

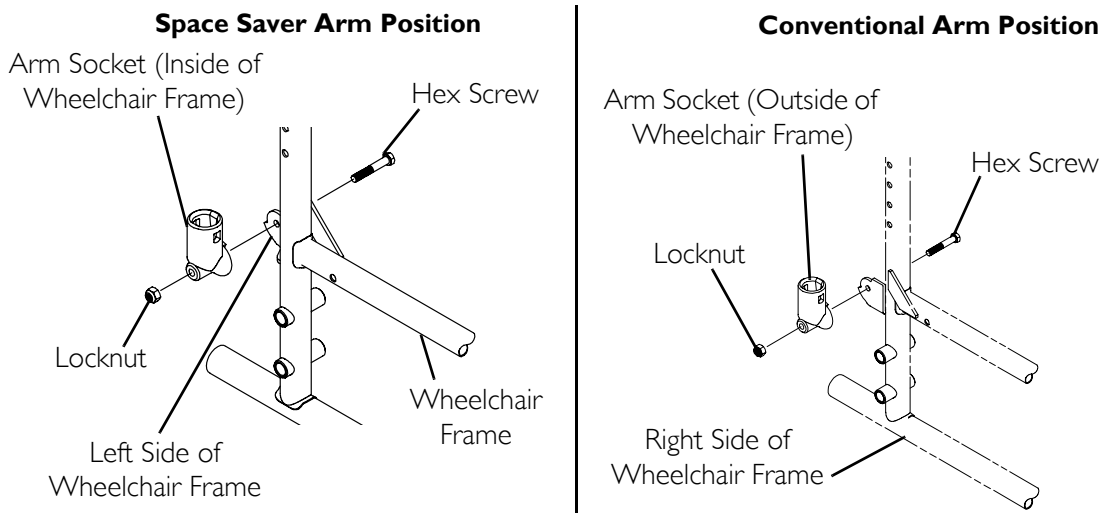

**FIGURE 5.5** Converting Between Space Saver and Conventional Arms



# SECTION 6—SEAT AND BACK

### ⚠ WARNING

After any adjustments, repair or service and before use, make sure all attaching hardware is tightened securely. Otherwise injury or damage may occur.

NOTE: The procedures in this section apply to non-recliner models only. For 9000XT recliner models, refer to Recliner on page 56.

## Replacing Seat Upholstery

NOTE: For this procedure, refer to FIGURE 6.1.

1. Remove the mounting screws that secure the existing seat upholstery to the wheelchair frame.

NOTE: The following chart determines the number of mounting screws for each seat depth.

SEAT DEPTH	NUMBER OF SCREWS
16-INCH	8
17-INCH TO 20-INCH	10

2. Remove the existing seat upholstery from the wheelchair frame.
3. Install new seat upholstery by reversing STEPS 1-2.

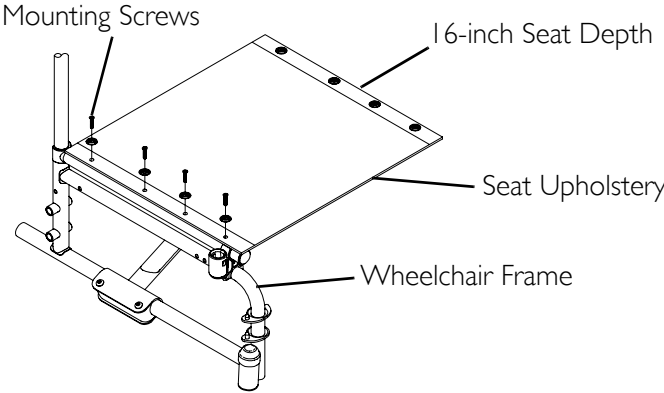

FIGURE 6.1 Replacing Seat Upholstery

## Replacing Back Upholstery

### Screw-On Back Upholstery

NOTE: For this procedure, refer to FIGURE 6.2 on page 42.

NOTE: This procedure applies to 9000 SL without adjustable back angle option.

1. Flip swing-back arms up and out of the way. Refer to [Using Swing-Back Arms](#) on page 37.
2. Remove the six mounting screws and washers that secure the existing back upholstery to the back canes.
3. Cut the tie wraps that secure the existing back upholstery to the wheelchair frame.
4. Securely tighten the new back upholstery to the back canes with the six mounting screws and washers starting with the top hole of the back cane.
5. Install two new tie wraps through the bottom holes of the upholstery to tie the bottom of the back upholstery to the back canes.
6. Flip swing-back arms down for use. Refer to [Using Swing-Back Arms](#) on page 37.

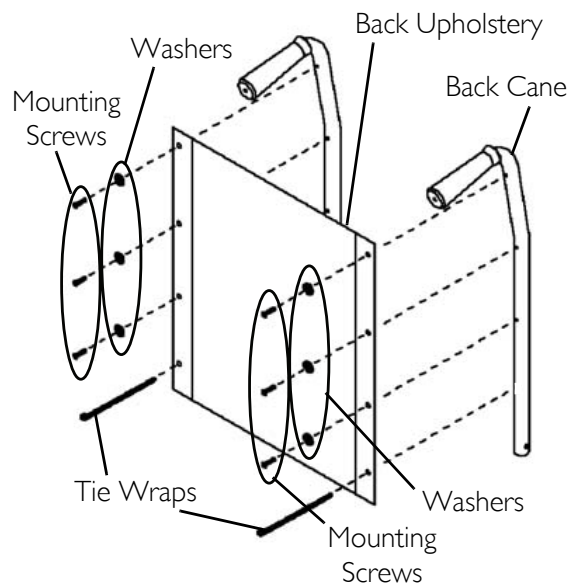

**FIGURE 6.2** Replacing Back Upholstery - Screw-On Back Upholstery

### Slip-On Back Upholstery

*NOTE: For this procedure, refer to FIGURE 6.3 on page 43.*

*NOTE: This procedure applies to 9000 XT/XDT and 9000 SL with adjustable back angle option.*

1. Remove the two mounting screws and washers that secure the existing back upholstery to the back canes (Detail "A").
2. Remove the two mounting screws, spacers and locknuts that secure one back cane to the wheelchair frame (Detail "B").

*NOTE: It is necessary to remove only one back cane to replace the back upholstery.*

3. Pull the loose back cane out of the existing back upholstery.
4. Pull the existing back upholstery up and over the mounted back cane.
5. Install the new back upholstery over the mounted back cane.
6. Slide the loose back cane through the new back upholstery.
7. Secure the back cane to the wheelchair frame with the two mounting screws, spacers and locknuts.

*NOTE: The spacers MUST be on the outside of the wheelchair in order to properly tighten the mounting screws.*

8. Secure the new back upholstery to the back canes with the existing mounting screws and washers.

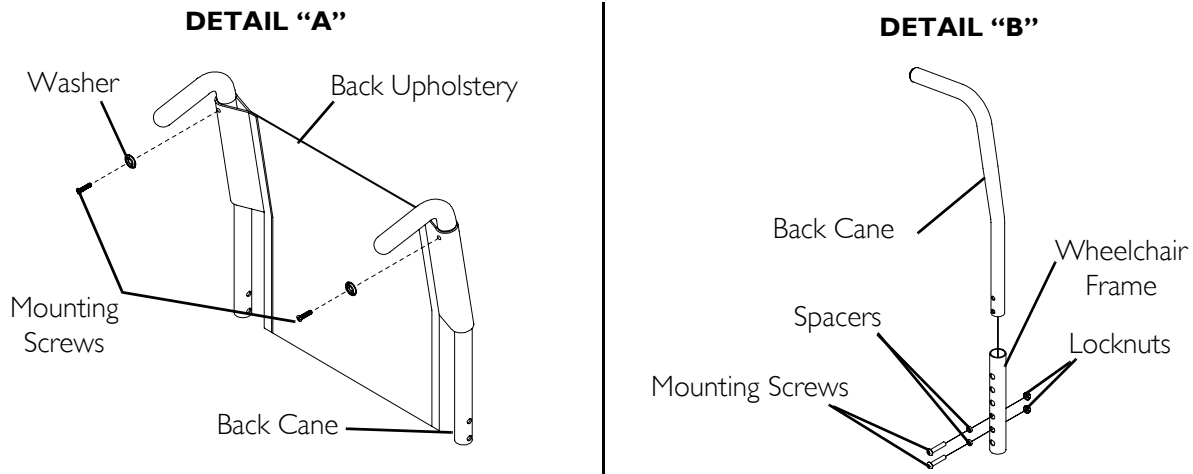

**FIGURE 6.3** Replacing Back Upholstery - Slip-On Back Upholstery

## Adjusting Back Height, Back Angle or Seat Depth

### ⚠ WARNING

The seat depth, back height/angle, seat angle, size/position of the front casters, size/position of the rear wheels, anti-tipper model, as well as the user condition directly relate to the stability of the wheelchair. Any change to one or any combination of the ten may cause the wheelchair to decrease in stability. These adjustments **MUST** be performed by a qualified technician.

## Adjusting Seat Width

### ⚠ WARNING

Adjusting the seat width of the 9000SL, 9000XT, 9000XDT **MUST** be performed by a qualified technician.

## SECTION 7—REAR WHEELS

---

### **⚠ WARNING**

**After any adjustments, repair or service and before use, make sure all attaching hardware is tightened securely. Otherwise injury or damage may occur.**

---

*NOTE: Except where noted, the procedures in this section apply to non-recliner models only. For recliner models, refer to Recliner on page 56.*

## Removing/Installing Rear Wheels

---

### **⚠ WARNING**

**Only a qualified technician may change the size of the rear wheel or the seat-to-floor height.**

---

### Permanent Axles

---

### **⚠ WARNING**

**If the wheelchair is equipped with permanent axles, removal/installation of the rear wheels **MUST** be performed by a qualified technician.**

---

### Quick-Release Axles

---

### **⚠ WARNING**

**NEVER use quick-release axles on the 9000 XT (models with offset axle option only), 9000XDT or 9000XT recliner wheelchairs.**

---

*NOTE: For this procedure, refer to FIGURE 7.1 on page 45.*

*NOTE: If replacing the same size rear wheel, note the mounting position on the wheelchair frame for proper reinstallation of the new rear wheel.*

1. Push in the detent pin of the quick-release axle (with wheel) and pull the axle out through the opening in the center of the rear wheel and axle spacer.

*NOTE: Axle spacer is used only if wheelchair is equipped with conventional arms.*

2. Push in the detent pin of the quick-release axle again and pull the axle out of the rear wheel.
3. Repeat STEPS 1-2 for the opposite rear wheel.
4. To reinstall the rear wheel onto the wheelchair, reverse STEPS 1-3.

*NOTE: Make sure axle spacer is between rear wheel and wheelchair frame if wheelchair is equipped with conventional arms.*

---

## ⚠ WARNING

**Make sure the detent pin and detent balls of the quick-release axle are fully released before operating the wheelchair.**

**The detent balls **MUST** be protruding past the inside of the rear wheel axle bushing for a positive lock (Detail "A").**

**Keep detent balls clean.**

**Invacare recommends inserting quick-release axles with the detent pin to the inside of the wheelchair to prevent accidental release during contact activities.**

5. If the detent balls are not protruding past the inside of the axle bushing or there is too much side-to-side movement of the rear wheel assembly, refer to Adjusting Quick-Release Axle on page 47.

### DETAIL "A" - DETENT BALLS AND DETENT PIN

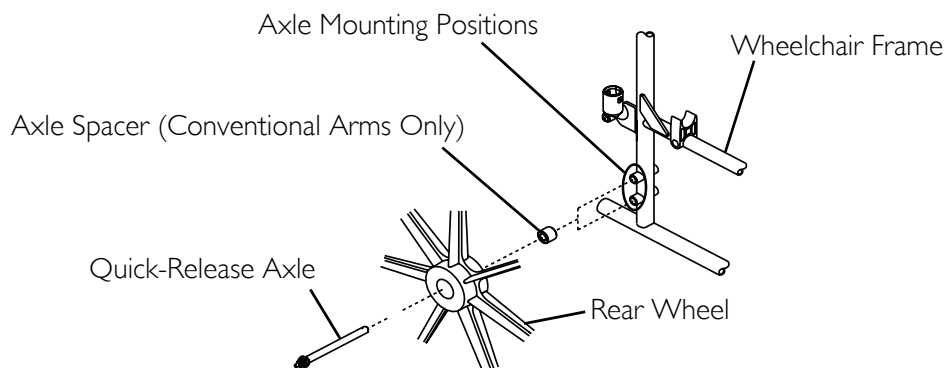
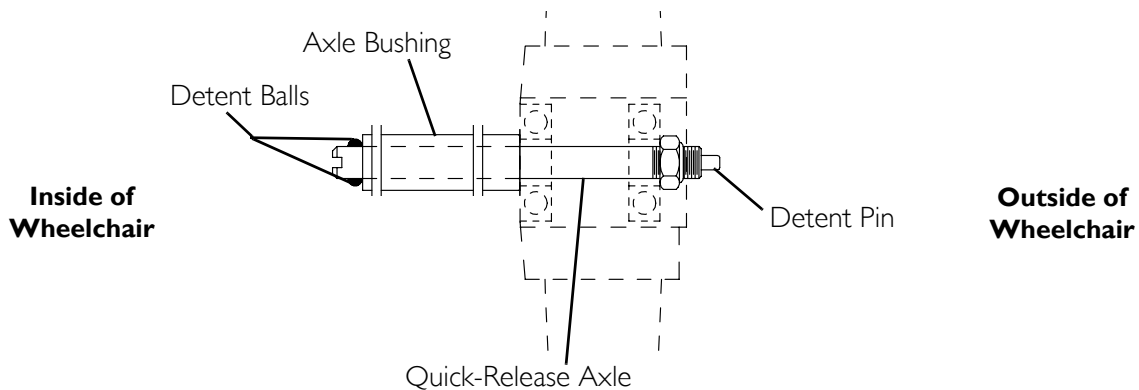

**FIGURE 7.1** Removing/Installing Rear Wheels - Quick-Release Axles

## Replacing Rear Wheel Handrim

### ⚠ WARNING

Wheelchairs with 300lbs weight limit: **DO NOT** use composite handrims. Otherwise injury or damage may occur.

If the wheelchair is equipped with permanent axles, this procedure **MUST** be performed by a qualified technician.

*NOTE: For this procedure, refer to FIGURE 7.2.*

1. Remove the rear wheel from the wheelchair. For non-recliner models, refer to [Removing/Installing Rear Wheels](#) on page 44. For 9000XT Recliner, refer to [Removing/Installing Rear Wheels](#) on page 61.
2. Remove the mounting screws that secure the handrim to the rear wheel.
3. Remove the existing handrim.
4. Install the new handrim by reversing the preceding steps.

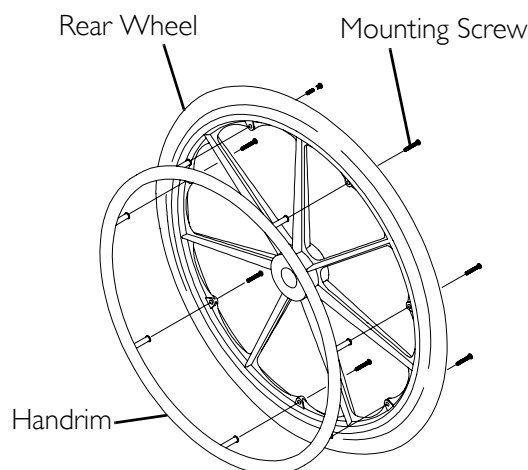

**FIGURE 7.2** Replacing Rear Wheel Handrim

### ⚠ WARNING

**Make sure detent pin and detent balls of the quick-release axles are fully released before operating the wheelchair.**

5. Reinstall rear wheel to the wheelchair. Refer to [Removing/Installing Rear Wheels](#) on page 44.
6. If the detent balls of the quick-release axles (if applicable) are not protruding past the inside of the axle bushing or there is too much movement of the rear wheel assembly in a back and forth position, refer to [Adjusting Quick-Release Axle](#) on page 47.
7. Repeat STEPS 1-6 for the opposite rear wheel if necessary.

## Replacing/Repairing Rear Wheel Tire/Tube

### ⚠ WARNING

Replacement of rear wheel tire or tube **MUST** be performed by a qualified technician.

## Adjusting Quick-Release Axle

### **⚠ WARNING**

**NEVER** use quick-release axles on the 9000 XT (models with offset axle option only), 9000XDT or 9000XT recliner wheelchairs.

*NOTE:* For this procedure, refer to FIGURE 7.3.

1. Remove rear wheel and quick-release axle from the wheelchair. Refer to [Removing/Installing Rear Wheels](#) on page 44.
2. Depress detent pin in the quick-release axle and slide axle through the rear wheel hub.
3. Release detent pin ensuring that the detent balls are fully released.
4. Increase or decrease end play by adjusting the locknut on the end of the quick-release axle.

### **⚠ WARNING**

**Make sure detent pin and detent balls of the quick-release axles are fully released before operating the wheelchair.**

**Keep detent balls clean.**

5. Reinstall rear wheel onto the wheelchair. Refer to [Removing/Installing Rear Wheels](#) on page 44.

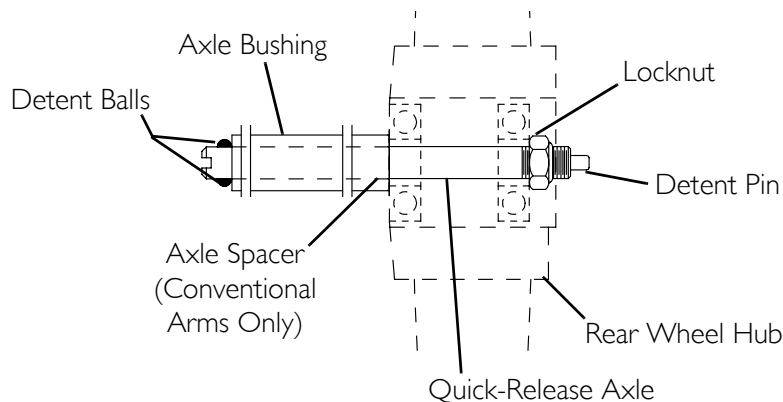

**FIGURE 7.3** Adjusting Quick-Release Axle

## SECTION 8—FRONT CASTERS

---

### **⚠ WARNING**

After any adjustments, repair or service and before use, make sure all attaching hardware is tightened securely. Otherwise injury or damage may occur.

---

## Installing/Replacing Six or Eight-Inch Front Casters and Forks

---

### **⚠ WARNING**

If converting from a six-inch caster to an eight-inch caster or vice versa, there are seat-to-floor height adjustments that **MUST** be made. Therefore, this procedure **MUST** be performed by a qualified technician.

---

*NOTE: For this procedure, refer to FIGURE 8.1 on page 49.*

*NOTE: This procedure can be performed if replacing the exact same size front caster.*

1. Remove the dust cover.
2. Remove the locknut that secures the fork to the caster headtube.
3. Drop the front caster and fork out of the caster headtube.

*NOTE: 9000XDT ONLY - Make sure to reinstall the 2-inch extension spacer. See Detail "A".*

4. Slide in the new six/eight-inch front caster and fork.
5. Reassemble by reversing STEPS 1-3.
6. Repeat STEPS 1-5 for the opposite front caster.
7. To properly tighten caster journal system and guard against flutter, perform the following check:
  - A. Tip back of wheelchair to floor.
  - B. Pivot both forks and casters to top of their arc simultaneously.
  - C. Let casters drop to bottom of arc (wheels should swing once to one-side, then IMMEDIATELY rest in a straight downward position).
  - D. Adjust locknuts according to freedom of caster swing.
8. Test wheelchair for maneuverability.
9. Readjust locknuts if necessary, and repeat STEPS 7-8 until correct.
10. Snap dust cover over the locknut and stem.



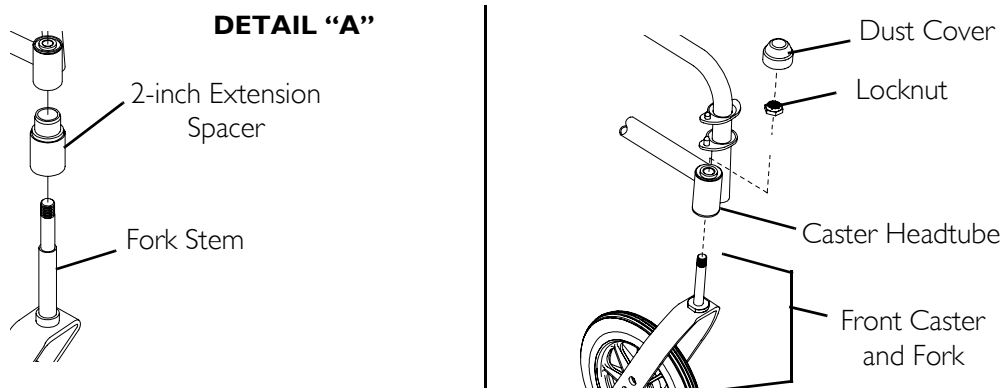

**FIGURE 8.1** Installing/Replacing Six or Eight-Inch Front Casters and Forks

## Replacing/Repairing Front Caster Tire/Tube

### **⚠ WARNING**

Replacement of front caster tire or tube **MUST** be performed by a qualified technician.

### **CAUTION**

As with any vehicle, check the wheels and tires periodically for cracks and wear. Replace if damaged.

## Adjusting Front Caster Mounting

### **⚠ WARNING**

Front caster mounting adjustments **MUST** be performed by a qualified technician.

# SECTION 9—ANTI-TIPPERS/WHEEL LOCKS

---

## **⚠ WARNING**

**After any adjustments, repair or service and before use, make sure all attaching hardware is tightened securely. Otherwise injury or damage may occur.**

---

*NOTE: The procedures in this section apply to non-recliner models only except where noted. For the 9000XT recliner, refer to Recliner on page 56.*

## Installing/Adjusting Anti-tippers

---

### **⚠ WARNING**

**Anti-tippers are specific to the different seat-to-floor angles and/or seat-to-floor heights. Refer to the chart in this section of the manual for correct usage and adjustment. If these requirements cannot be achieved, DO NOT use the wheelchair. Contact a qualified technician. If changing the seat-to-floor height with or without a change to seat-to-floor angle, the correct anti-tippers MUST be used to maintain a 1-1/2 to 2-inch ground clearance.**

**Seat-to-floor angle of 0° or 3°: If so equipped, anti-tippers MUST be attached at all times. Inasmuch as the anti-tippers are an option for 0° or 3° on this wheelchair (you may order with or without the anti-tippers), Invacare strongly recommends ordering the anti-tippers as a safeguard for the wheelchair user.**

**Seat-to-floor angle of 6°: If changing the seat-to-floor angle to 6°, anti-tippers MUST be ordered and installed.**

**Anti-tippers MUST be fully engaged and release buttons fully protruding out of adjustment holes.**

**ALWAYS use anti-tippers. When outdoors on wet, soft ground or on gravel surfaces, anti tippers may not provide the same level of protection against tipover. Extra caution MUST be observed when traversing such surfaces.**

**Ensure both anti-tippers are adjusted to the same mounting hole.**

---

## Installing Anti-Tippers

*NOTE: For this procedure, refer to FIGURE 9.1 on page 51.*

1. Remove plug button (not shown) from end of rear frame tubing and install anti-rattles if not already installed.
2. Press the release buttons in and insert the anti-tippers with the anti-tipper wheels pointing toward the ground/floor into the rear frame tubing until the bottom release button locks in place.

3. Measure the distance between the bottom of the anti-tipper wheels and the ground/floor.

*NOTE: A 1½ to 2-inch clearance between the bottom of the anti-tipper wheels and the ground/floor MUST be maintained at all times.*

4. If the distance between the bottom of anti-tipper wheels and the ground/floor is not 1½ to 2-inches, adjust anti-tippers. Refer to [Adjusting Anti-Tippers](#) on page 51.

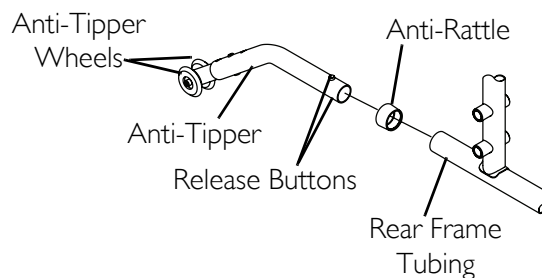
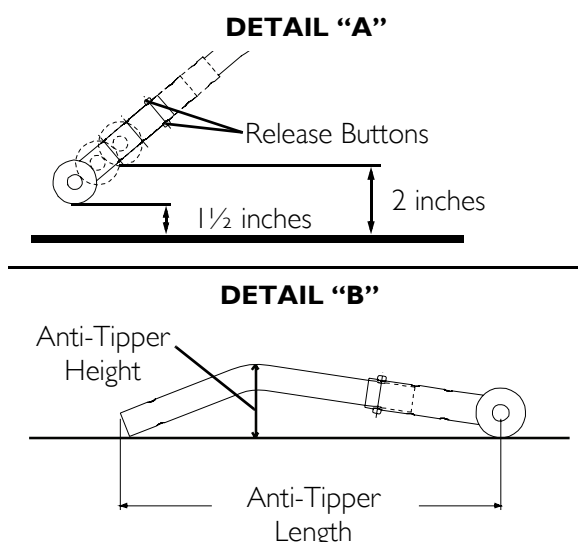

**FIGURE 9.1** Installing Anti-Tippers

## Adjusting Anti-Tippers

*NOTE: For this procedure, refer to FIGURE 9.2.*

1. Press the release buttons on the wheeled portion of the anti-tipper and slide it up or down to achieve the 1-1/2 to 2-inch clearance (Detail "A").
2. Check to make sure that the release buttons are fully engaged in adjustment holes.



**FIGURE 9.2** Adjusting Anti-Tippers

*NOTE: Refer to Detail "B" in FIGURE 9.2 and to the following charts to ensure the correct anti-tipper is installed in the wheelchair. Seat-to-Floor heights are approximate depending on front caster size and type. Anti-Tipper length measurement is taken with the extension tube in the longest position available. The anti-tipper height measurement MUST be taken with the anti-tipper on a flat surface.*

9000 XT (SUPER LOW FRAME)				
CASTER SIZE	SEAT-TO-FLOOR HEIGHT	ANTI-TIPPER LENGTH/HEIGHT	ON CHAIR	OFF CHAIR KIT NUMBER
6-inch	13½ and 14½ inches	10½ / 2-inches	I360SH	1064520
9000 XDT (ADULT TALL FRAME)				
CASTER SIZE	SEAT-TO-FLOOR HEIGHT	ANTI-TIPPER LENGTH/HEIGHT	ON CHAIR	OFF CHAIR KIT NUMBER
8-inch	17½ and 19½ inches	11-5/8 / 2-3/4-inches	I360A	1058752
8-inch	21½-inches	13½ / 3½-inches	I360	1058836

9000 XT WITH 0° SEAT-TO-FLOOR ANGLE (ADULT/HEMI FRAME)				
CASTER SIZE	SEAT-TO-FLOOR HEIGHT	ANTI-TIPPER LENGTH/HEIGHT	ON CHAIR	OFF CHAIR KIT NUMBER
8-inch	17½, 18½ inches	13½ / 3½-inches	N/A	1058836
6-inch	16½, 17½-inches	13½ / 3½-inches	N/A	1058366
	15½-inches	11-5/8 / 2-3/4-inches	N/A	1058752

9000 XT WITH 3° SEAT-TO-FLOOR ANGLE AND 9000 SL (ADULT/HEMI FRAMES)				
CASTER SIZE	SEAT-TO-FLOOR HEIGHT	ANTI-TIPPER LENGTH/HEIGHT	ON CHAIR	OFF CHAIR KIT NUMBER
8-inch	17½, 18½, 19½-inches	13½ / 3½-inches	1360	1058836
6-inch	15½, 16½, 17½-inches	11-5/8 / 2¾-inches	1360A	1058752

9000 XT WITH 6° SEAT-TO-FLOOR ANGLE (ADULT/HEMI FRAME)				
CASTER SIZE	SEAT-TO-FLOOR HEIGHT	ANTI-TIPPER LENGTH/HEIGHT	ON CHAIR	OFF CHAIR KIT NUMBER
8-inch	17½, 18½, 19½-inches	13½ / 2-7/8-inches	N/A	1113766
6-inch	16½, 17½-inches	12½ / 2¾-inches	N/A	1113765
	15½-inches	9½ / 2-3/8-inches	N/A	1113764

## Using/Adjusting Disk Wheel Locks

### Using Patient Operated Disk Wheel Locks

#### **⚠ WARNING**

**DO NOT attempt to stop a moving wheelchair with wheel locks. Wheel locks are not brakes.**

*NOTE: For this procedure, refer to FIGURE 9.3 on page 53.*

*NOTE: Position wheelchair on a flat, level surface to perform this procedure.*

1. Ensure the wheelchair is not moving before engaging the wheel locks.
2. Depending on the model of wheel lock installed on the wheelchair, perform one of the following:
  - Push-to-Lock - To engage, push the wheel lock handle forward.
  - Pull-to-Lock - To engage, pull the wheel lock handle backward.
3. Disengage the wheel locks by reversing STEP 2.

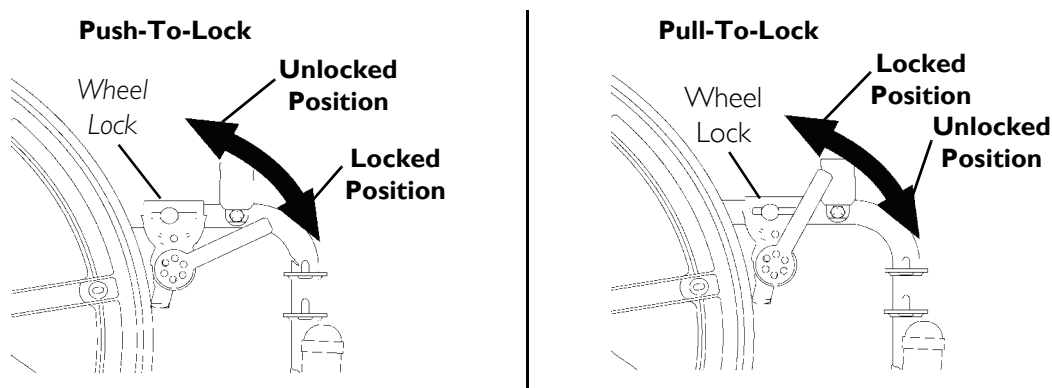

**FIGURE 9.3** Using Patient Operated Disk Wheel Locks

### Adjusting Patient-Operated Wheel Locks

*NOTE: For this procedure, refer to FIGURE 9.4 on page 54.*

*NOTE: The push-or-pull-to-lock wheel locks are also an option on the 9000XT Recliner.*

*NOTE: If wheels are pneumatic, before adjusting or replacing the wheel lock assemblies, ensure that the tires are inflated to the recommended psi on the side wall of tire. The recommended tire pressure is located on the side wall of the tire.*

1. Disengage the wheel locks.
2. Perform one of the following:
  - Bolt-on Wheel locks - Loosen the bolt and locknut that secure the wheel lock to the wheelchair frame.
  - Clamp-on wheel locks - Loosen the two socket screws that secure the wheel lock to the wheelchair frame.
3. Reposition the wheel lock so that when engaged, the wheel lock shoe embeds the tire 1/8-inch (3/16-inch for pneumatic tires) and holds the occupied wheelchair in place when pushed.
4. Securely tighten the bolt and locknut or socket screws securing the wheel lock to the wheelchair frame.
5. Engage the wheel lock.
6. Measure the distance the wheel lock is embedded into the tire as shown in FIGURE 9.4 on page 54.

*NOTE: Any wheel lock adjustment should embed the wheel lock shoe at least 1/8-inch (3/16-inch if pneumatic tire) into the tire when engaged.*

7. Repeat STEPS 1-6 until the wheel lock shoe embeds the tire 1/8-inch (3/16-inch for pneumatic tires) and holds the occupied wheelchair in place when pushed.

8. If the measurement of 1/8-inch (3/16-inch for pneumatic tires) can not be achieved, Perform one of the following:
  - Bolt-on wheel locks - Remove the bolt and locknut that secure the wheel lock to the wheelchair frame and mount the wheel lock in the remaining mounting position.
  - Clamp-on Wheel locks - Proceed to STEP 9.
9. If wheel lock is unable to properly engage the wheel it may be necessary to install wheel lock shoe extensions. Refer to [Installing Wheel Lock Shoe Extensions](#) on page 55.
10. Repeat STEPS 1-9 for the opposite wheel lock.
11. Engage both wheel locks and ensure the occupied wheelchair is held in place when pushed.

**⚠ WARNING**

**If wheel locks DO NOT hold the occupied wheelchair in place, contact a qualified technician. Otherwise injury or damage may occur.**

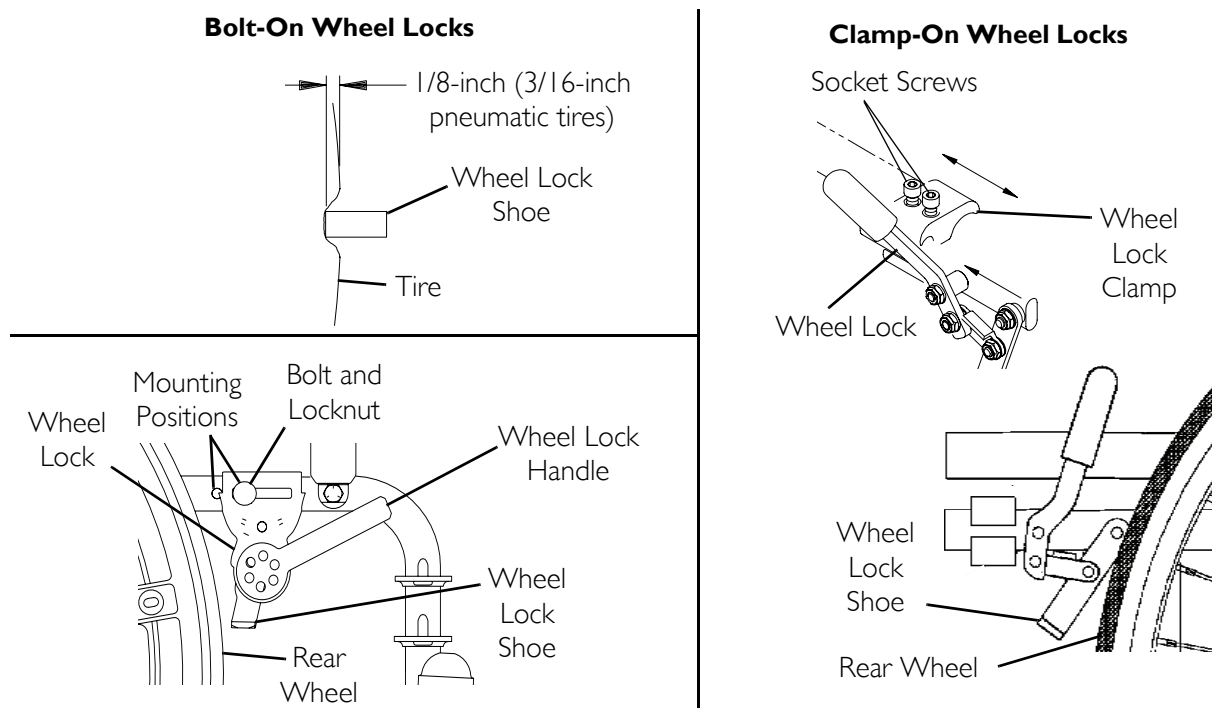

**FIGURE 9.4** Adjusting Patient-Operated Wheel Locks

## Installing Wheel Lock Shoe Extensions

*NOTE: For this procedure, refer to FIGURE 9.5.*

1. Loosen the two set screws on the wheel lock shoe extension until the set screws DO NOT protrude into the slot.
2. Insert the disk wheel lock shoe into the slot in the shoe extension.

*NOTE: Ensure the pointed end of the wheel lock shoe extension is facing toward the rear wheel.*

3. Position the wheel lock shoe extension so the outside edge is flush with the outside edge of the wheel lock shoe.
4. Securely tighten the two set screws to secure the wheel lock shoe extension to the wheel lock shoes.

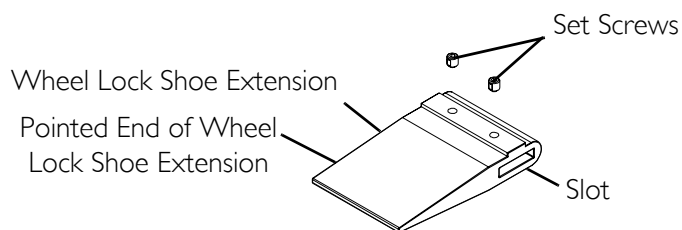

**FIGURE 9.5** Installing Wheel Lock Shoe Extensions

## SECTION 10—RECLINER

---

### **⚠ WARNING**

After any adjustments, repair or service and before use, make sure all attaching hardware is tightened securely. Otherwise injury or damage may occur.

---

## Operating Recliner

---

### **⚠ WARNING**

**ALWAYS** make sure that the wheelchair is stable before using the recliner option. **ALWAYS** wear your seat positioning strap. Inasmuch as the seat positioning strap is an option on this wheelchair (you may order with or without the seat positioning strap), Invacare strongly recommends ordering the seat positioning strap as an additional safeguard for the wheelchair user. The seat positioning strap is a positioning belt only. It is not designed for use as a safety device withstanding high stress loads such as auto or aircraft safety belts. If signs of wear appear, belt **MUST** be replaced **IMMEDIATELY**.

Ensure the spreader bar is attached and secured before using the 9000XT Recliner.

**LIFT KIT MODELS ONLY** - Both spring lift mechanisms **MUST** be operational before using the recliner. **DO NOT** operate the recliner option if only one of the spring lift mechanisms is operational.

#### **TO HEALTHCARE PROFESSIONALS/ASSISTANTS:**

Make sure occupant's hands and body are clear of all pinch points before reclining back. Pinch Points exist between spreader bar and recliner mechanism. Use caution, otherwise injury may occur.

When returning the occupant of the wheelchair to the full upright position, more body strength will be required for approximately the last twenty degrees of incline (reverse recline). Make sure to use proper body mechanics (use your legs) or seek assistance if necessary to avoid injury.

**LIFT KIT MODELS ONLY** - **DO NOT** attempt to recline or incline the wheelchair back without occupant. Back will raise abruptly and cause injury. Keep clear when reclining or inclining (reverse recline) chair back to avoid injury.

**ALWAYS** engage both wheel locks while reclining or inclining (reverse recline) the wheelchair.

Make sure the patient is properly positioned in the wheelchair before reclining or inclining (reverse recline) to maintain maximum stability and safety. Refer to **Safety/Handling of Wheelchairs** on page 17.

---

*NOTE: For this procedure, refer to FIGURE 10.1 on page 57.*

1. Unfold wheelchair. Refer to Safety/Handling of Wheelchairs on page 17.
  2. Attach spreader bar. Refer to Storing/Replacing Spreader Bar on page 60.
-



3. Adjust the tightness of the headrest/back upholstery. Refer to Adjusting Headrest/Back Upholstery Tension on page 58.
4. Make sure wheelchair is occupied and on a level surface before reclining.
5. Engage the wheel locks. Refer to Using/Adjusting Wheel Locks on page 62.
6. Inform the occupant of the wheelchair that the wheelchair is about to be reclined.
7. Make sure occupant's hands and body are clear of all pinch points.
8. Stand behind the wheelchair and grasp both push handles firmly.
9. Squeeze release handles.
10. Slowly pull back on the back assembly while squeezing the release handles.
11. When the back reaches the desired angle, slowly let go of the release handles.
12. To return the back to the full upright position, reverse STEPS 8-11 keeping in mind proper body mechanics.

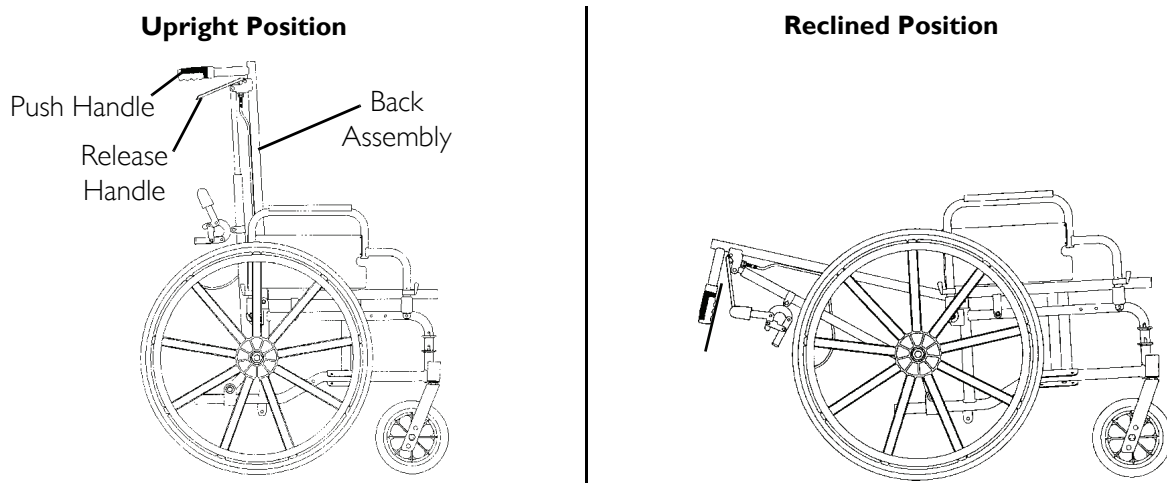
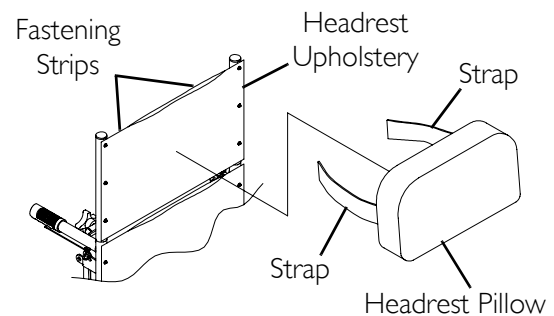

**FIGURE 10.1** Operating Recliner

## Replacing Headrest Pillow

*NOTE: For this procedure, refer to FIGURE 10.2.*

1. Unfasten straps of headrest pillow from behind headrest upholstery.
2. Secure straps of the new headrest pillow onto fastening strips located on back of headrest upholstery.



**FIGURE 10.2** Replacing Headrest Pillow

## Replacing Headrest/Back Upholstery

*NOTE: For this procedure, refer to FIGURE 10.3.*

### Headrest Upholstery

1. Remove the headrest pillow. Refer to [Replacing Headrest Pillow](#) on page 57.
2. Remove the six mounting screws that secure the headrest upholstery to the headrest extension tubes.
3. Secure new headrest upholstery onto headrest extension tubes with the existing six mounting screws.
4. Install headrest pillow. Refer to [Replacing Headrest Pillow](#) on page 57.

### Back Upholstery

1. Remove one knob from one side of the spreader bar.
2. Loosen, but DO NOT remove the remaining knob.

*NOTE: To remove and install the bottom two mounting screws of the back upholstery, the wheelchair MUST be partially folded.*

3. Remove the twelve mounting screws that secure the back upholstery to the back canes.
4. Secure the new back upholstery to the back canes with the existing twelve mounting screws. Securely tighten.
5. Install the knob removed in STEP 1 to secure spreader bar to side frame. Securely tighten both knobs.

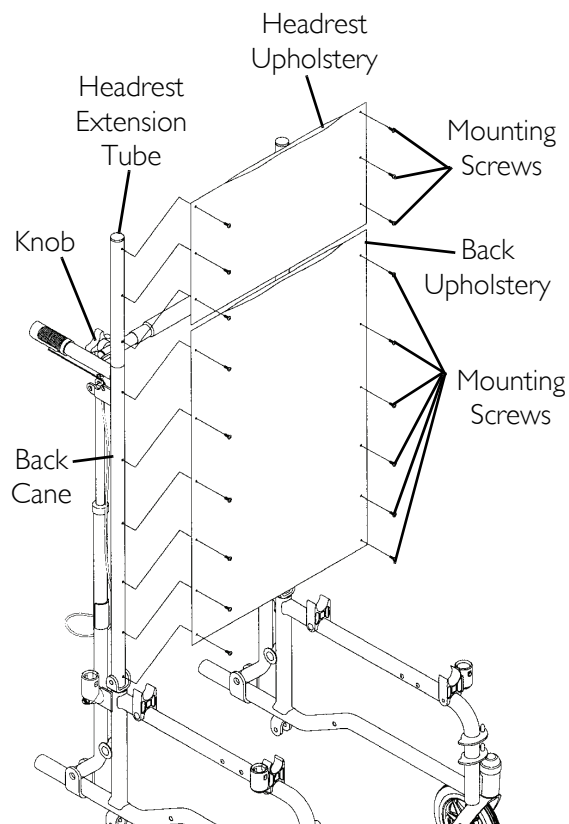
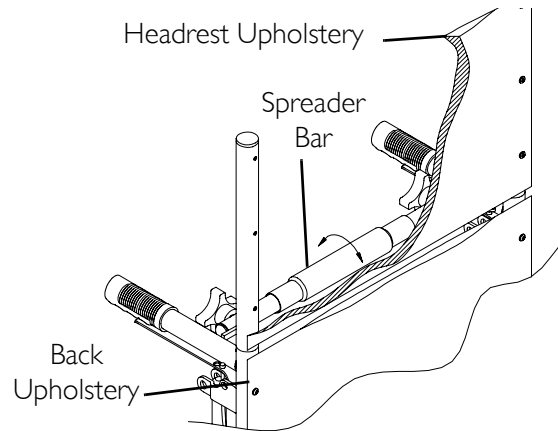

**FIGURE 10.3** Replacing Headrest/Back Upholstery

## Adjusting Headrest/Back Upholstery Tension

*NOTE: For this procedure, refer to FIGURE 10.4 on page 59.*

1. Rotate the spreader bar in one of the following directions:
  - Counterclockwise (away from back upholstery) to loosen back/headrest upholstery.
  - Clockwise (towards back upholstery) to tighten back/headrest upholstery.



**FIGURE 10.4** Adjusting Headrest/Back Upholstery Tension

## Adjusting Seat Depth

---

### **⚠ WARNING**

Adjusting the seat depth of the 9000XT Recliner **MUST** be performed by a qualified technician.

---

## Adjusting Seat Width

---

### **⚠ WARNING**

Adjusting the seat width of the 9000XT Recliner **MUST** be performed by a qualified technician.

---

## Storing/Replacing Spreader Bar

### Storing Spreader Bar

*NOTE: For this procedure, refer to FIGURE 10.5.*

*NOTE: The 9000XT Recliner is folded for either storage or transporting. One side of the spreader bar MUST be removed and placed in a vertical position alongside the recliner tube.*

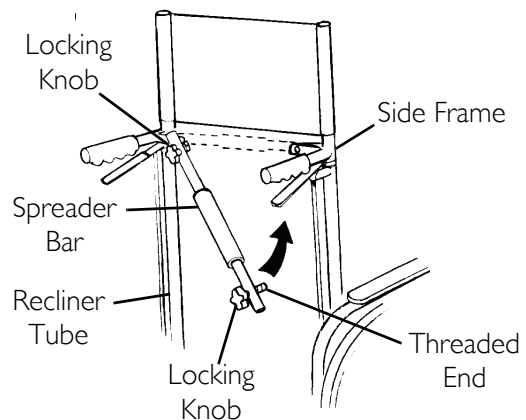

**FIGURE 10.5** Storing/Replacing Spreader Bar

### Removing From Stored Position

1. Rotate the end of the spreader bar 90° toward the opposite side frame.
2. Install threaded end of locking knob into locknut located on the opposite side frame. Securely tighten both knobs.

### Placing In Stored Position

1. Remove one locking knob from the spreader bar.
2. Loosen the remaining locking knob on the spreader bar.
3. Rotate detached end of the spreader bar 90° down toward floor.

### Replacing Spreader Bar

*NOTE: For this procedure, refer to FIGURE 10.6.*

1. Remove both locking knobs that secure the spreader bar to the side frames.
2. Remove existing spreader bar.
3. Secure new spreader bar to the side frames with the existing locking knobs. Securely tighten.

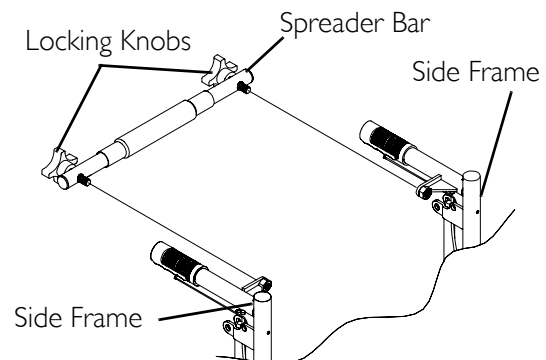

**FIGURE 10.6** Replacing Spreader Bar

## Installing Anti-Tippers

*NOTE: For this procedure, refer to FIGURE 10.7.*

1. Install the anti-rattles onto the rear frame tubes if not already in place (Detail "A").
2. Position the anti-tippers with the anti-tipper wheels pointing toward the ground/floor
3. Press the release buttons.
4. Insert the anti-tippers into the rear frame tubing until the bottom release button locks in place.

*NOTE: Refer to Detail "B" of FIGURE 10.7 and the following chart to ensure the correct anti-tipper is installed in the wheelchair. Seat-to-floor heights are approximate depending on front caster type. The anti-tipper height measurement **MUST** be taken with the anti-tipper on a flat surface.*

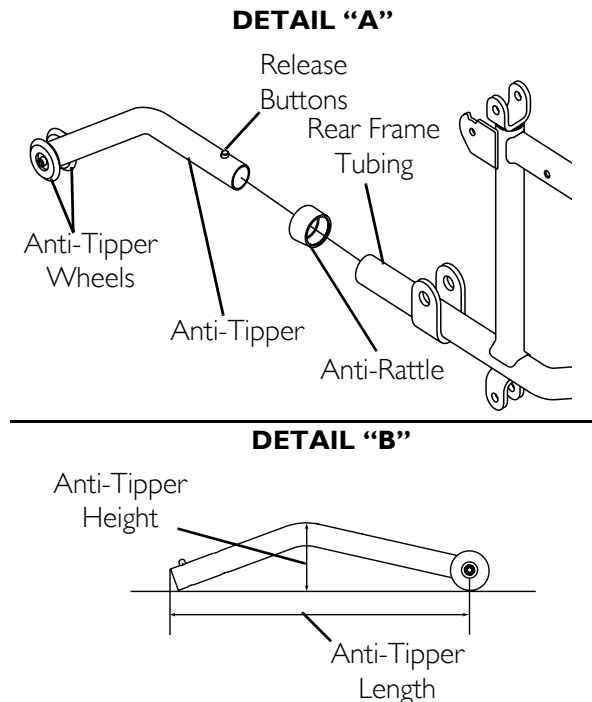

**FIGURE 10.7** Installing Anti-Tippers

9000 XT RECLINER				
WHEEL SIZE REAR/CASTER	SEAT-TO-FLOOR HEIGHT	ANTI-TIPPER LENGTH/HEIGHT	ON CHAIR	OFF CHAIR KIT NUMBER
24/8-inch	19½-inches	11½ / 2½-inches	1021767	1021767
22/8-inch	18½-inches	10¼ / 1-7/8-inches	1061110	1061110
20/8-inch	17½-inches	10 / 1½-inches	1061109	1061109

## Removing/Installing Rear Wheels

### **⚠ WARNING**

**Changing the size of the rear wheel or the seat-to-floor height **MUST** be performed only by a qualified technician.**

*NOTE: Use this procedure to replace a rear wheel with one of the same size.*

## With Patient Operated Wheel Locks

*NOTE: For this procedure, refer to FIGURE 10.8.*

1. Remove the axle mounting screw and locknut that secure the patient operated wheel lock, spacers, and rear wheel to the wheelchair frame.
2. Secure rear wheel, patient operated wheel lock, and spacers to wheelchair frame with axle mounting screw and locknut. Securely tighten.
3. Adjust the patient operated wheel locks. Refer to [Adjusting Patient-Operated Wheel Locks](#) on page 53.

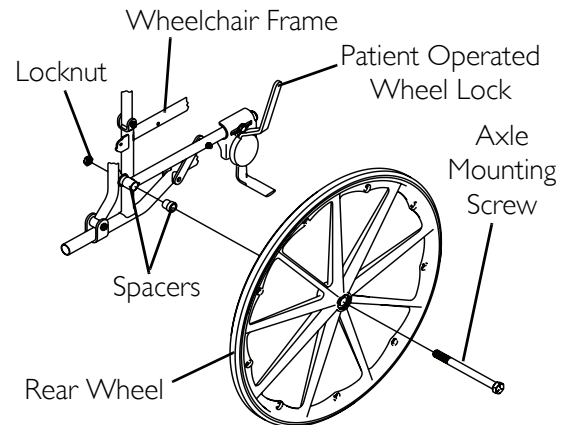
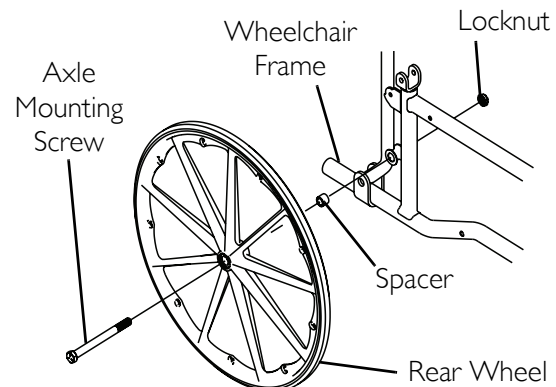

**FIGURE 10.8** Removing/Installing Rear Wheels - With Patient Operated Wheel Locks

## With Attendant Operated Wheel Locks

*NOTE: For this procedure, refer to FIGURE 10.9.*

1. Remove the axle mounting screw and locknut that secure the rear wheel and spacer to the wheelchair frame.
2. Remove rear wheel from side frame.
3. Secure rear wheel and spacer to wheelchair frame with axle mounting screw and locknut. Securely tighten.
4. Adjust the attendant operated wheel locks. Refer to [Adjusting Attendant Operated Wheel Locks](#) on page 63.



**FIGURE 10.9** Removing/Installing Rear Wheels - With Attendant Operated Wheel Locks

## Using/Adjusting Wheel Locks

*NOTE: For Using and/or Adjusting of Patient Operated Wheel Locks, refer to [Using/Adjusting Disk Wheel Locks](#) on page 52.*

## Using Attendant Operated Wheel Locks

### **⚠ WARNING**

**DO NOT attempt to stop a moving wheelchair with wheel locks. Wheel locks are not brakes.**

*NOTE: For this procedure, refer to FIGURE 10.10 on page 63.*

1. Perform one of the following:
  - Engage - Apply pressure downward on wheel lock handle.
  - Disengage - Lift up on wheel lock handle.

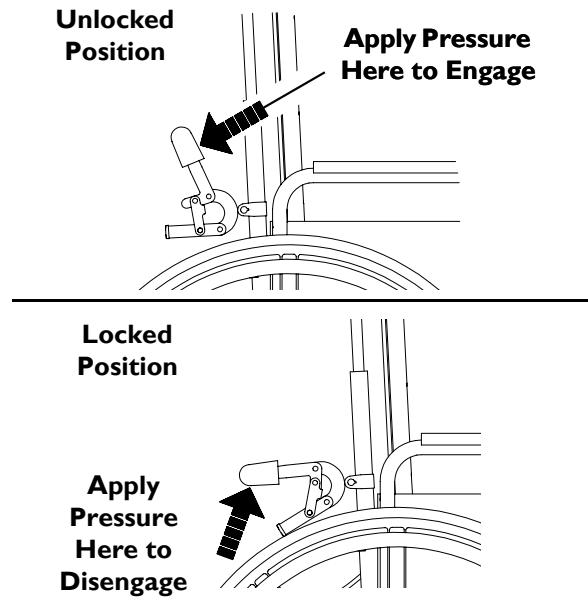

**FIGURE 10.10** Using Attendant Operated Wheel Locks

### Adjusting Attendant Operated Wheel Locks

*NOTE: For this procedure, refer to FIGURE 10.11 on page 64.*

*NOTE: If wheels are pneumatic, before adjusting or replacing the wheel lock assemblies, ensure that the tires are inflated to the recommended psi located on the side wall of tire.*

1. Loosen the bolt and locknut that secure the wheel lock to the recliner tube.
2. Adjust the position of wheel lock so that when engaged, the wheel lock shoe embeds the tire 1/8-inch (3/16-inch for pneumatic tires) and holds the wheelchair.
3. Securely tighten the bolt and locknut.
4. Engage wheel lock and push against the wheelchair and determine if wheel lock engages the wheel lock shoe enough to hold the wheelchair.
5. Repeat the above procedures until the wheel lock holds the wheelchair.
6. Repeat STEPS 1-5 for the opposite wheel lock.

*NOTE: Ensure the wheel lock shoe completely covers the tire contact area. See Detail "A" for proper positioning of wheel lock shoe.*

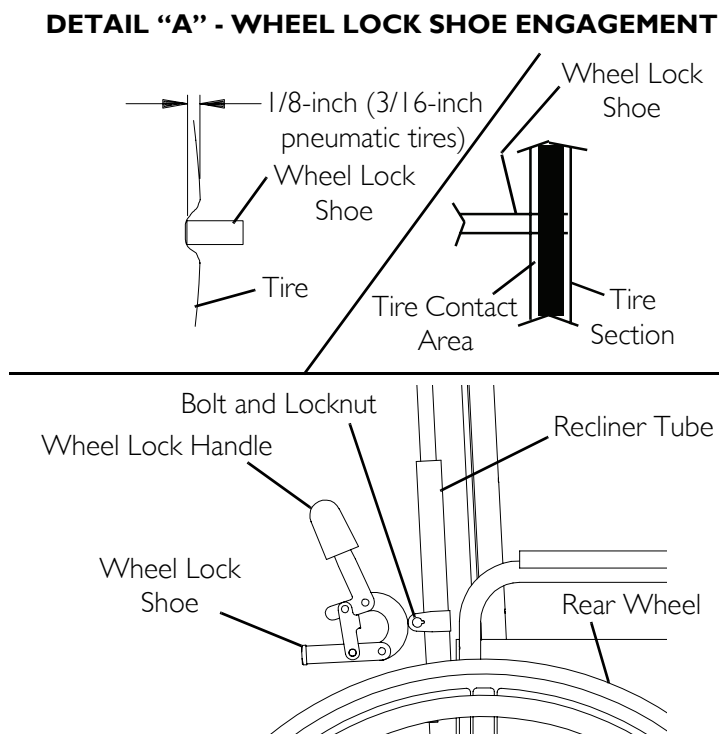

**FIGURE 10.11** Adjusting Attendant Operated Wheel Locks

## Installing Telescoping I.V. Rod

### Installing I.V. Holder

*NOTE: For this procedure, refer to FIGURE 10.12.*

1. Remove the rear wheel from the wheelchair. Refer to [Removing/Installing Rear Wheels](#) on page 61.
2. Remove the locknut and hex screw that secure the arm socket to the wheelchair frame (Detail "A").
3. Remove the locknut that secures the back tube to the clevis bracket (Detail "B").
4. Position the top hole on the flat portion of the I.V. holder on the existing pivot screw of the clevis bracket as shown in Detail "B".

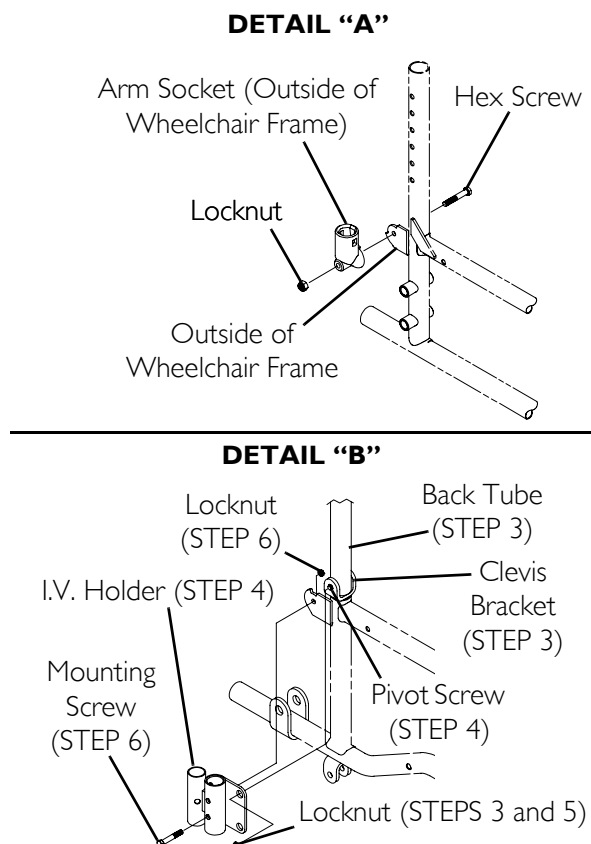

**FIGURE 10.12** Installing I.V. Holder

5. Reinstall locknut onto pivot screw. **DO NOT** tighten yet.



6. Thread the provided mounting screw through the lower hole on the front cylinder section of the I.V. holder, through the side frame, and into the locknut. Turn nut until snug fit is obtained. DO NOT tighten yet.
7. Reinstall the arm to orient front cylinder of I.V. holder. Refer to Removing or Replacing Armrest on page 38.
8. Once front cylinder is oriented for proper clearance of the armrest, securely tighten both locknuts.
9. Install the I. V. rod support tube. Refer to Installing I.V. Rod Support Tube on page 65.

### **Installing I.V. Rod Support Tube**

*NOTE: For this procedure, refer to FIGURE 10.13 on page 66.*

*NOTE: The I.V. rod holder MUST already be mounted to the side frame of the wheelchair.*

1. Insert the I.V. rod support tube into the rear cylinder of the I.V. rod holder.

*NOTE: When installing the I.V. rod support tube, ensure the adjustment knob is pointing out away from the wheelchair.*

2. Turn the I.V. rod support tube until the holes in the I.V. rod support tube align with the holes in the rear cylinder of the I.V. rod holder.
3. Insert mounting screw through rear cylinder, large nylon washer, small nylon washer, steel washer, and into locknut. Securely tighten.

*NOTE: The large nylon washer MUST be inserted into hole and pressed in so that it is flush with outside surface of rear cylinder.*

4. Reinstall the rear wheel from the wheelchair. Refer to Removing/Installing Rear Wheels on page 61.
5. Adjust I.V. rod to desired height. Refer to Adjusting I.V. Rod on page 65.

### **Adjusting I.V. Rod**

*NOTE: For this procedure, refer to FIGURE 10.13 on page 66.*

1. Loosen adjustment knob.
2. Adjust I.V. Rod to desired height.
3. Securely tighten adjustment knob.

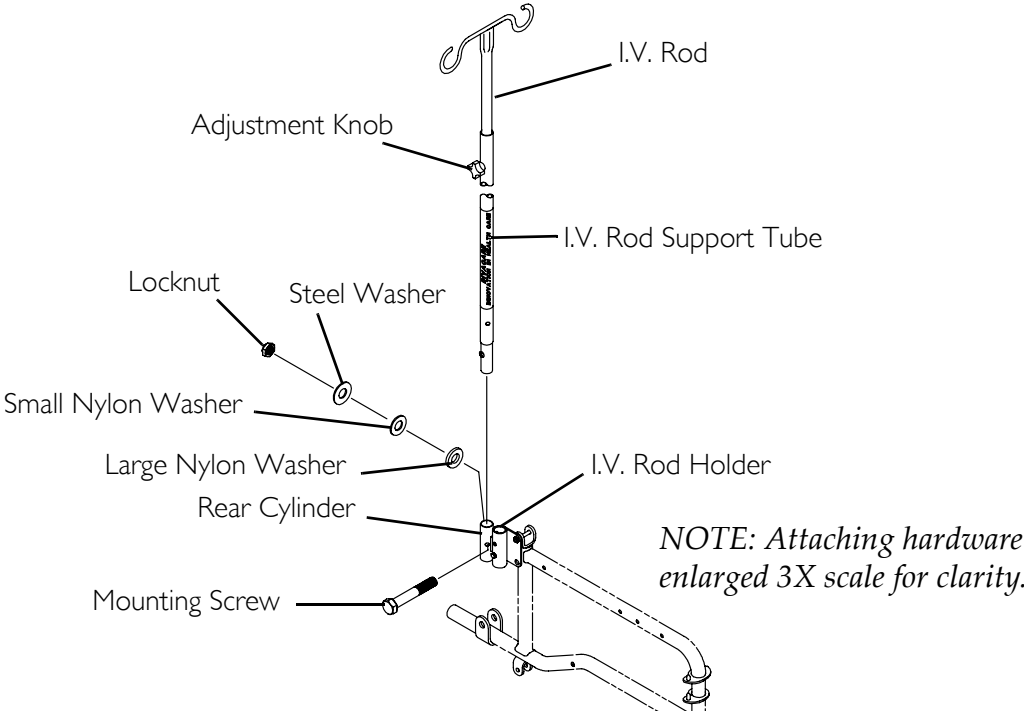

**FIGURE 10.13** Installing I.V. Rod Support Tube - Adjusting I.V. Rod

---

# SECTION 11—OPTIONS

---

## **⚠ WARNING**

**After any adjustments, repair or service and before use, make sure all attaching hardware is tightened securely. Otherwise injury or damage may occur.**

---

*NOTE: The options in this section refer to non-recliner models only. Refer to Recliner on page 56 for 9000XT Recliner options.*

## **Installing/Cleaning Telescoping I.V. Rod/O<sub>2</sub> Holders**

*NOTE: For this procedure, refer to FIGURE 11.1 on page 68.*

### **Installing**

---

## **⚠ WARNING**

The telescoping I.V. rod/O<sub>2</sub> holder **MUST** be checked weekly to ensure it is tightly secured to the wheelchair frame. If there is any looseness whatsoever, tighten the attachment hardware securely before using.

**TELESCOPING I.V. ROD HOLDER ONLY - Make sure the telescoping I.V. rod is tightly locked before placing I.V. medication on the rod.**

The telescoping I.V. rod is designed to support I.V. medication only. **DO NOT** use it to support objects other than I.V. medication.

---

1. Slide telescoping I.V. rod/O<sub>2</sub> holder over the step tube of the wheelchair.

*NOTE: Mounting bracket of telescoping I.V. rod/O<sub>2</sub> holder should be positioned between the two axle mounting positions on wheelchair frame.*

2. Secure telescoping I.V. rod/O<sub>2</sub> holder to the wheelchair frame with hex screw, spacer and locknut.
3. Telescoping I.V. Rod Holder Only - Secure the top of the telescoping I.V. rod holder to the wheelchair frame with a tie wrap.

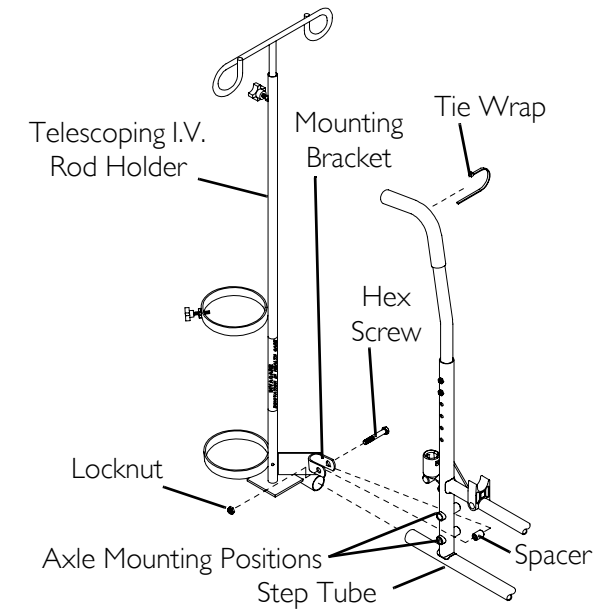
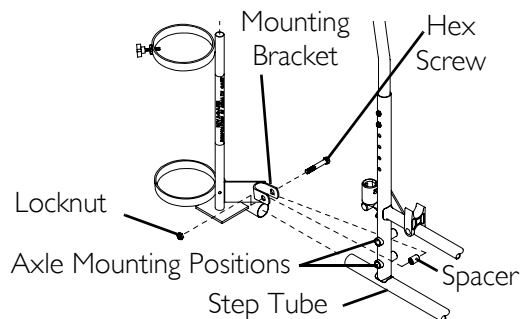
**DETAIL “A” - I.V. ROD/O<sub>2</sub> HOLDER****DETAIL “B” - O<sub>2</sub> HOLDER****FIGURE 11.1** Installing/Cleaning Telescoping I.V. Rod/O<sub>2</sub> Holders**Cleaning****⚠ WARNING**

The user and O<sub>2</sub> cylinder **MUST** be removed from the wheelchair when cleaning the O<sub>2</sub> holder. Otherwise, injury or damage may occur if cleaning agents come in contact with the O<sub>2</sub> regulator.

1. Remove the user, any I.V. medication and the O<sub>2</sub> cylinder from the wheelchair.
2. The telescoping I.V. rod/O<sub>2</sub> holders clean easily with any household glass type cleaner.
3. After the cleaning solution has dried, it is safe for the user to re-occupy the wheelchair.

## Installing Crutch and Cane Carrier

### ⚠ WARNING

Check base weekly to ensure proper placement.

When loading the crutch/cane carrier, ensure items are securely placed into the base. Also ensure that there is no interference with folding the wheelchair, the rear wheels, or the swing-back arms.

Strap **MUST** be securely fastened while carrying items.

**NEVER** insert or remove items while wheelchair is moving.

*NOTE: For this procedure, refer to FIGURE 11.2.*

1. Slide the clamp with the base attached over the end of the step tube of the wheelchair. Ensure the base is towards the inside of the wheelchair.
2. Position the base parallel to the step tube.

### CAUTION

Base should be parallel to step tube to avoid bending spokes when folding the wheelchair.

3. Securely tighten the locknut that secures the base to the step tube of the wheelchair.
4. Remove the upper back upholstery screw and washer.
5. Align the strap with the back upholstery screw mounting hole.
6. Reinstall the back upholstery screw and washer and secure the strap to the wheelchair.
7. The base cleans easily with any chrome or glass cleaner. The strap can be cleaned with mild soap and water.

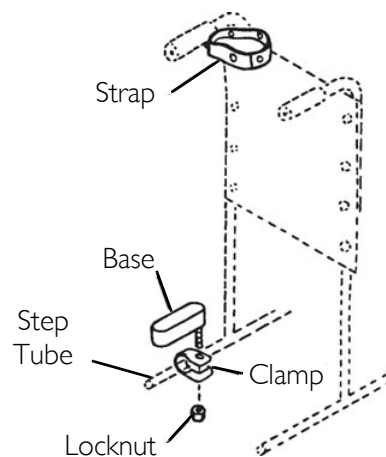

**FIGURE 11.2** Installing Crutch and Cane Carrier

## Installing Amputee Bracket

### Super Hemi Models

*NOTE: For this procedure, refer to FIGURE 11.3 on page 70.*

1. Remove the plug button or anti-tipper from the step tube of the wheelchair frame.
2. Slide the amputee attachment over the step tube of the wheelchair.

3. Secure the amputee attachment to the wheelchair with the hex screw, spacer and locknut.
4. Reinstall the plug button or anti-tipper onto the step tube of the wheelchair frame.
5. Repeat STEPS 1-4 for the opposite side of the wheelchair.
6. Reposition the rear wheels. Refer to Removing/Installing Rear Wheels on page 44.

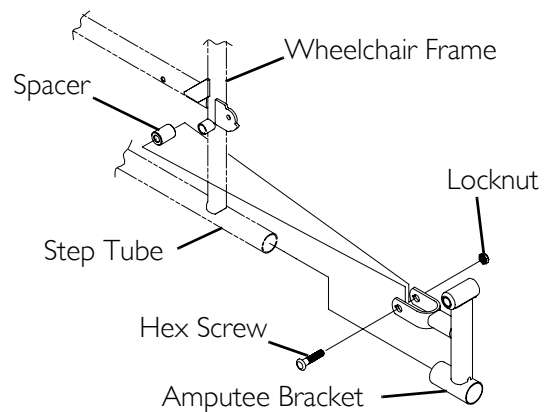

**FIGURE 11.3** Installing Amputee Bracket

### 9000SL/XT

*NOTE: For this procedure, refer to FIGURE 11.4 on page 71.*

1. Refer to the following chart or FIGURE 11.4 to determine the mounting position of the amputee bracket:

SEAT-TO-FLOOR	*BRACKET	AXLE SPACER POSITION (ON BRACKET)	SIDE OF WHEELCHAIR	AXLE MOUNTING POSITION (ON WHEELCHAIR)
ADULT	A	DOWN	RIGHT	TOP
ADULT	B	DOWN	LEFT	TOP
HEMI	B	UP	RIGHT	BOTTOM
HEMI	A	UP	LEFT	BOTTOM

*\*NOTE: "A" and "B" are stamped on the sides of the amputee bracket.*

2. Install the amputee bracket on the wheelchair frame to the position determined in STEP 1.

*NOTE: Make sure the axle spacer is pointing towards the outside of the wheelchair.*

3. Install the two hex screws and locknuts that secure the amputee bracket to the wheelchair.
4. Install the rear wheels onto the wheelchair. Refer to Removing/Installing Rear Wheels on page 44.

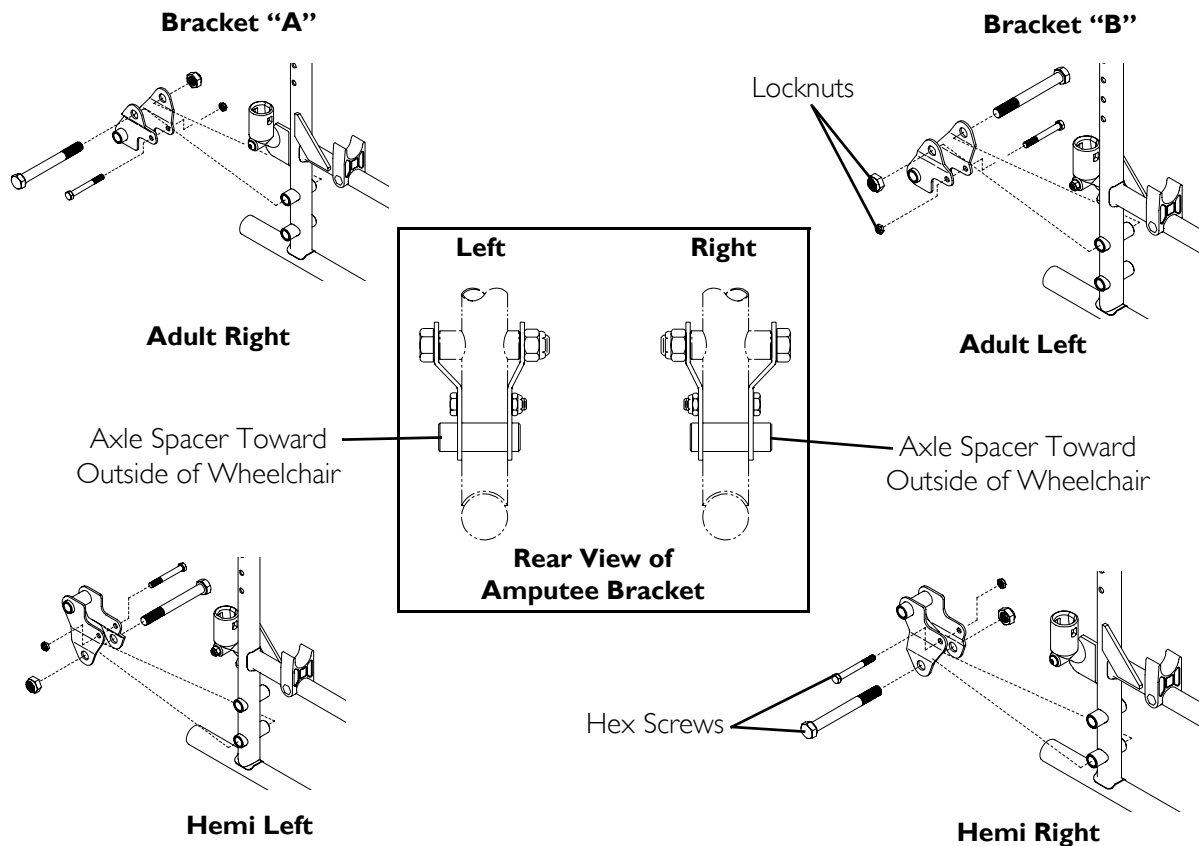

**FIGURE 11.4** Installing Amputee Bracket - 9000SL/XT

### 9000XDT

*NOTE: For this procedure, refer to FIGURE 11.5 on page 72.*

1. Refer to the following chart or FIGURE 11.5 to determine the mounting position of the amputee bracket:

SEAT-TO-FLOOR	*BRACKET	AXLE SPACER POSITION (ON BRACKET)	SIDE OF WHEELCHAIR	AXLE MOUNTING POSITION (ON WHEELCHAIR)
TALL	A	DOWN	RIGHT	MIDDLE
TALL	B	DOWN	LEFT	MIDDLE
ADULT	B	UP	RIGHT	BOTTOM
ADULT	A	UP	LEFT	BOTTOM
HEMI	B	UP	RIGHT	MIDDLE
HEMI	A	UP	LEFT	MIDDLE

*\*NOTE: "A" and "B" are stamped on the sides of the amputee bracket.*

2. Install the amputee bracket on the wheelchair frame to the position determined in STEP 1.

*NOTE: Make sure the axle spacer is pointing towards the outside of the wheelchair.*

3. Install the two (2) hex screws and locknuts that secure the amputee bracket to the wheelchair.

4. Install the rear wheels onto the wheelchair. Refer to Removing/Installing Rear Wheels on page 44.

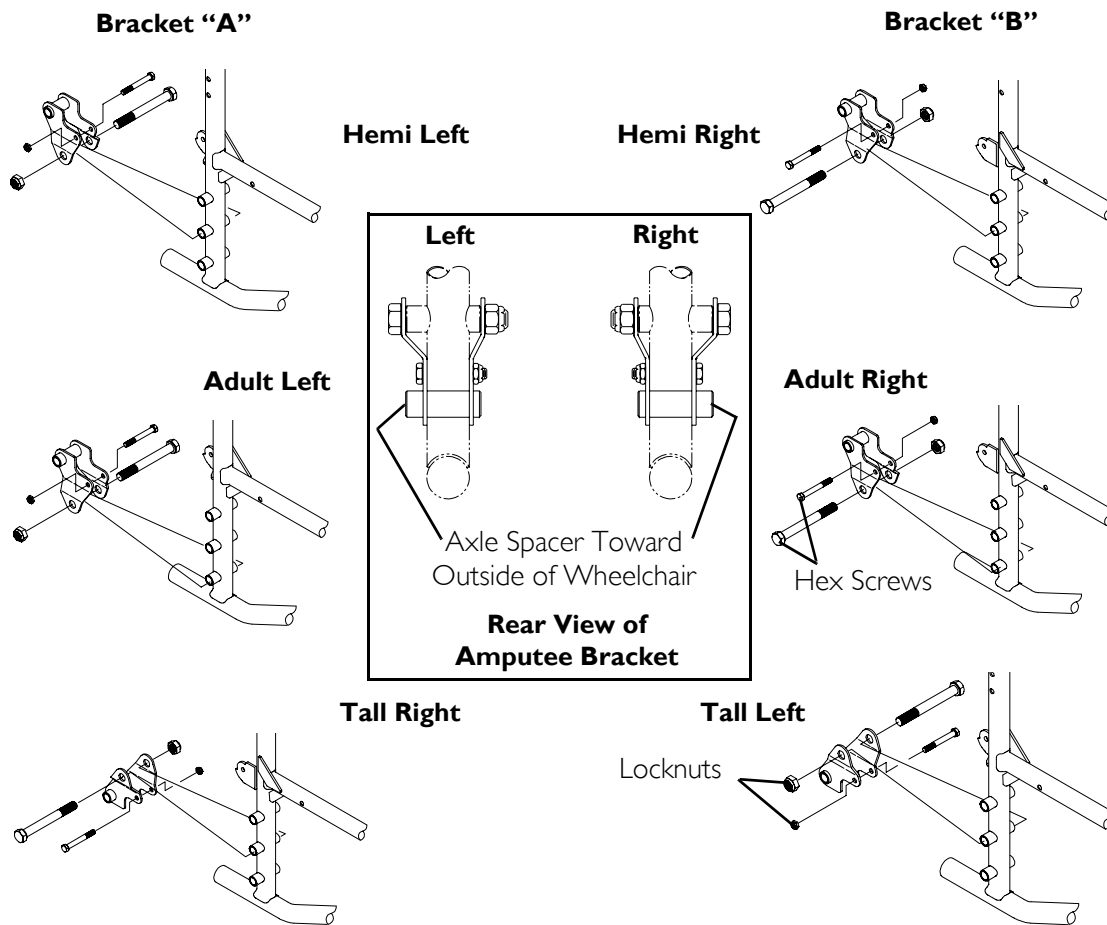

**FIGURE 11.5** Installing Amputee Bracket - 9000XDT



# NOTES

# NOTES

---

# LIMITED WARRANTY

**PLEASE NOTE: THE WARRANTY BELOW HAS BEEN DRAFTED TO COMPLY WITH FEDERAL LAW APPLICABLE TO PRODUCTS MANUFACTURED AFTER JULY 4, 1975.**

This warranty is extended only to the original purchaser who purchases this product when new and unused from Invacare or a dealer. This warranty is not extended to any other person or entity and is not transferable or assignable to any subsequent purchaser or owner. Coverage under this warranty will end upon any such subsequent sale or other transfer of title to any other person.

This warranty gives you specific legal rights and you may also have other legal rights which vary from state to state.

Invacare warrants the side frames and cross members of this product when purchased new and unused to be free from defects in materials and workmanship for a period of five (5) years from the date of purchase from Invacare or a dealer, with a copy of the seller's invoice required for coverage under this warranty. Invacare warrants the upholstered materials (seat, back and armrests of the arm assembly) and remaining components of this product when purchased new and unused to be free from defects in materials and workmanship for a period of thirteen (13) months from date of purchase from Invacare or a dealer, with a copy of the seller's invoice required for coverage under this warranty. If within such warranty periods any such product shall be proven to be defective, such product shall be repaired or replaced, at Invacare's option. This warranty does not include any labor or shipping charges incurred in replacement part installation or repair of any such product. Invacare's sole obligation and your exclusive remedy under this warranty shall be limited to such repair and/or replacement.

For warranty service, please contact the dealer from whom you purchased your Invacare product. In the event you do not receive satisfactory warranty service, please write directly to Invacare at the address at the bottom of this page. Provide dealer's name, address, the product model number, date of purchase, indicate nature of the defect and, if the product is serialized, indicate the serial number. Do not return products to our factory without our prior consent.

**LIMITATIONS AND EXCLUSIONS: THE FOREGOING WARRANTY SHALL NOT APPLY TO SERIAL NUMBERED PRODUCTS IF THE SERIAL NUMBER HAS BEEN REMOVED OR DEFACED, PRODUCTS SUBJECTED TO NEGLIGENCE, ACCIDENT, IMPROPER OPERATION, MAINTENANCE OR STORAGE, PRODUCTS MODIFIED WITHOUT INVACARE'S EXPRESS WRITTEN CONSENT INCLUDING, BUT NOT LIMITED TO, MODIFICATION THROUGH THE USE OF UNAUTHORIZED PARTS OR ATTACHMENTS; PRODUCTS DAMAGED BY REASON OF REPAIRS MADE TO ANY COMPONENT WITHOUT THE SPECIFIC CONSENT OF INVACARE, OR TO A PRODUCT DAMAGED BY CIRCUMSTANCES BEYOND INVACARE'S CONTROL, AND SUCH EVALUATION WILL BE SOLELY DETERMINED BY INVACARE. THE WARRANTY SHALL NOT APPLY TO NORMAL WEAR AND TEAR OR FAILURE TO ADHERE TO THE PRODUCT INSTRUCTIONS.**

**THE FOREGOING EXPRESS WARRANTY IS EXCLUSIVE AND IN LIEU OF ANY OTHER WARRANTIES WHATSOEVER, WHETHER EXPRESS OR IMPLIED, INCLUDING THE IMPLIED WARRANTIES OF MERCHANTABILITY AND FITNESS FOR A PARTICULAR PURPOSE, AND THE SOLE REMEDY FOR VIOLATIONS OF ANY WARRANTY WHATSOEVER, SHALL BE LIMITED TO REPAIR OR REPLACEMENT OF THE DEFECTIVE PRODUCT PURSUANT TO THE TERMS CONTAINED HEREIN. THE APPLICATION OF ANY IMPLIED WARRANTY WHATSOEVER SHALL NOT EXTEND BEYOND THE DURATION OF THE EXPRESS WARRANTY PROVIDED HEREIN. INVACARE SHALL NOT BE LIABLE FOR ANY CONSEQUENTIAL OR INCIDENTAL DAMAGES WHATSOEVER.**

**SOME STATES DO NOT ALLOW THE EXCLUSION OR LIMITATION OF INCIDENTAL OR CONSEQUENTIAL DAMAGE, OR LIMITATION OF HOW LONG AN IMPLIED WARRANTY LASTS, SO THE ABOVE EXCLUSION AND LIMITATION MAY NOT BE APPLICABLE.**

**THIS WARRANTY SHALL BE EXTENDED TO COMPLY WITH STATE/PROVINCIAL LAWS AND REQUIREMENTS.**



***Yes, you can.***

---

**Invacare Corporation** [www.invacare.com](http://www.invacare.com)

**USA**  
One Invacare Way  
Elyria, Ohio USA  
44036-2125  
800-333-6900

**Canada**  
570 Matheson Blvd E Unit 8  
Mississauga Ontario  
L4Z 4G4 Canada  
800-668-5324

All rights reserved. Trademarks are identified by <sup>™</sup> and <sup>®</sup>. All trademarks are owned by or licensed to Invacare Corporation unless otherwise noted. Teflon is a registered trademark of DuPont. 3-in-1 is a registered trademark of American Home Products Corporation.

© 2007 Invacare Corporation

Part No. 1056953

Rev O - 12/07