

Type	_____			
	-09	-10	-20	-33
P3190	<input type="checkbox"/>	<input type="checkbox"/>	<input type="checkbox"/>	<input type="checkbox"/>
P3191	<input type="checkbox"/>	<input type="checkbox"/>	<input type="checkbox"/>	<input type="checkbox"/>
P3192	<input type="checkbox"/>	<input type="checkbox"/>	<input type="checkbox"/>	<input type="checkbox"/>
P3193	<input type="checkbox"/>	<input type="checkbox"/>	<input type="checkbox"/>	<input type="checkbox"/>

Catalog No.	Finish				Lamping	Dimensions (Inches)			
	Brushed Nickel	Polished Brass	Antique Bronze	Cobblestone		A	B	C	D
P3190	-09	-10	-20	-33	1 (m) 100w	6-1/2	11	9-3/8	3-3/4
P3191	-09	-10	-20	-33	2 (m) 100w	17-1/2	11	7-1/2	5-3/4
P3192	-09	-10	-20	-33	3 (m) 100w	24	11	7-1/2	5-3/4
P3193	-09	-10	-20	-33	4 (m) 100w	33-1/4	11	7-1/2	5-3/4

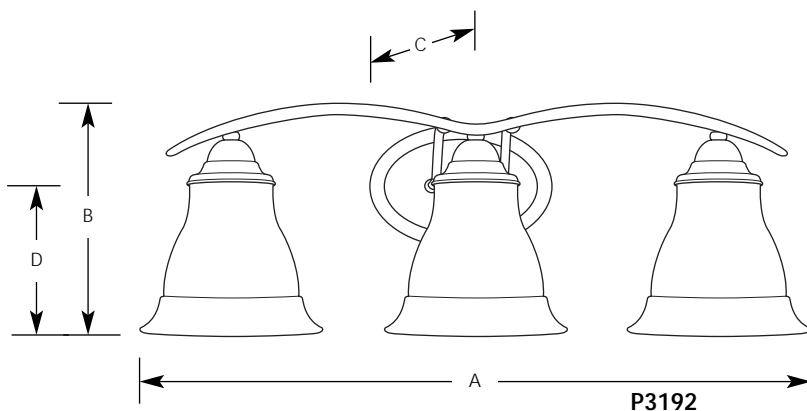
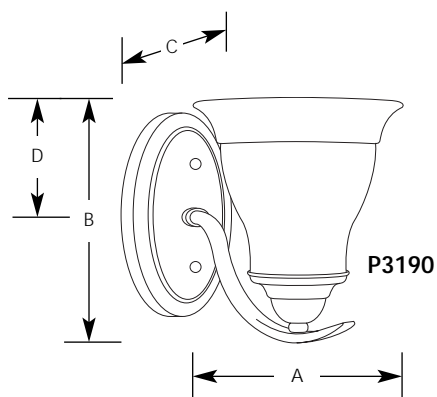

Specifications:

General

- Etched glass shades with slight banding
- Oval tubing with pinched ends
- Brushed Nickel (-09) and Polished Brass (-10) finishes are plated
- Antique Bronze (-20) and Cobblestone (-33) are hand painted
- Steel Construction
- Companion chandelier, hall and foyer, pendant, close to ceiling, and wall bracket units

Mounting

- Wall mounted
- Canopy covers a standard 4" hexagonal outlet box
- Mounting strap for outlet box included
- Threaded socket ring secures glass

Electrical

- Ceramic medium based sockets
- Pre-wired

Labeling

- UL-CUL damp location listed

Progress Lighting
 Post Office Box 5704
 Spartanburg, South Carolina
 29304-5704