

Type _____

-77

P4022

P4023

P4024

Catalog No.	Finish	Lamping	Dimensions (Inches)		
	Forged Bronze		A	B	C
P4022	-77	3(m) 100w	19-3/4	19-5/8	95
P4023	-77	5(m) 100w	26-1/2	24-1/4	100
P4024	-77	9(m) 100w	31-1/4	36-3/8	160

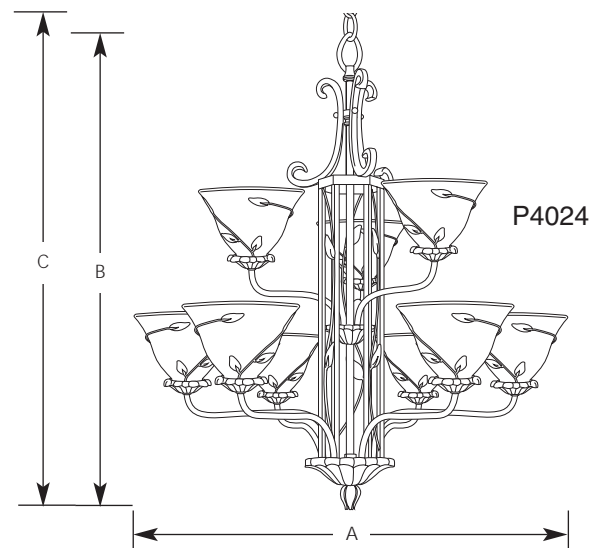
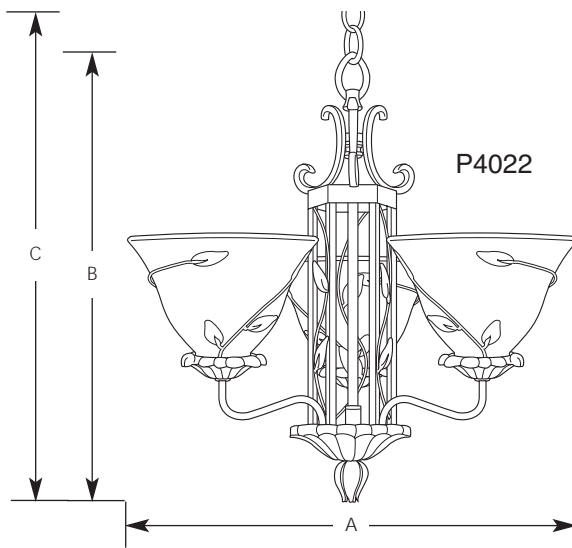

Specifications:

General

- Amber linen textured glass shades
- Shades surrounded with unique metal leaf design
- Leaf accents in center column
- P4024 is a two tier unit (6/3)
- 6 feet of 9 gauge matching chain on P4022 and P4023. P4024 has 10 feet of 9 gauge chain.
- Forged iron and steel construction
- Hand painted forged bronze finish
- Companion hall & foyer, wall bracket, mini-pendant, close to ceiling, and bath & vanity units

Mounting

- Chain hung ceiling
- Canopy covers a standard recessed 4" octagonal outlet box
- Mounting strap for outlet box included

Electrical

- 15 feet of wire
- Ceramic medium based sockets
- Pre-wired

Labeling

- UL-CUL listed