

Type \_\_\_\_\_

-09    -20

P3757       

Catalog No.	Finish		Lamping	Dimensions (Inches)		
	Brushed Nickel	Antique Bronze		A	B	C
	P3757	-09		-20	3 (m) 100w	18-1/4

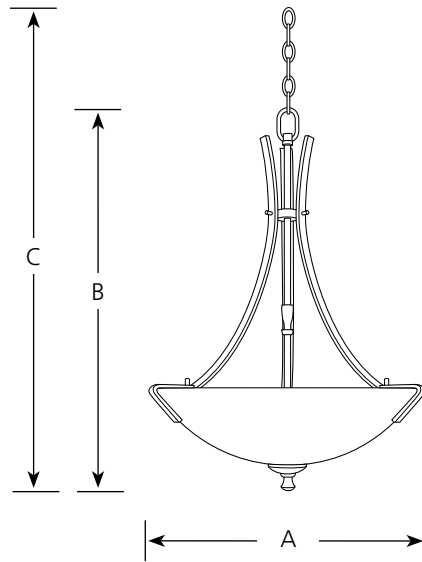

**Specifications:**

General

- Etched glass bowl with curved support accents, 18-1/4" dia. x 4-5/8" T
- Brushed Nickel (-09) finish is plated
- Antique Bronze (-20) is hand painted
- Steel construction
- 6 feet of 9 gauge matching chain supplied
- Companion chandelier, hall and foyer, pendant, close to ceiling, wall bracket, and bath and vanity units

Mounting

- Ceiling chain mounted
- Canopy covers a standard 4" hexagonal outlet box
- Mounting strap for outlet box included

Electrical

- Ceramic medium based sockets
- 15 feet of wire
- Pre-wired

Labeling

- UL-CUL listed

Type \_\_\_\_\_  
 -09EBWB -20EBWB  
 P3757

Catalog No.	Finish		Lamping	Dimensions (Inches)		
	Brushed Nickel	Antique Bronze		A	B	C
P3757	-09EBWB	-20EBWB	3 13w CFL (Included)	18-1/4	25	100

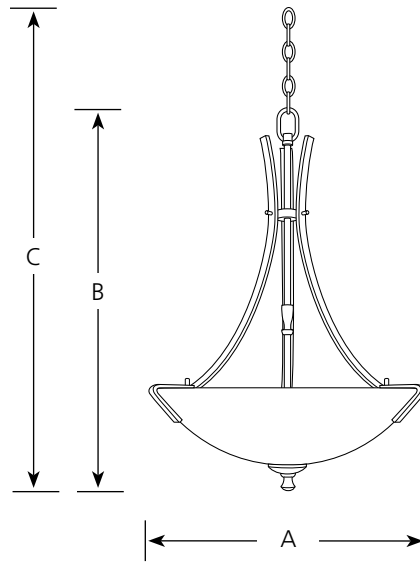

**Specifications:**

General

- Etched glass bowl with curved support accents, 18-1/4" dia. x 4-5/8" T
- Three 13 watt Compact Fluorescent lamps included
- Brushed Nickel (-09) finish is plated
- Antique Bronze (-20) is hand painted
- Steel construction
- 6 feet of 9 gauge matching chain supplied
- Companion chandelier, hall and foyer, pendant, close to ceiling, wall bracket, and bath and vanity units

Mounting

- Ceiling chain mounted
- Canopy covers a standard 4" hexagonal outlet box
- Mounting strap for outlet box included

Electrical

- GU24 based sockets
- 15 feet of wire
- Pre-wired

Labeling

