

Type _____

-09

P4626

Finish

Catalog No.	Brushed Nickel	Lamping	Dimensions (Inches)		
			A	B	C
P4626	-09	9 (m) 100w	28	28-1/2	102

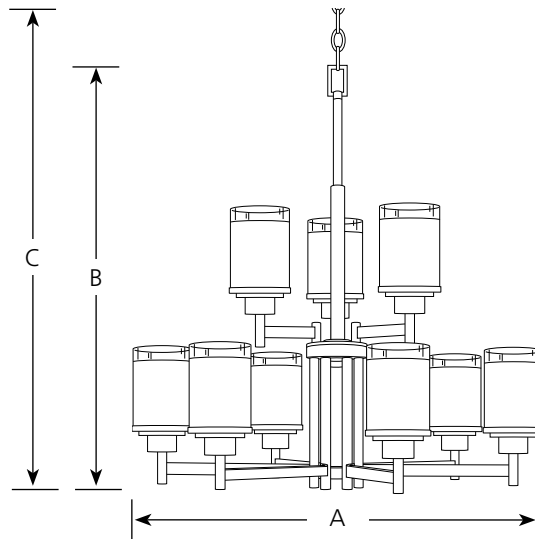

Specifications:

General

- Clear glass shades with etched/linen pattern on the outside (-09): 4" dia. x 5-9/16" ht.
- Plated Brushed Nickel (-09) finish
- Steel construction
- Six feet of 9 gauge chain supplied.
- Companion Bath and Vanity, Chandelier, Hall and Foyer, Pendant, Wall Bracket, fixtures are available

Electrical

- Medium base ceramic sockets
- 15 feet of wire supplied
- Pre-wired

Labeling

- UL-CUL listed

Mounting

- Ceiling chain mount
- Canopy covers a standard 4" hexagonal recessed outlet box
- Mounting strap for outlet box included