

OWNERS MANUAL

DM450 & DM500 CORE DRILLS



clipper

FORM <<7125 8/00

WARRANTY

Norton Construction Products warrants all products manufactured by it against defects in workmanship or materials for a period of one (1) year from the date of shipment to the customer.

The responsibility of Norton Construction Products under this warranty is limited to replacement or repair of defective parts at Norton Construction Products's Gainesville, Georgia factory, or at a point designated by it, of such part as shall appear to us upon inspection at such point, to have been defective in material or workmanship, with expense for transportation borne by the customer.

In no event shall Norton Construction Products be liable for consequential or incidental damages arising out of the failure of any product to operate properly.

Integral units such as **gasoline engines, electric motors, batteries, tires, transmissions, etc.**, are excluded from this warranty and are subject to the prime manufacturer's warranty.

This warranty is in lieu of all other warranties, expressed or implied, and all such other warranties are hereby disclaimed.

Important: Before placing equipment in operation, record the following information.

MODEL: _____ **SERIAL NO.** _____

PURCHASE FROM: _____

ADDRESS: _____

CITY _____ **STATE** _____ **ZIP** _____

TELEPHONE NO. _____

Before using this equipment, make sure that person using it read and understand the instructions in this owners manual.

DM450 & DM500 CORE DRILL

CONTENTS	PAGE
GENERAL INFORMATION	
Warranty Information	Inside Cover
I. Preparation	
A. Safety Precautions	4
B. General Information	5
C. Bit Installation	5
D. Water Supply	5
E. Electrical Supply	6
II. Operation	
A. Core Drill Positioning	7
B. Drilling Technique	7
C. Vacuum Hold Down Operation[Optional]	8
D. Water Collector Operation [Optional]	8
III. Maintenance and Component Description	
A. Motor Specifications [Dewalt]	9
B. Motor Specifications [Milwaukee]	10
C. Vacuum Pump	11
D. Leveling Screws	11
E. Carriage	11
F. Gibs	12
G. Motor Spindle	12
H. Vacuum Seal	12
I. Electrical Wiring Diagram	13
IV. Parts List Section	
A. Ordering Information	14
B. Optional Accessories	14
C. Assembly Drawings	16-19
D. Service Parts List	16-19
E. Operating & Maintenance Instructions Gast Vacuum Pump	20
F. Dewalt Authorized Distributors	23-26
G. Milwaukee Authorized Distributors	27
H. Gast Pump Authorized Distributors	28
I. Machine Service Log	

I PREPARATION

A. Safety Precautions

IMPORTANT! THE FOLLOWING SAFETY PRECAUTIONS MUST BE OBSERVED.

1. **Know your core drilling machine!** Read the Operator's manual carefully. Learn the operation, application and limitations, as well as the specific potential hazards peculiar to this equipment.
2. **Ground the machine!** The core drill must be grounded while in use to protect the operator from electric shock. The motor is equipped with a three prong grounding type plug to fit the proper type receptacle. The green [or green & yellow] conductor in the cord is grounding wire.
3. **NEVER** connect the green [or green & yellow] wire to a live terminal.
4. Use only three-wire grounded extension cords suitable for use outdoors and of sufficient gage to accommodate power requirements.
5. Replace frayed or damaged extension cords.
6. Keep the work area clean avoiding cluttered work areas.
7. Consider the work area environment!
 - Do not expose power tools to rain.
 - Wear rubber boots to further insulate yourself from the drill.
 - Mop up all excessive water around the work area before and after drilling.
 - Keep the work area well lit.
8. Use extreme caution when drilling through floors. Provide for protection of all personnel and material below the area. Cores generally drop from the drill bit at the completion of the hole.
9. Keep visitors away. Do not let visitors contact tool or extension cord. All visitors should be kept at a safe distance from the work area.
10. Do not force the bit into the drilling surface.
 - Use an anchor bolt , ceiling jack or vacuum hold-down attachment when drilling vertically (↓↑) into floors.
 - Only use an anchor bolt or ceiling jack when drilling horizontally (↔) into a wall or any other vertical surface.
11. Dress properly for the work being performed.
 - Do not wear loose clothing or jewelry which can get caught in moving or rotating parts.
 - Rubber gloves and non-skid footwear is recommended when working outside.
 - Wear protective covering to contain long hair.
12. Don't abuse the cord. Never carry the tool by the cord or yank the cord to disconnect the plug from the receptacle.
13. Secure the drill stand to the work surface. Use an anchor bolt, ceiling jack or vacuum attachment to secure the drill stand to the work surface.
14. **NEVER** stand on the drill stand base as a method of securing the drill stand!
15. Don't overreach! Keep proper footing and balance at all times. The slippery surface created during the drilling operation results in unstable footing.
16. **ALWAYS** disconnect the power before servicing or changing accessories or bits.
17. **ALWAYS** check, then make sure wrenches are removed from the motor spindle and bit adapter before connecting power or starting the drill motor.
18. **ALWAYS** make sure power switch is in "off" position before connecting drill to power.

Caution: It is very important that the drilling machine is properly secured to the work surface. Movement during drilling will cause bit chatter against work surface, fracturing diamonds or binding bit in the hole.

I PREPARATION

B. General Information

The DM450 & DM500 core drills are available with different power units.

MANUFACTURER	AMPS	VOLTS	PHASE	HERTZ
MILWAUKEE	15	115	SINGLE	60
DEWALT	20	115	SINGLE	60
MILWAUKEE	20	115	SINGLE	60

All motors are **single phase** with two-speed selector switches. The **115 volt** motors will operate within a power range of 110 to 120 volts.

C. Bit Installation

The threads on the output spindle of the core drill motors have dimensions of 1-1/4"-7. Core bits are available in a variety of diameters. The spindle thread on the adapter nut of the core bit is 5/8"-11 on smaller diameter bits. The use of an adapter coupling part number 400148 is required in order to run smaller diameter bits. The adapter provides a coupling which has a female 1-1/4"-7 thread on one side and a 5/8"-11 spindle on the other end.

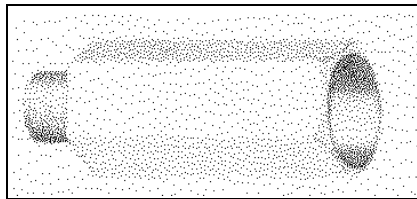

**Core Bit Adapter
Part Number 400148**

1. Using a wrench to firmly hold the output shaft , screw the core bit onto the spindle until snug.
2. Placing one wrench on the machined flats of the output shaft and one wrench on the end adapter of the core bit tighten the bit on the spindle. **Note:** Attempting to turn the bit by the barrel rather than by the adapter nut may break the weld between the adapter nut plate and the barrel.

D. Water Supply

It is important when wet cutting to maintain an adequate supply of clean water to the diamond drill bits. The hose input adapter on the water swivel at the base of the core drill motor is used to connect the water supply hose to the core drilling unit. Special precautions should be taken to insure that the water supply will not be interrupted during the drilling operation.

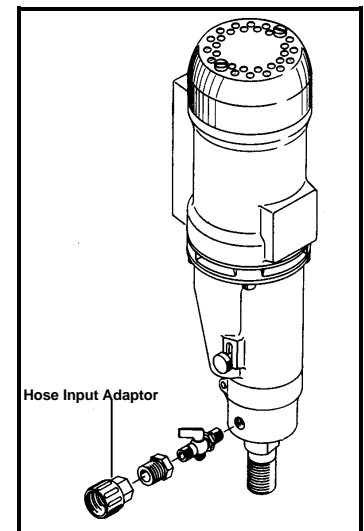

I PREPARATION

E. Electrical Supply

The DM450 & DM500 core drills are furnished with 115 volt, single phase motors. These motors operate within a power range of 110 to 120 volts. Serious damage can result if the supply line voltage does not fall within this range.

The following wire sizes are recommended when using an extension cord:

DISTANCE FROM SOURCE	115 volt 25 FEET	115 volt 50 FEET	115 volt 75 FEET	115 volt 100 FEET
Wire Gauge	# 14	# 12	# 10	# 08

The DM450 & DM500 core drills are manufactured with a three conductor connector cord which attaches the motor to the electrical supply. The green wire provided is used to connect to a permanent ground.

- a. Before connecting the drill to the power source, make sure that the voltage and cycles shown on the name plate of the motor are the same as the available electrical power supplied.
- b. Always properly ground the core drill before attempting to start the motor. The presence of water during the drilling operation requires that the drill always be properly grounded.
- c. **NEVER connect the green wire to a live terminal !**

The use of 3-prong adapter is prohibited in Canada by the Canadian Electrical Code.

An adapter, Fig. "B" is available for connecting Fig. A plugs to two prong receptacles. The green grounding ear extending from adapter must be connected to a permanent ground such as to properly grounded outlet box. No adapter is available for fig "C" plugs.

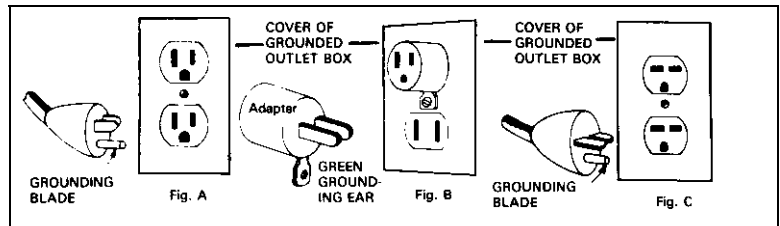

NOTE: RECEPTACLE MUST BE GROUNDED FOR SAFE USE OF ADAPTER:
IF IN DOUBT CALL A QUALIFIED ELECTRICIAN AND HAVE THE RECEPTACLE CHECKED FOR GROUNDING.

To connect twist lock plugs like those shown in figures D and E, insert the plug into a matching outlet. When the plug is fully inserted, turn it clockwise until it locks. This prevents the plug from being pulled out accidentally. To remove the plug, twist it counterclockwise to unlock it and remove it from the outlet.

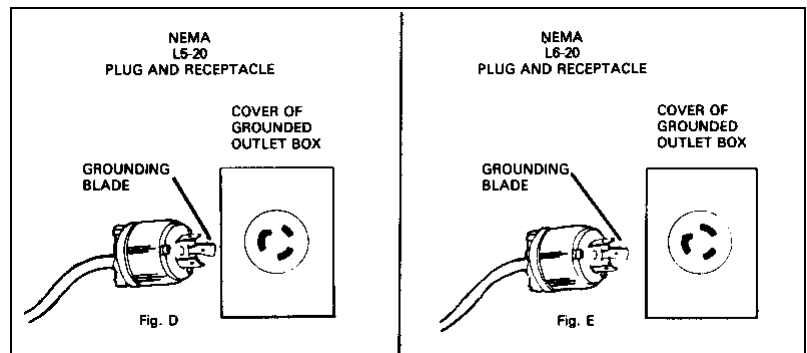

II OPERATION

A. Core Drill Positions

To position the core drill:

1. Roll the drill so that the spindle is positioned over the desired drilling location.
2. Using the leveling screws located on the four corners of the base, level the core drill to insure that the bit will drill a straight, vertical hole.

⇒ **CEILING BRACING** - can be used when the ceiling above the work area is strong enough to provide solid bracing. A length of pipe may be used with the adjustable brace on the top of the drill column to firmly secure the drill against the work piece.

⇒ **ANCHOR BOLTING** - is a method used quite often in both horizontal and vertical drilling. The anchor is secured in the work surface and the core drill is placed over the anchor bolt so that the bolt goes through the hole in the center of the drill base. A nut and washer is used to pull the base down as the nut is screwed onto the anchor bolt.

⇒ **VACUUM HOLD DOWN** - requires that the surface of the intended drilling area be smooth or of an even texture in order to achieve an effective bond to the drilling surface. A large hold down base and vacuum pump are used to fasten the drill to the work surface. Both the pump and large base are available as optional accessories for the drills.

B. Drilling Technique

The performance of any diamond core bit depends heavily on the use of proper drilling technique. Although drilling conditions and materials may vary, following specific guide lines insures faster drilling speeds and longer bit life.

1. Secure the core drill to the work surface so that there is no movement in the drill that would cause the core bit to bind in the hole.
2. Insure that the hole is constantly flushed of abrasive fines by supplying a sufficient flow of water.
3. Slowly lower the bit into the hole so that there is no skidding or lateral movement of the drill. The entire circumference of the core bit should penetrate the drilling surface before additional pressure is applied to the handle.
4. Exert steady downward pressure while drilling. NEVER force the bit into the material!
5. Do not stop the flow of water or rotation of the bit while the core bit is drilling.
6. Check the core bit if the drilling rate decreases noticeably. The slowing penetration rate generally indicates that the bit is in need of reconditioning.

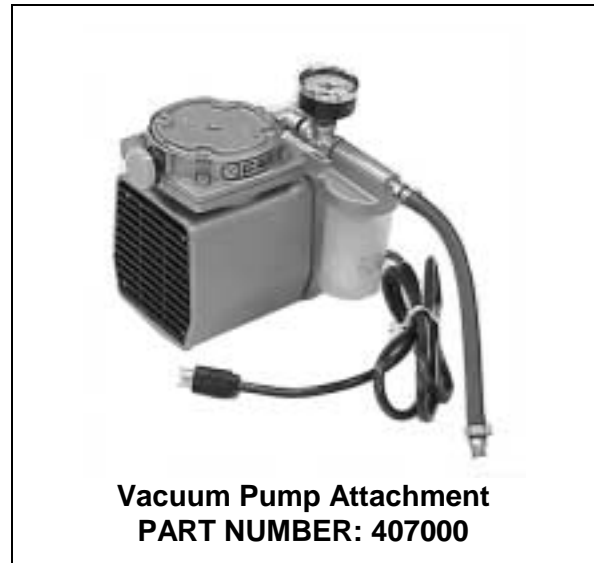

II OPERATION

C. Vacuum Hold Down Operation

The vacuum hold down base and pump work together to seal the drill to the work surface. The vacuum pump requires 115 volt electrical supply. A 115 volt accessory outlet located on the switch box is used to supply power to the vacuum pump. One outlet is consistently supplied with power so that turning the motor off does not turn off the vacuum pump and release the drill from the work surface.

1. Mount the column and carriage in the large vacuum hold down base.
2. Connect the vacuum pump to the vacuum base.
3. Wet the work area in order to achieve an effective seal.
4. Connect the vacuum pump cord into the top outlet of the receptacle in the switch box above the motor. This will start the pump and create a seal between the base and the work surface.
5. Adjust the leveling screws so that the core drill is level and resting lightly on the vacuum seal.
6. Plug the vacuum pump cord into the live outlet of the receptacle in the switch box. This will start the pump and create a seal between the base and the work surface.
7. Adjust the leveling screws so that the base is snug against the work surface. NOTE: (Excessive tightening of the leveling screws will break the seal between the base and the work surface).
8. To turn the vacuum pump off, unplug the power cord.

D. Water Collector Operation

The water collector unit (Part Number 402034) is designed to work with any core drill. It can be used with any diameter core bit up to and including ten inch. The unit consists of a tear dropped shaped ring with a rubber seal, a 115 volt electric water pump and a drainage hose.

1. Place the pump in the small end of the tear-drop ring. Center the large area of the ring over the area to be drilled.
2. Run the drainage hose from the pump to a drainage barrel and secure the hose to the barrel with the hose hook.
3. PROPERLY GROUND THE PUMP, then plug it into the top outlet of the core drill switch box.
4. Turn the pump off by unplugging the pump power cord at the cord drill switch box.

III. MAINTENANCE AND COMPONENT DESCRIPTION

A. Motor Specifications Dewalt

Specifications

MFR	MODEL	VOLT	AMP	MOTOR RPM		BIT CAPACITY IN	
				LOW GEAR	HIGH GEAR	LOW GEAR	HIGH GEAR
DEWALT	DW194	120	20	350	900	5"-9"	2"-5"

*Refer to motor owners manual supplied with drill for required motor maintenance.

The Dewalt motor is designed to operate with two speeds. Changing speeds is accomplished by using the speed shift lever built into the gear case of the unit.

Changing the rpm of the motor is accomplished as follows:

1. Loosen the shift lever locking knob.
(1/4 turn CCW)
2. Move the shift lever until the clutch teeth are fully engaged. Moving the lever toward the motor engages the LOW rpm while moving the lever toward the spindle engages the HIGH rpm.
3. Retighten the shift lever locking knob.
NOTE: use a wrench or pliers to tighten the locking knob, hand tightening should be sufficient under normal conditions.

Changing the rpm is easily accomplished while the motor is running. Attempting to shift with the motor off may require turning the spindle by hand to engage the clutch.

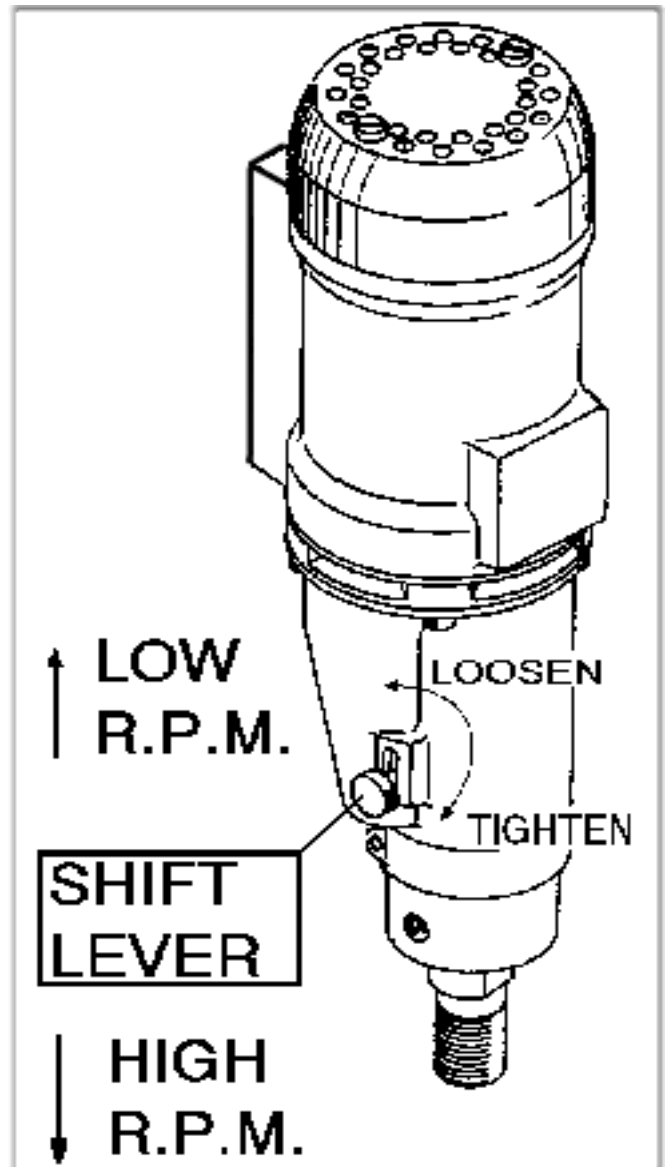

III. MAINTENANCE AND COMPONENT DESCRIPTION

A. Motor Specifications (MILWAUKEE 4035 & 4094) Specifications

MFR	MODEL	VOLT	AMP	MOTOR RPM		BIT CAPACITY IN	
				LOW GEAR	HIGH GEAR	LOW GEAR	HIGH GEAR
MILW	4097-20	120	15.0	500	1000	3"-5"	3"-5"
MILW	4096	120	20	450	900	6" - 10"	2" - 6"

*Refer to motor owners manual supplied with drill for required motor maintenance.

The Milwaukee electric motors are designed to operate at two speeds. The speed changes are easily made by means of a conveniently located shift lever which transfers the drive gear from low to high rpm.

Motors are equipped with clutch.

ALWAYS TURN OFF SWITCH AND SHIFT WHILE THE MOTOR IS COASTING TO A STOP!

NEVER SHIFT AT FULL RPM OR WHEN THE MOTOR IS UNDER LOAD OR STOPPED!!

To change speeds on the Milwaukee motor the procedure is as follows:

1. Turn off switch, as the motor is coasting to a stop, rotate the shift knob clockwise to go from the HIGH to LOW speed.
2. Turn off switch, as the motor is coasting to a stop rotate the shift knob counter-clockwise to go from LOW to HIGH rpm.

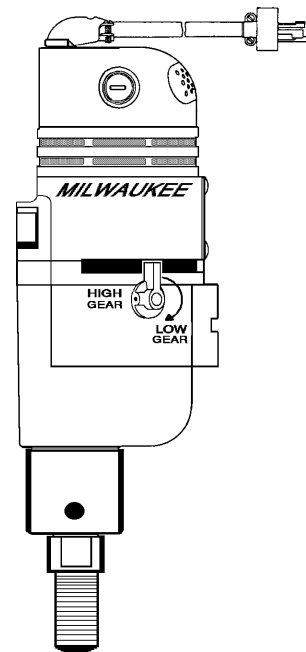

III. MAINTENANCE AND COMPONENT DESCRIPTION

The vacuum pump is used with the large vacuum hold down base to secure the core drill on smooth evenly textured surfaces.

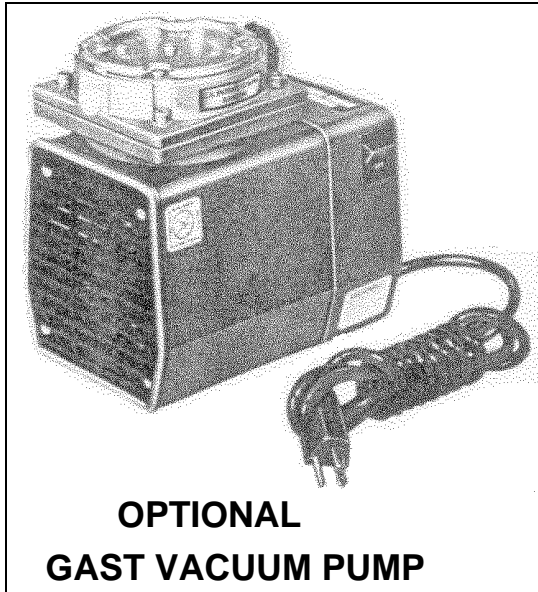

The pump is powered by a 115 volt, 4.2 amp, 60 hertz electric motor. The power cord of the pump is plugged into the **live** outlet of the receptacle in the switch box of the core drill. The switch box on the drill allows the motor on the drilling unit to be turned on and off without shutting down the vacuum pump and breaking the seal between the drill base and the work surface.

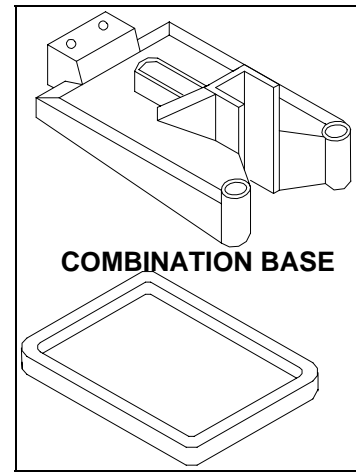

The required maintenance procedure for the vacuum pump is listed in the "**Parts List and Operating and Maintenance Instructions**" pamphlet. Parts for the vacuum pump are available from local distributors of Gast products. A listing of Gast distributors is available in this drill manual and in the vacuum pump pamphlet.

D. Leveling Screws

The four leveling screws on the base should be cleaned with a mild solvent and lubricated with a lightweight machine oil each time the machine is used. Allowing the slurry to accumulate on the threads may cause damage to the threads in the base.

E. Carriage

The carriage or head assembly should be cleaned and lubed with a lightweight machine oil each time the machine is put away. Allowing slurry to build on the column and inside the carriage will prematurely wear the pinion gear and gibs.

III. MAINTENANCE AND COMPONENT DESCRIPTION

F. Gibs

The gibs are brass wear shims used on the inside of the carriage which allow the carriage to slide freely and rigidly on the column. The gibs require periodic replacement. Replacing the gibs is necessary when the carriage is no longer rigid on the column. Keeping the column free of excess debris and burrs will maximize the service life of the gibs.

G. Motor Spindle

The motor spindle on all core drill motors is equipped with 1-1/4"-7 thread dimensions. The end adapter of the core bit is also threaded 1-1/4"-7 on core bits of 2 inches and larger diameter. Core bits with a diameter less than 1-5/8 inches have 5/8"-11 threads and require the use of an adapter.

The motor spindle maintenance should be performed each time the machine is stored for the day. Leaving the core bit on the motor spindle may cause the threads on the spindle to rust making removal of the core bit very difficult. After removing the core bit check the threads for any nicks or burrs. The spindle should then be cleaned with a mild solvent and lubricated with a lightweight machine oil.

Removing the core bit from the motor spindle by turning the core bit barrel is not recommended. The core bit barrel may break the weld between the adapter plate and barrel if excessive side pressure is applied. The best results are achieved using two wrenches. One of the wrenches placed on the machined flats on the motor spindle and the other wrench on the core bit end adapter.

H. Vacuum Seal

The vacuum seal is the sponge rubber gasket which lines the bottom of the large vacuum base. The material prevents air from entering the area under the base. Thus allowing the vacuum to pull against the work surface. In order for the seal to work properly the seal material must remain pliable and in one piece with no gaps or inconsistencies on the surface. The vacuum seal should be rinsed at the completion of each operation. Allowing the slurry to accumulate on the gasket will cause the material to deteriorate prematurely. The vacuum seal should be checked on a regular basis and replaced if it has been damaged or started to deteriorate.

III. MAINTENANCE AND COMPONENT DESCRIPTION

I. Electrical Wiring Diagram

BEFORE CONNECTING DRILL TO THE POWER SOURCE, MAKE SURE THE VOLTAGE AND CYCLES SHOWN ON THE NAME PLATE AGREE WITH THE AVAILABLE ELECTRICAL SUPPLY!

ALWAYS PROPERLY GROUND THE CORE DRILL!

NEVER CONNECT THE GREEN WIRE TO A LIVE TERMINAL!

INTERNAL WIRING DIAGRAM

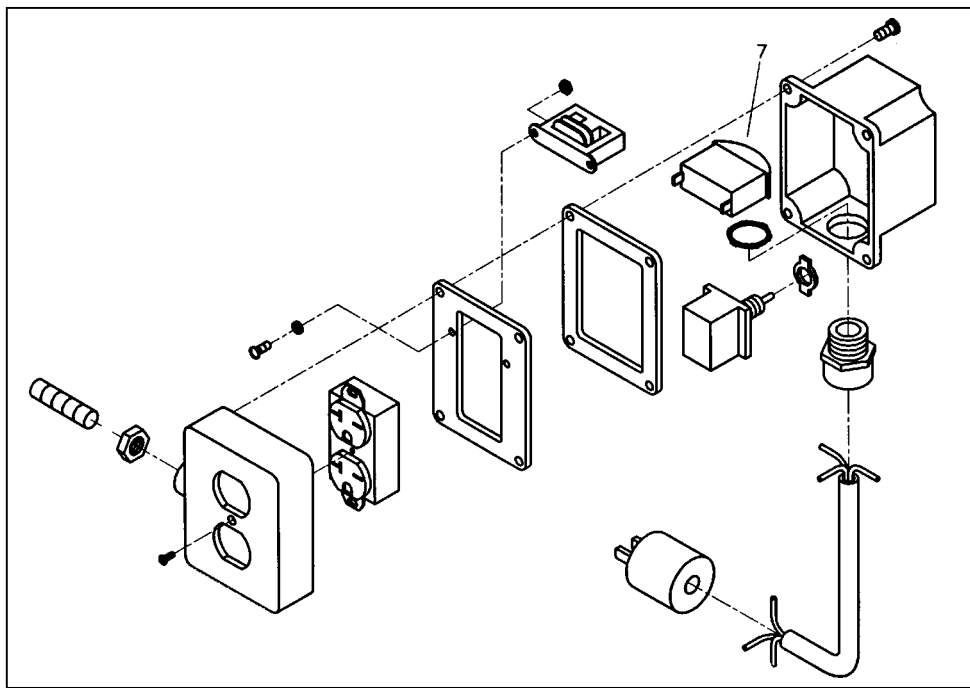
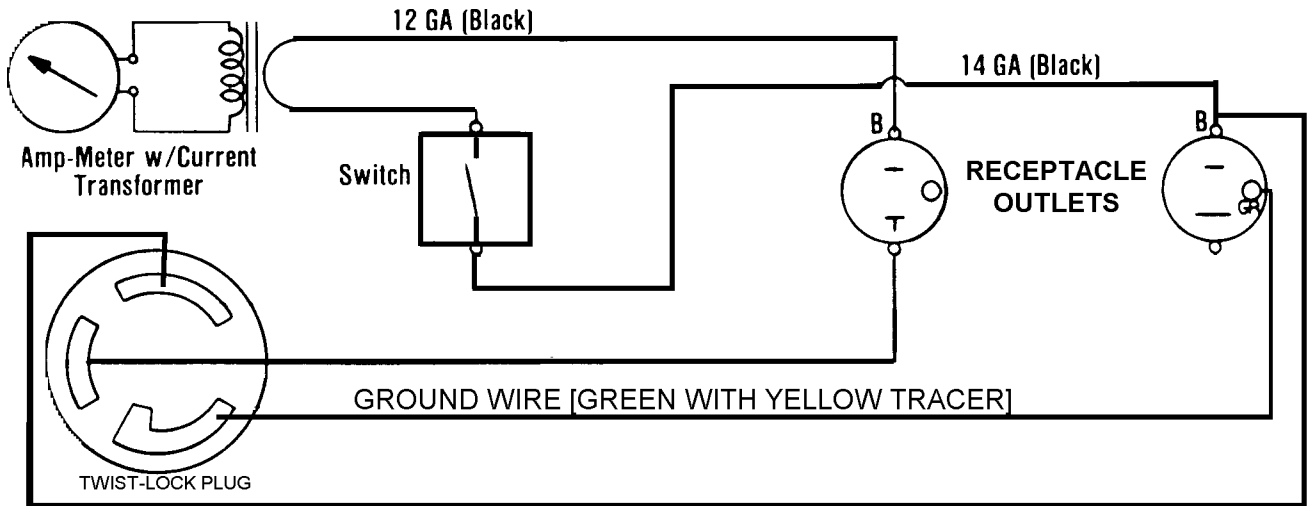

IV. PARTS LIST SECTION

A. Ordering Information

1. List model number of machine.

2. List part number and description of part (not item number).
3. Wherever alternate parts are shown due to product improvement, inspect the part you have and provide additional description as necessary.
4. Specify mode of shipping desired, such as, parcel post, truck, air freight, U.P.S., best way, etc.

B. Optional Accessories

1. **Vacuum Hold Down: Part Number 407000** Provides a means of securing the core drill on smooth evenly textured surfaces without using anchors.
2. **Water Collector Kit: Part Number 402034** covers the excess water used during the drilling operation and pumps it into a drum. The ring is used to limit the amount of area that is exposed to water. The ring is best used in areas where the surface texture is smooth and even.
3. **Shaft Couplings:** The couplings are used as adapters which decrease or increase the spindle diameter and thread dimension.

Part Number	Spindle Thread	Adapter Thread
400145	1/2"--20	5/8"--11
400146	5/8"--11	1/2"--20
400147	5/8"--11	1-1/4"--7
400148	1-1/4"--7	5/8"--11

4. **Shaft Extensions:** Extend the depth to which a core bit will drill when the carriage travel has reached the maximum travel distance of the column.

Part Number	Spindle Thread	Length
402754	1-1/4"--7	9"
402755	1-1/4"--7	3.5"
402756	1-1/4"--7	12"
402757	5/8"--11	12"
402758	5/8"--11	6"
402759	5/8"--11	3"

5. **Motor Spacer Plate Kit: Part Number: 407012** Moves the motor away from the column so that the drill will accept up to a fourteen inch bit.

ASSEMBLY DRAWINGS

DM 450 & 500 CORE DRILLS



IV. PARTS LIST SECTION

D. Service parts list for DM Core Drills.

Drill Base And Column

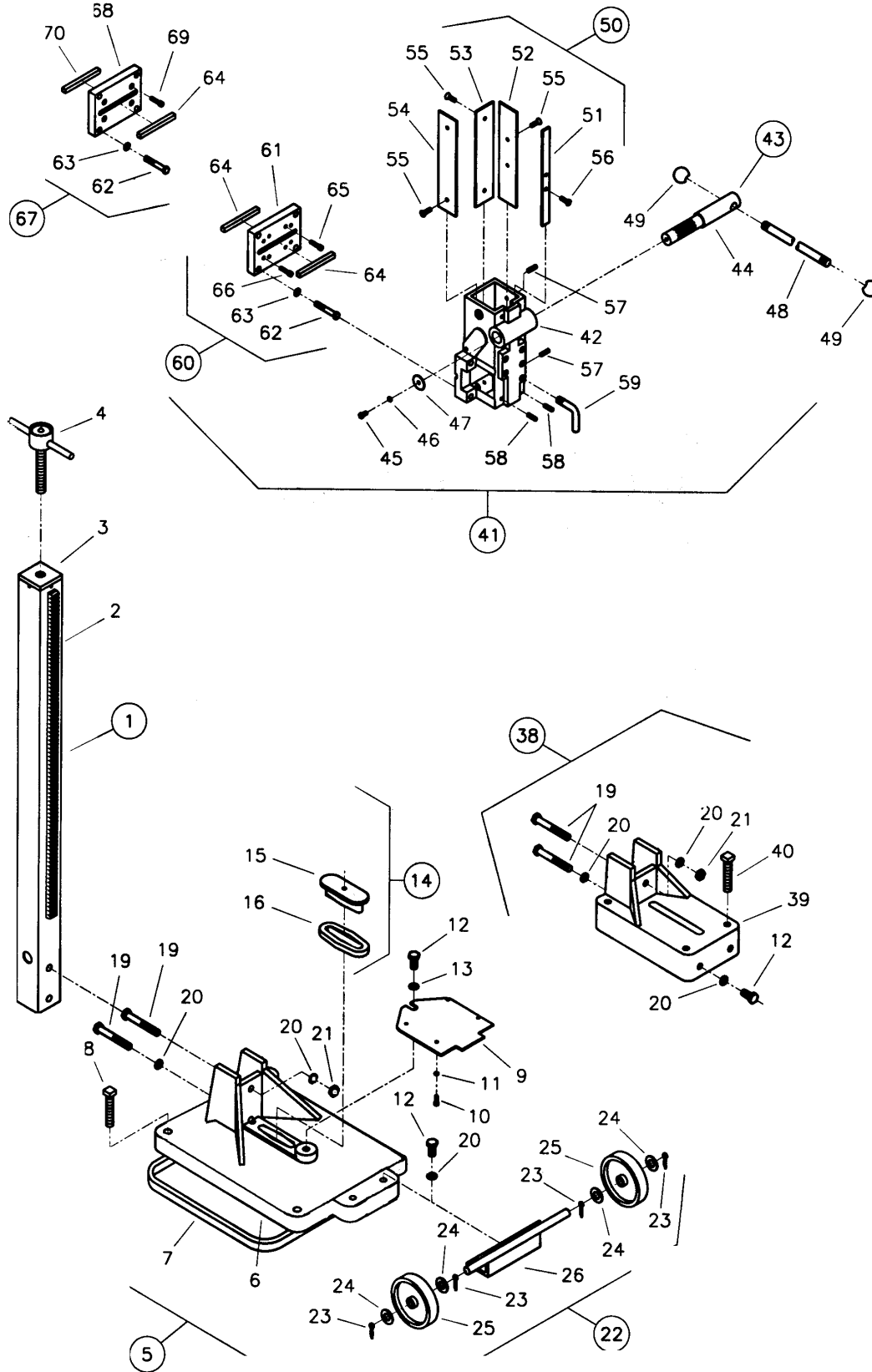

Drill Base And Column

Item	Part #	Qty	Description	Item	Part #	Qty	Description
1	407001	1	Column 2-1/2" SQ x 42" (Includes 2 & 3)	44	407024	1	Pinion Gear Only
2	407002	1	Gear Rack Only 32"	45	8041002	1	Scr ¼-20 x ½" Hex Head Cap
3	407003	1	Col. Top With Pins	46	8177010	1	Washer ¼" Lock
4	407004	1	Ceiling Jack	47	407025	1	Washer ¼" ID x 1-1/4 OD Fender
5	407005	1	Comb. Base Assy. (Includes 6-26)	48	407026	1	Handle
6	407006	1	Comb. Base Only	49	407027	2	Handle Knob
7	407007	1	Vacuum Gasket	50	407028	1	Shim Assy (Includes 51-56)
8	8041145	4	Scr 5/8-11 x3 Hex Head Cap	51	407029	2	Adj Shim Brass 1/8 x 5/8 x 8-7/8
9	407008	1	Vacuum Mount	52	407030	1	Adj Shim Brass 1/8 x 1-1/2 x 9
10	8058134	4	Scr #10-32 x 5/8" Cap	53	407031	1	Non-Adj Shim 1/8 x 1-1/2 x 9
11	8172005	4	Washer #10 USS Flat	54	407032	1	Non-Adj Shim 1/8 x 1-1/2 x 9
12	8041094	3	Scr ½-13 x1" Hex Head Cap	55	407033	6	Scr ¼-20 x 5/8" Flat Head Brass
13	8172011	1	Washer ½ USS	56	407034	4	Scr ¼-20 x 1" Flat Head Brass
14	407009	1	Slot Cap (Includes 15-16)	57	407035	2	Scr ¼-20 x ½" Set
15	407010	1	Slot Cap Only	58	407036	4	Scr ¼-20 x 3/8" Set
16	407011	1	Slot Cap Gasket	59	407037	1	Carriage Lock ½-13
19	8041104	2	Scr ½-13 x 3-1/2" Hex Head Cap	60	407038	1	Motor Mount Assy (Includes 61-66)
20	8177014	4	Washer ½ Lock	61	407039	1	Motor Mount Plate
21	8143005	1	Nut ½-13 Jam	62	407040	4	Scr 3/8-16 x 2-1/4
22	407013	1	Wheel Assembly (Includes 23-26)	63	8177012	4	Washer 3/8" Lock
23	407014	4	Cotter Pin 3/32" x 1"	64	407041	2	Key 3/8"SQ x 4"
24	8172013	4	Washer 5/8" Flat	65	407042	4	Scr ¼-28 x 1 Dewalt
25	407015	2	Wheel 6"	66	407043	4	Scr ¼-20 x 1 Milw.
26	407016	1	Wheel Mount Bracket				
30	8041106	1	Scr 1-8 x 4-3/4" Hex Head Cap	-NA-	407012	1	Spacer Block With Hardware
31	407017	1	Nut 1-8 Jam				
38	407018	1	Anchor Base (Small) Assy (Includes 12,19-26,39, & 40)				
39	407019	1	Anchor Base Only				
40	407020	4	Scr ½-13 x 4" Hex Head Cap				
41	407021	1	Carriage Assy (Includes 42-66)				
42	407022	1	Carriage Only				
43	407023	1	Pinion Gear Assy (includes 44-47)				

Vacuum Base Assembly

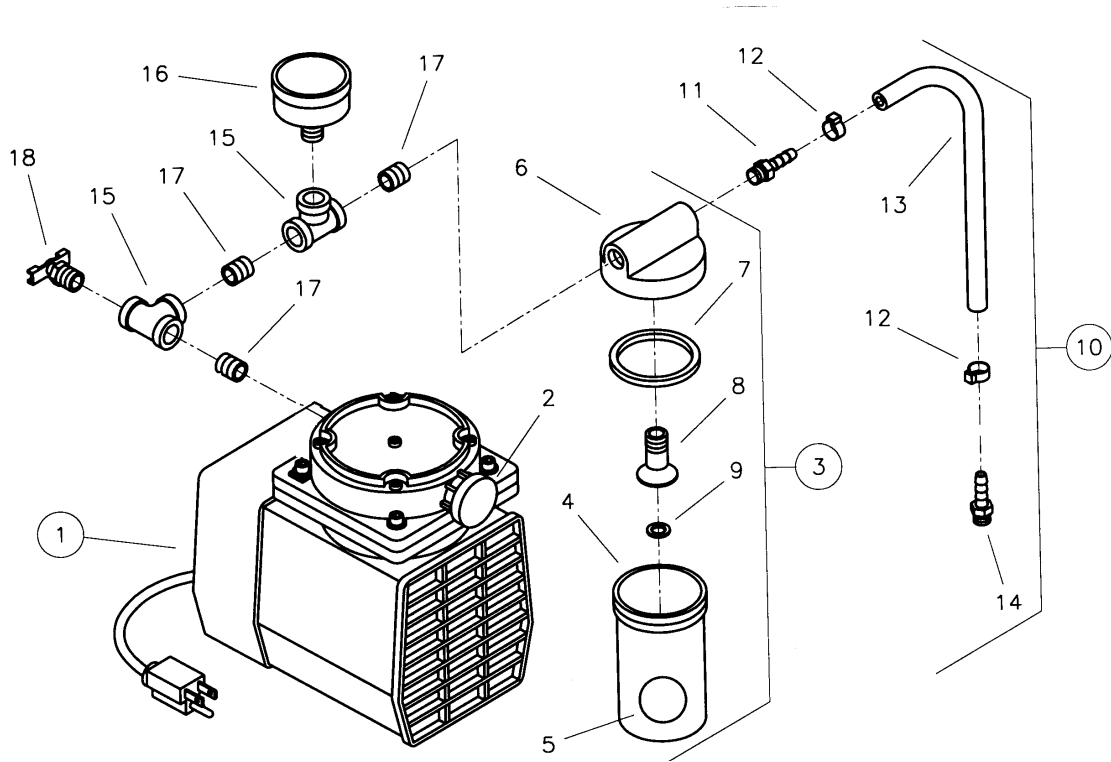

Item	Part #	Qty	Description
-NA-	407000	1	Vacuum Pump Assy 110-volt (Includes 1-18)
1	407044	1	Vacuum Pump, 110-volt (Includes 2-9)
2	407045	1	Muffer
3	403076	1	Water Trap Jar Assy (Includes 4-9)
4	407047	1	Water Trap Jar
5	407048	1	Float Ball
6	407049	1	Water Trap Top
7	407050	1	Water Jar Gasket
8	407051	1	Brass Funnel Fitting
9	407052	1	O-Ring
10	407053	1	Hose Assy 9-1/4" Long (Includes 11-14)
11	407054	1	1/4" Hose Barb To 1/4" Male Pipe
12	407055	2	Hose Clamp 1/2" Pinch On
13	407056	1	Hose 1/4" ID x 9-1/4" Long
14	407057	1	Fitting 1/4" Hose Barb To 1/8" Male Pipe
15	407058	2	Pipe Tee 1/4" NPT
16	407059	1	Vacuum Gauge
17	407060	3	Close Nipple 1/4" NPT
18	407061	1	Air Petcock

Electrical Box Assembly

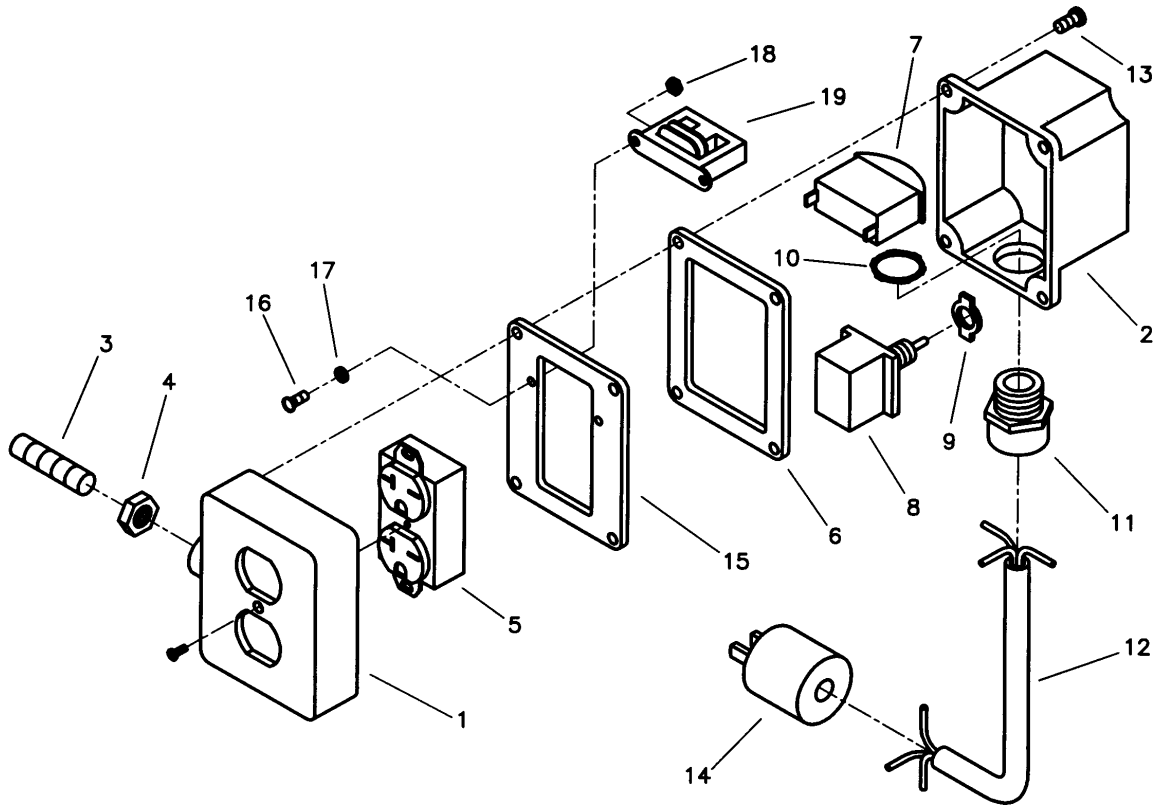

Item	Part #	Qty	Description
-NA-	407062	1	Electrical Box Assembly 110-volt (Includes 1-19)
1	407063	1	Switch Box
2	407064	1	Switch Base
3	407065	1	Stud ½"-13 x 2"
4	407066	1	Jam Nut ½-13
5	407067	1	Receptacle 110-volt
6	407068	1	Spacer Gasket
7	407069	1	Amp Meter 110-volt
8	407070	1	Toggle Switch 20-Amp
9	407071	1	On-Off Plate
10	407072	1	Sealing Lock Nut ¾"
11	407073	1	Cord Connector ¾"
12	407074	1	Line Cord 110-volt
13	407075	4	Scr #10-24 x 7/8" Machine Round Head
14	407076	1	Plug 30 Amp
15	407077	1	Mount Plate
16	407078	2	Scr #6-32 x ½" Machine Round Head
17	407079	2	Washer #6 Lock
18	407080	2	Nut #6-32 Hex
19	407081	1	Transformer 110-volt

I. OPERATING AND MAINTENANCE INSTRUCTIONS (MODEL DOA-V185A-AA)

Do not at any time lubricate any of the parts with oil, grease, or petroleum products nor clean with acids, caustics or chlorinated solvents. Be very careful to keep the diaphragm from contracting any petroleum product or hydrocarbons. It can affect the service life of the pump.

Danger: To prevent explosive hazard, Do NOT pump combustible liquids or vapors with these units. Personal Injury and/or Property Damage would result.

To replace the diaphragm, remove the socket cap screws from the head of the pump. The diaphragm is held in place by two Phillips head screws. Remove screws, retainer plate, and the diaphragm. The diaphragm will fit in any position on the connecting rod. Replace the plate and the two Phillips head screws. Torque to 30 inch-pounds on DOA and DAA. torque to 12 inch-pounds on MOA and MAA.

Caution: Do not raise any burrs or nicks on the heads of these screws. These burrs could cause damage to the inlet valve.

For replacing the inlet and outlet valve, remove the slotted machine screw that holds each valve in place. The stainless steel inlet and outlet valves are interchangeable.* Clean them with water. When replacing the outlet valve, place the new valve in location and note there is a retaining bar near the machine screw hole. This retaining bar holds the valve in position. When replacing the inlet valve, note that the valve holder is marked with an X in one corner. This X should be in the lower right hand corner toward the inlet of the air chamber. Replace the head and tighten the socket head screws to 90-100 inch-pounds of torque on DOA and DAA Torque to 30 Inch-pounds on MOA and MAA. *DOA and DAA models only.

WARNING-The motor may be thermally protected and can automatically restart when the overload resets. Always disconnect power source before servicing. Personal Injury and/or Property Damage could result.

Do not attempt to replace the connecting rod or motor bearings. If after cleaning the unit and/or installing a new Service Kit, the unit still does not operate properly, contact your representative, the factory, or return the pump to one of the GAST authorized Service Centers.

IF YOUR PUMP IS EQUIPPED WITH PLASTIC PLUGS IN THE EXHAUST AND/OR INTAKE PORTS, REMOVE BEFORE STARTING UNIT.

WIRING INFORMATION

For any D.C. unit-red lead goes to positive side of power source.

For any permanent split capacitor motor which has four leads(4) leads is as follows:
Brown leads to capacitor.

Black leads to Power Source.

For any permanent split capacitor for DOA & DAA motor which has (3) leads is as follows: Figure 3

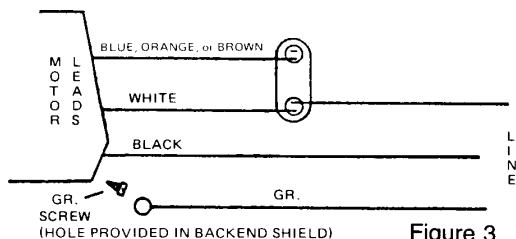
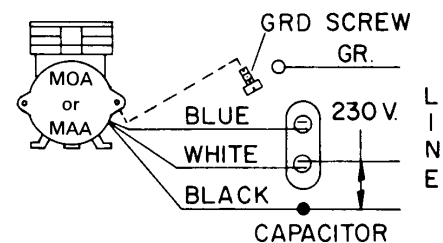
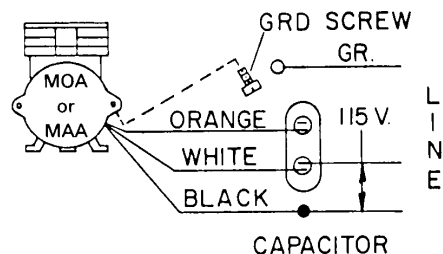

DO NOT ATTEMPT AT ANY TIME TO REMOVE THE CONNECTING ROD OR COMPLETELY DISASSEMBLE THE PUMP. IF IT DOES NOT GIVE YOU THE PROPER SERVICE EVEN AFTER INSTALLING A NEW SERVICE KIT, PLEASE RETURN IT TO ONE OF THE AUTHORIZED GAST SERVICE CENTERS LISTED IN THE SERVICE CENTER PAGES.

DeWalt

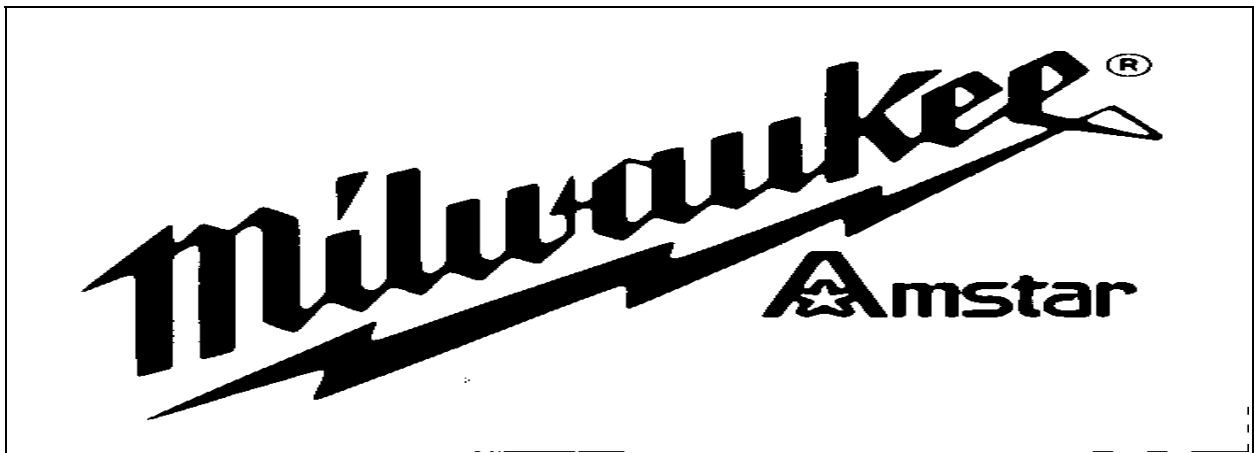



AUTHORIZED SERVICE CENTERS

DeWalt

ALABAMA

Power Tools Services Inc.
1113 4th Avenue South
Birmingham, Alabama 35233

ALABAMA

Smith Power Tool Inc.
2503 Commercial Park Drive
Mobile, Alabama 36636

ALASKA

Aero Services Inc.
203 Post Road
PO Box 1554
Anchorage, Alaska 99701

ALASKA

D & D Industries
3960 S. Cushman
Fairbanks, Alaska 99701

ARIZONA

Glenn's Tool Service
4036 North 13th Way East
Phoenix, Arizona 85014

ARIZONA

Electric Motor Company
1028 East Broadway
Tucson, Arizona 85014

ARKANSAS

Henninger, Inc.
1206 South Main Street
Little Rock, Arkansas 72202

CALIFORNIA

Blackstone Electric Motor Shop
1251 Blackstone Avenue
Fresno, California 93703

CALIFORNIA

Sacramento Industrial Electric Co.
6325 Elvas Avenue
Sacramento, California 93703

CALIFORNIA

Star Tool & Supply Company
3941 Main Street
San Diego, California 92110

CALIFORNIA

Precision Mechanical
260 Commercial Street
San Jose, California 95112

CONNECTICUT

Portable Power Tool Repair Company
447 Arch Street, Rear
New Berlin, Connecticut 06051

FLORIDA

Florida Electric Motor Service
1128 Atlanta Avenue
Orlando, Florida 32806

FLORIDA

Electrical Repair Company
1228 East Cass Street
Tampa, Florida 33602

FLORIDA

Holland Repair
6410 Norwood Avenue
Jacksonville, Florida 32208

HAWAII

Central Service & Sales Inc.
687 Auahi Street
Honolulu, Hawaii 96813

IDAHO

K.C. Supply Company
814 North Manville Street
Boise, Idaho 83704

IDAHO

Wade Tool Service
513 Thain Road
Lewiston, Idaho 83501

ILLINOIS

Couch & Heyle
2500 North Main Street
East Peoria, Illinois 61611

INDIANA

Anderson Brothers Tool Repair
3531 Southeastern Avenue
Indianapolis, Indiana 46203

INDIANA

Ram Supply Company Inc.
1301 West Franklin Street
Evansville, Illinois 47701

IOWA

Jim's Appliance Service
901 Ninth Street, S.W.
Cedar Rapids, Iowa 52404

AUTHORIZED SERVICE CENTERS

DEWALT

IOWA

Five Cities Tool Service Inc.
921 Ninth Street, S.W.
Davenport, Iowa 52802

IOWA

Electrical Engineering & Equipment Company
1808 Delaware Street
Des Moines, Iowa 50317

KANSAS

B & B Electric
332 Lulu
Wichita, Kansas 67211

KENTUCKY

City Electric Motor Shop
492 East High Street
Lexington, Kentucky 40217

KENTUCKY

Tool Repair Service
1200 Goss Avenue
Louisville, Kentucky 40508

LOUISIANA

Baton Rouge Electric Motor Service
5409 Evangeline Street
Baton Rouge, Louisiana 70805

LOUISIANA

Beerman Precision Machine Works Inc.
2021 Thalia St. / PO Box 53432
New Orleans, Louisiana 70150

MARYLAND

Roland Electric Company
330 West 23rd Street
Baltimore, Maryland 21211

MARYLAND

Turner Electric Company
201 Ethan Allen Avenue
Takoma Park, Maryland 20012

MASSACHUSETTS

Reliance Electric Service Company
573 South Canal Street
Holyoke, Massachusetts 01040

MICHIGAN

J.T. Hoeksema Company
2499 28th Street, S.W.
Grand Rapids, Michigan 49509

MINNESOTA

Horvick Electric Motor Company
303-307 Main Avenue
Moorhead, Minnesota 56560

MISSISSIPPI

Flannigan Electric Company, Inc.
328 Oakdale Street
Jackson, Mississippi 39204

MISSOURI

P.M. Electric Company, Inc.
5280 Flyer Avenue
St. Louis, Missouri 63139

MONTANA

Electro Service Center
1919 Harve
Missoula, Montana 59801

MONTANA

Mosen Electric Company
326 3rd Avenue, South
Great Falls, Montana 59801

MONTANA

Ted's Electric Service
902 Howard Avenue
Billings, Montana 59102

NEBRASKA

Flohr Electric Service, Inc.
2516 Cuming Street
Omaha, Nebraska 68131

NEW MEXICO

Telco Electric Inc.
2906 4th Street
Albuquerque, New Mexico 87170

NEW YORK

Richter Electric Service, Inc.
1559 Niagara Street
Buffalo, New York 14213

NEW YORK

Barrett Electric Service, Inc.
112 Henry Street
Schenectady, New York 12304

NEW YORK

Ramsing Electric Service Company
125 Charles Avenue (Syracuse)
Solvay, New York 13209

AUTHORIZED SERVICE CENTERS

DEWALT

NORTH CAROLINA

Portable Tool Service
3209 Cullman Avenue
Charlotte, North Carolina 28206

OHIO

Cincinnati Electrical Repair Company
2023 Elm Street
Cincinnati, Ohio 45210

OHIO

Columbus Electrical Works Company
777 North Fourth Street
Columbus, Ohio 45210

OHIO

M & R Electric Motor Service, Inc.
1516 East Fifth Street
Dayton, Ohio 45210

OKLAHOMA

Capitol Electric Motor Repair Inc.
2215 Southwest 11th
Oklahoma City, Oklahoma 74120

OKLAHOMA

Hammond Electric Company
1510 East Third Street
Tulsa, Oklahoma 74120

OREGON

Keith's Electric Motor Service
678 Olive Street
Eugene, Oregon 97401

OREGON

Walker Electric Works
206 Northwest 10th Avenue
Portland, Oregon 97209

PENNSYLVANIA

Power Tool Service [P.T.S.]
38 West Allen Street
Mechanicsburg, Pennsylvania 17055

PENNSYLVANNIA

Snyder Electric Company
1500 Chateau Street
Pittsburgh, Pennsylvania 15233

PUERTO RICO

Power Tool Repair Center
Duarte 166
Hato Rey, Puerto Rico 00917

RHODE ISLAND

Babine Electric Service Inc.
315 Jefferson Boulevard
Warwick, Rhode Island 02888

SOUTH CAROLINA

Mann Electric Repair Company
2909 Main Street
Columbia, South Carolina

SOUTH CAROLINA

Delta Industrial Electric Company, Inc.
1906 Meeting Street {PO Box 622}
Charleston, South Carolina 29402

TENNESSEE

Electric Service Company
3914 McCalla Avenue
Knoxville, Tennessee 37914

TENNESSEE

Southern Electric Company
812 Porter Street
Memphis, Tennessee

TENNESSEE

Allied Electric Motor Company, Inc.
939 - 4th Avenue South
Nashville, Tennessee 37210

TENNESSEE

Dixie Industrial Service Inc.
2108 East Main Street
Chattanooga, Tennessee 37210

TEXAS

Electric Motor Sales & Service
1514 East Commerce Street
San Antonio, Texas 78205

TEXAS

G.E. Jones Electric Company, Inc.
212 North Polk
Amarillo, Texas 78722

TEXAS

Hamilton Electric Works, Inc.
3800 Airport Boulevard
Austin, Texas 78722

TEXAS

Tool House Inc.
1711 Texas Avenue
Lubbock, Texas 79401

AUTHORIZED SERVICE CENTERS

DEWALT

UTAH

Diamond Electric Motor Service
1465 South Second West Street
Salt Lake City, Utah 84104

VERMONT

Burlington Rent-All
340 Dorset Street
Burlington, Vermont 05401

VIRGINIA

Bryan Electric Company
424 West 25th Street
Norfolk, Virginia 23517

VIRGINIA

Lloyd Electric Company Inc.
521s West Salem Avenue
Roanoke, Virginia 24016

VIRGINIA

Wingfield & Hundley, Inc.
2403 East Franklin Street
Richmond, Virginia 23205

Washington

K & N Electric Motors, Inc.
217 West Cataldo
Spokane, Washington 98902

WISCONSIN

Jet Power Tool Repair, Inc.
970 Jonathon Drive
Madison, Wisconsin 53717

WISCONSIN

Power Tool Service Company
310 North Webster Avenue
Green Bay, Wisconsin 54301

FACTORY SERVICE CENTERS

MILWAUKEE POWER TOOL

ANAHEIM

1130 North Magnolia Street
Anaheim, California 92801
Phone: 714 827-3970
213 624-7615
213 860-0349

ATLANTA

2381 John Glenn Drive
Suite 102
Chamblee, Georgia 30341
Phone: 404 455-7300

BOSTON

143 California Street
Newton, Massachusetts 02158
Phone: 617 244-4483

CHICAGO

7315 North Monticello Avenue
Skokie, Illinois 60076
Phone: 312 539-9173

CLEVELAND

7600 Wall Street
Cleveland, Ohio 44125
Phone: 216 524-8040

DALLAS

7205 Envoy Court
Dallas, Texas 75247
Phone: 214 637-4820

DENVER

2620 West 2nd Street
Denver, Colorado 80290
Phone: 303 922-1163

DETROIT

999 Troy Court
Troy, Michigan 48084
Phone: 313 585-8252

HOUSTON

4801 Katy Freeway
Houston, Texas 77007
Phone: 713 861-4671

KANSAS CITY

1506 Topping
Kansas City Missouri 64120
Phone: 816 241-7300

MIAMI

8101 North West 33rd Street
Miami, Florida 33122
Phone: 305 592-0442

MILWAUKEE

4057 North 128th Street
Brookfield, Wisconsin 53005
Phone: 414 781-0951

MINNEAPOLIS

2200 West 94th Street
Bloomington, Minnesota 55431
Phone 612 884-7258

NEW YORK

27-07 Brooklyn Queens Expressway W.
Woodside, New York 11377
Phone: NY 212 721-5151
NJ 201 622-7752

PHILADELPHIA

388 Reed Road
PO Box 224
Broomall, Pennsylvania 19008
Phone: 215 544-5544
Philadelphia: 215 528-6771

SAN FRANCISCO

329 Littlefield Avenue
South San Francisco, California 94080
Phone: 415 583-8484
San Francisco: 415 761-2851

SEATTLE

503 South Michigan Street
PO Box 80346
Seattle, Washington 98108
Phone: 206 762-8430

FACTORY SERVICE CENTERS**GAST**

BRENNER-FIELD & ASSOCIATES

13824 Bentley Place
Cerritos, California 90701
[213] 404-2721

GAST MANUUFACTURING CORPORATION

2550 Meadowbrook Road
Benton Harbor, Michigan 49022
[616] 926-6171

GAST MANUUFACTURING CORPORATION

505 Washington Avenue
Carlstadt, NJ 07072
[201] 933-8484

WAINBEE, LIMITED

121 City View Drive
Rexdale, Ontario, Canada M9W 5A9
[416] 243-1900

WAINBEE LIMITED

215 Brunswick Boulevard
Pointe Claire, Montreal, Canada H9R 4R7
[514] 697-8810

GAST MANUFACTURING COMPANY., LTD

Halifax Road, Cressex Estate
High Wycombe, Bucks HP12 3SN
England
High Wycombe 23571

I. Machine Service Log

Service Log

MODEL: _____ **Serial #:** _____

Norton Construction Products
PO Box 2898, Gainesville, Georgia 30503-2898
Phone: 800-554-8003 or 770-967-3954
(8:00 A.M. to 7:00 P.M. Eastern Time)
Fax: 800-443-1092 or 770-967-4287

elipper

WARNING

Some dust created by power sanding, sawing, grinding, drilling, and other construction activities contains chemicals known to cause cancer, birth defects or other reproductive harm. Some examples of these chemicals are:

- Lead from lead-based paints,
- Crystalline silica from bricks and cement and other masonry products, and
- Arsenic and chromium from chemically-treated lumber.

Your risk from these exposures varies, depending on how often you do this type of work. To reduce your exposure to these chemicals: work in a well ventilated area, and work with approved safety equipment, such as those dust masks that are specially designed to filter out microscopic particles.