



**User Instruction Manual for:**

Rescue Ladder System

(Model Numbers: Ladder - 8516294,  
Hanging Plate Bracket - 8516316)

## **USER INSTRUCTION MANUAL RESCUE LADDER SYSTEM**

*This manual is intended to meet the Manufacturer's Instructions as required by the standards and should be used as part of an employee training program as required by OSHA.*

**WARNING:** *This product is part of a rescue and positioning system. This manual must be provided to the user/rescuer. The user must read and follow the manufacturer's instructions for each component part of the complete system. These instructions must be provided to the user of this equipment. The user/rescuer must read and understand these instructions or have them explained to them before using this equipment. Manufacturer's instructions must be followed for proper use and maintenance of this product. Alterations or misuse of this product or failure to follow instructions may result in serious injury or death.*

**IMPORTANT:** *If you have any questions on the use, care, application, or suitability for use of this safety equipment, contact Capital Safety immediately.*

### **DESCRIPTION**

**8516294 - RESCUE LADDER:**

1-3/4 inch polyester web, aluminum brackets.

**8516316 - HANGING PLATE BRACKET:**

Aluminum plate attached with wire rope extensions.

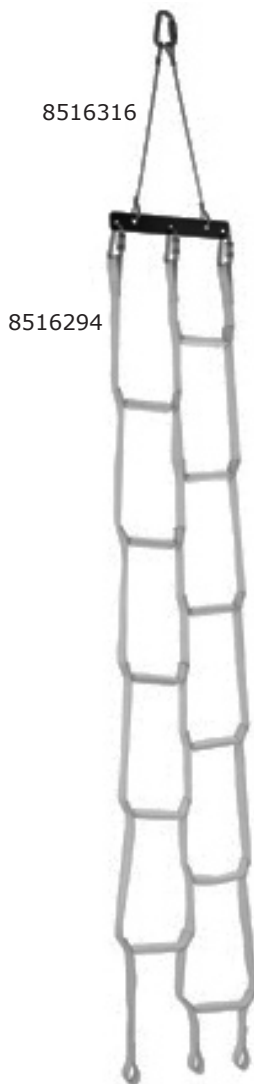



**Figure 1 - Parts Identification**

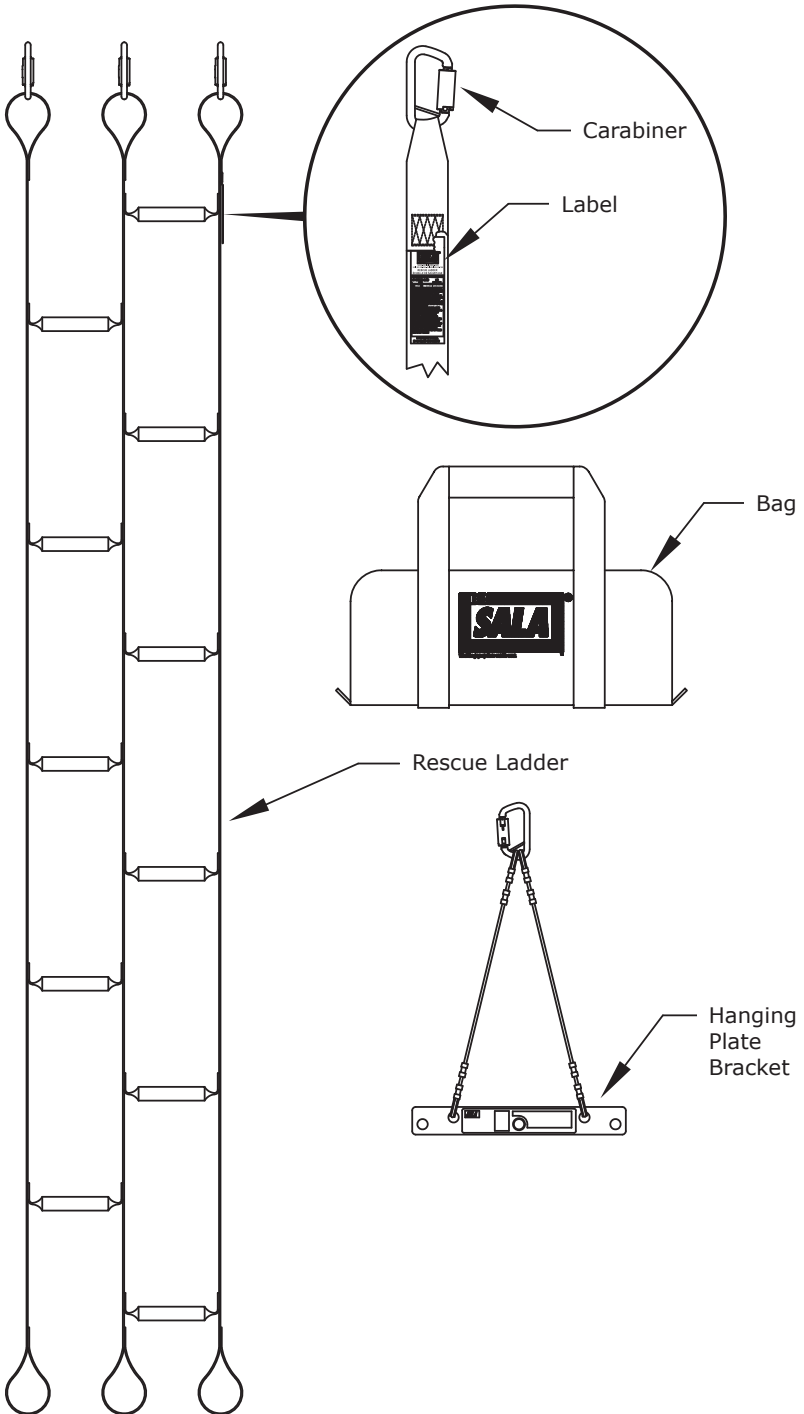

## 1.0 APPLICATIONS

**1.1 PURPOSE:** The DBI-SALA Rescue Ladder system is designed for rescuing fall victims. It can be used to climb to the victim and administer assistance. It can also be presented to the victim to allow them to climb up or down the ladder to safety.

**IMPORTANT:** *The maximum working load for the Rescue Ladder is one person, combined weight (person, clothes, tools, etc.) not exceeding 310 lbs (141 kg).*

**WARNING:** *When using the Rescue Ladder, the rescuer should be secured by a fall protection system.*

**1.2 LIMITATIONS:** The following application limitations must be recognized and considered before using this product:

- A. CORROSION:** Do not leave this equipment for long periods in environments where corrosion of metal parts could take place as a result of vapors rising into the atmosphere from organic materials. Caution should be exercised when working around sewage or fertilizer because of their high concentration of ammonia, which is very corrosive. Use near sea water or other corrosive environments may require more frequent inspections or servicing to assure corrosion damage is not affecting the performance of the product.
- B. CHEMICAL HAZARDS:** Solutions containing acids, alkali or other caustic chemicals, particularly at elevated temperatures, may damage the Rescue Ladder. When working with such chemicals, frequent inspection of the entire Rescue Ladder must be completed. Consult Capital Safety if doubt exists concerning using this equipment around chemical hazards.
- C. HEAT:** In general, the Rescue Ladder is not intended for use in environments where incendiary sparking could cause an explosion or fire. Use of this equipment is prohibited where there exists the possibility of the ladder coming into contact with power lines, live cables, etc. Consult the manufacturer for special applications of this equipment. Do not use where air temperatures exceed 200° F (93°C) or where the ladder may come into contact with material that is above 150° F (65°C).

- D. CAPACITY:** The Rescue Ladder is designed for use by one person with a combined weight (person, clothing, tools, etc.) of 310 lbs (141 kg) maximum. At no time shall more than one person be on the ladder.
- E. TRAINING:** This equipment is intended to be installed and used by persons who have been properly trained in its correct application and use.

**NOTE:** Other hazards may exist. Contact Capital Safety with any concerns regarding your intended use of the Rescue Ladder.

**IMPORTANT:** Refer to applicable local, state and federal (OSHA) requirements governing this equipment for additional information regarding personal fall arrest systems and associated system components.

**WARNING:** Manufacturer's instructions must be followed for proper system use and maintenance of this product. Alterations or misuse of this system or failure to follow instructions may result in serious injury or death.

## **2.0 SYSTEM REQUIREMENTS**

- 2.1 COMPATIBILITY OF COMPONENTS:** The Rescue Ladder system is designed for use only with DBI-SALA approved components. Substitutions or replacements made with non-approved components and subsystems may jeopardize compatibility of equipment and may affect the safety and reliability of the complete system. Contact Capital Safety if you have any questions about compatibility.
- 2.2 COMPATIBILITY OF CONNECTORS:** Connectors are considered to be compatible with connecting elements when they have been designed to work together in such a way that their sizes and shapes do not cause their gate mechanisms to inadvertently open regardless of how they become oriented. Connectors (hooks, carabiners, and D-rings) must be capable of supporting at least 5,000 lbs. (22 kN). Connectors must be compatible with the anchorage or other system components. See Figures 4 and 5 and section 3.4 for additional information on anchorage connections. Do not use equipment that is not compatible. Non-compatible connectors may unintentionally disengage (see Figure 2). Connectors must be compatible in size, shape, and strength. Self locking snap hooks and carabiners are required by ANSI Z359.1 and OSHA.

## Figure 2 - Unintentional Disengagement (Rollout)

If the connecting element to which a snap hook (shown) or carabiner attaches is undersized or irregular in shape, a situation could occur where the connecting element applies a force to the gate of the snap hook or carabiner. This force may cause the gate (of either a self-locking or a non-locking snap hook) to open, allowing the snap hook or carabiner to disengage from the connecting point.

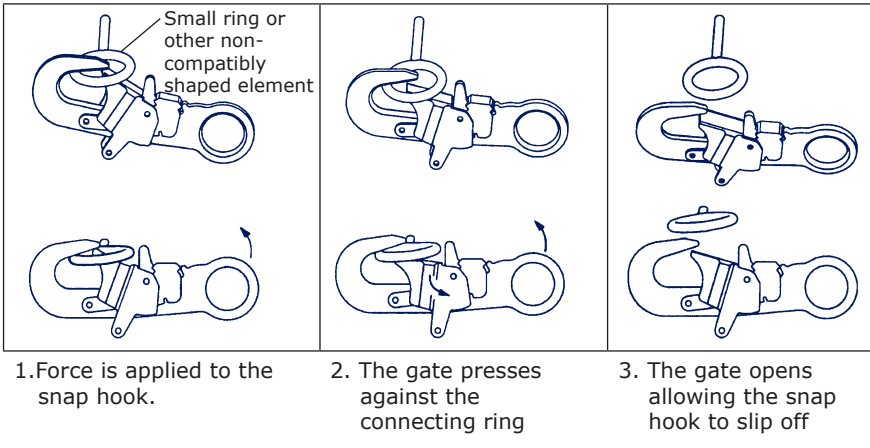

**2.3 MAKING CONNECTIONS:** Only use self-locking snap hooks and carabiners with this equipment. Only use connectors that are suitable to each application. Ensure all connections are compatible in size, shape and strength. Do not use equipment that is not compatible. Ensure all connectors are fully closed and locked.

DBI-SALA connectors (snap hooks and carabiners) are designed to be used only as specified in each product's user's instructions. See Figure 3 for inappropriate connections. DBI-SALA snap hooks and carabiners should not be connected:

- A.** To a D-ring to which another connector is attached.
- B.** In a manner that would result in a load on the gate.

**NOTE:** Large throat opening snap hooks should not be connected to standard size D-rings or similar objects which will result in a load on the gate if the hook or D-ring twists or rotates. Large throat snap hooks are designed for use on fixed structural elements such as rebar or cross members that are not shaped in a way that can capture the gate of the hook.

**Figure 3 - Inappropriate Connections**

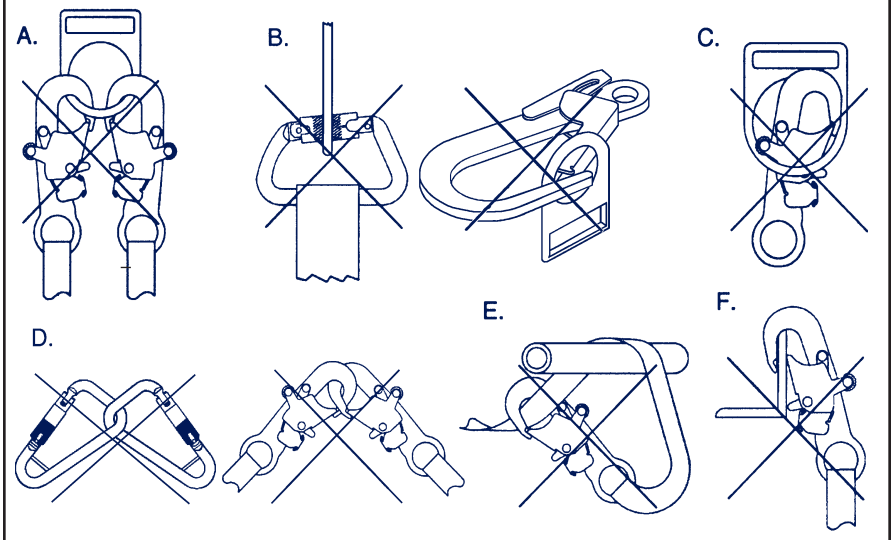

- C.** In a false engagement, where features that protrude from the snap hook or carabiner catch on the anchor and without visual confirmation seems to be fully engaged to the anchor point.
- D.** To each other.
- E.** Directly to webbing or rope lanyard or tie-back (unless the manufacturer's instructions for both the lanyard and connector specifically allow such a connection).
- F.** To any object which is shaped or dimensioned such that the snap hook or carabiner will not close and lock, or that roll-out could occur.

**2.4 ANCHORAGE STRENGTH:** Anchorages selected for the Rescue Ladder system shall have a strength capable of sustaining static loads applied in the directions permitted by the system of at least 3,000 lbs (13.3 kN).

## 3.0 OPERATION AND USE

**WARNING:** Do not alter or intentionally misuse this equipment. Consult Capital Safety when using this equipment in combination with components or subsystems other than those described in this manual. Some subsystem and component combinations may interfere with the operation of this equipment. Use caution when using this equipment around moving machinery, electrical hazards, chemical hazards, sharp edges, and abrasive surfaces.

**WARNING:** Consult your doctor if there is any reason to doubt your fitness to safely absorb the shock from a fall arrest or suspension. Age and fitness seriously affect a worker's ability to withstand falls. Pregnant women or minors must not use DBI-SALA rescue devices unless in an emergency situation.

- 3.1 BEFORE EACH USE:** Before each use of this equipment, carefully inspect it to assure that it is in serviceable condition. Check for worn or damaged parts. Inspect the web material, for cuts, fraying, burns, etc. Refer to section 5.0 for further inspection details. Do not use if inspection reveals an unsafe condition.
- 3.2 PLANNING:** Plan your rescue system and how it will be used before starting your work. Take into consideration factors that affect your safety before, during, and after a fall. The following list gives some important points to consider when planning your system:
- A. ANCHORAGE:** Select an anchorage point that is rigid and capable of supporting 3,000 lbs. (13.3 kN). See Figures 4 and section 2.3. The anchorage location must be carefully selected to reduce possible swing fall hazards and to avoid striking an object during a fall.
  - B. SHARP EDGES:** Avoid working where the web will be in contact with or abrade against sharp edges. If working with this equipment around sharp edges is unavoidable, provide protection by using a heavy pad over the exposed sharp edge.
- 3.3 MAKING CONNECTIONS:** Self locking snap hooks or self locking and self closing gate carabiners must be used to reduce the possibility of roll-out when making connections. See sections 2.2 and 2.3. Do not use hooks or connectors that will not completely close over the attachment object. Do not use non-locking snap hooks. Always follow the manufacturer's instructions supplied with each system component.



**3.4 SETUP AND INSTALLATION:** The anchorage point for the Rescue Ladder system must be capable of supporting 3,000 lbs (13.3 kN). The Rescue Ladder may be secured to the anchorage by any of the following methods:

- Connect the three carabiners on the ladder directly to the anchorage. Each carabiner should have its own connection point (hole).
- Connect the ladder to the anchorage with a Hanging Plate Bracket (PN 8516316). Figure 4 illustrates connection to the anchorage point with a Hanging Plate Bracket. See Section 2.2 for connector compatibility recommendations.

**IMPORTANT:** *An independent fall protection system is required by law (OSHA). Do not connect fall protection equipment directly to the Rescue Ladder. Fall protection systems must be connected to an independent anchor with a minimum tensile strength of 5,000 lbs. (measured in direction of possible fall). Refer to ANSI Z359.1, ANSI A10.14, applicable local, state, and federal (OSHA) requirements and Capital Safety for additional information on independent fall protection systems.*

**WARNING:** *Read and follow manufacturer's instructions for associated equipment (full body harness, etc.) used with this system.*

**3.5 CONNECTING MULTIPLE LADDERS:** Multiple Rescue Ladders can be connected together to accommodate distances that exceed the length of a single ladder (see Figure 5).

## **4.0 TRAINING**

**4.1** It is the responsibility of the user to assure they are familiar with these instructions, and are trained in the correct care and use of this equipment. Users must also be aware of the operating characteristics, application limits, and the consequences of improper use of this equipment.

**IMPORTANT:** *Training must be conducted without exposing the trainee to a fall hazard. Training should be repeated on a periodic basis*

**Figure 4 - Hanging Plate Bracket**

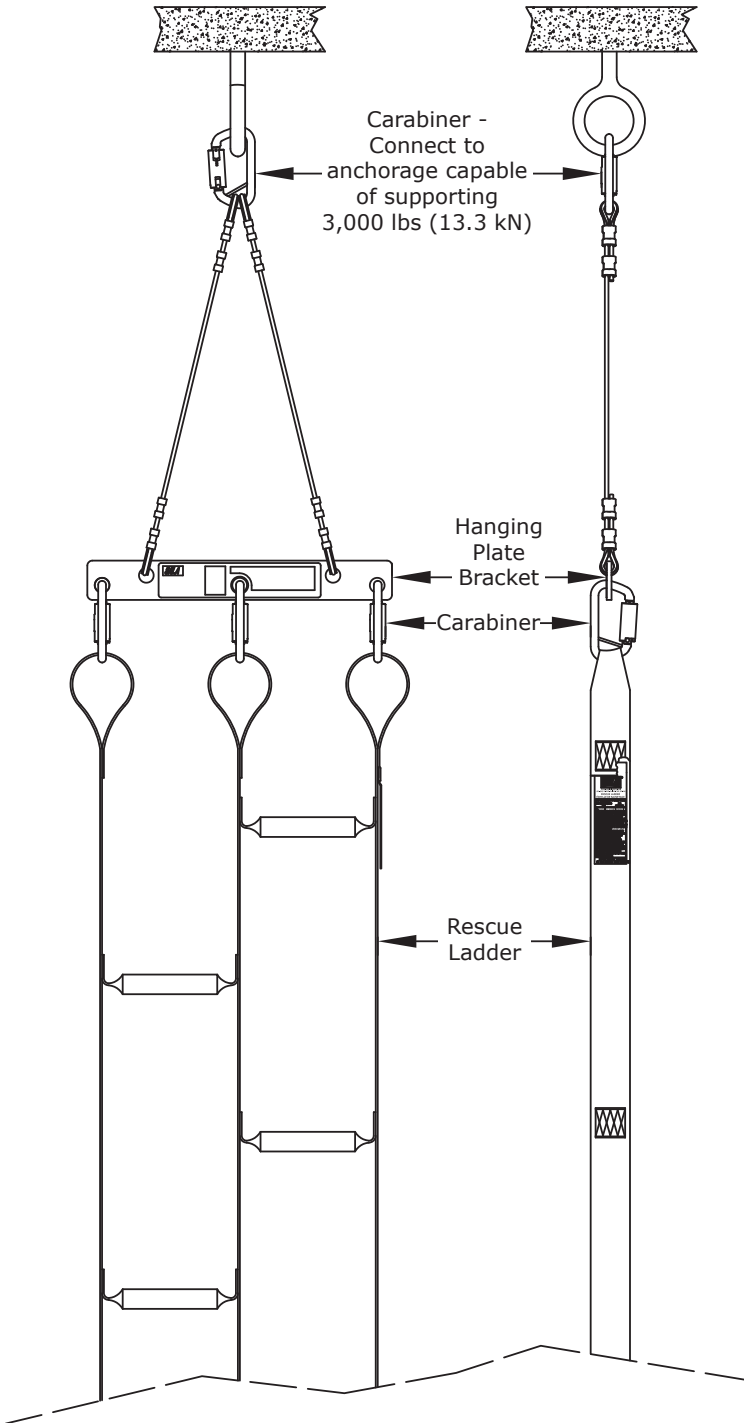

**Figure 5 - Connecting Multiple Rescue Ladders**

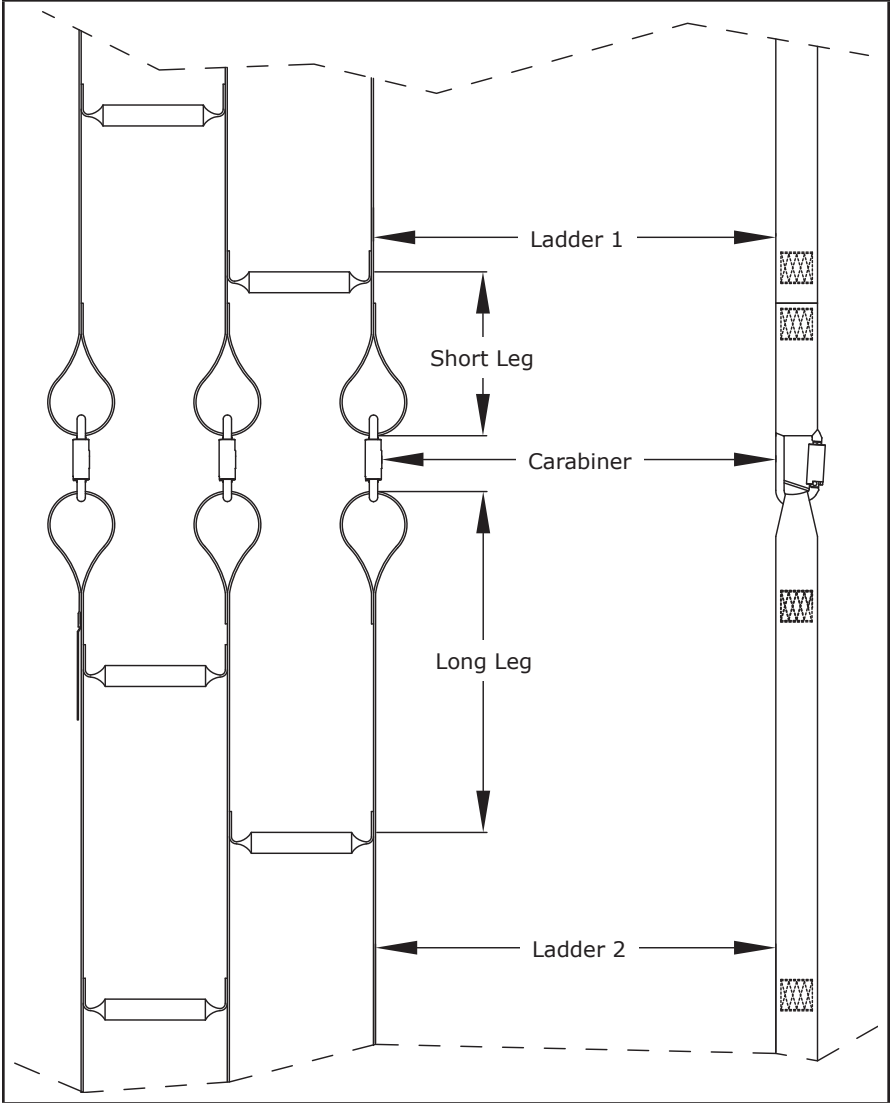

## 5.0 INSPECTION

### 5.1 FREQUENCY:

- **Before Each Use:** Visually inspect per steps listed in sections 5.2 and 5.3.
- **Monthly:** A formal inspection of the Rescue Ladder system should be done by a competent person other than the user. See sections 5.2 and 5.3 for guidelines. Record the results in the Inspection and Maintenance Log in section 9.0.
- **Annually:** It is recommended that the Rescue Ladder system be serviced by a factory authorized service center or the manufacturer. Extreme working conditions may indicate the necessity to increase the frequency. Annual servicing shall include, but not be limited to, an intensive inspection and cleaning of all internal and external components. Failure to provide proper service may considerably shorten product life and could endanger performance. See section 8.0.

**IMPORTANT:** *Extreme working conditions (harsh environment, prolonged use, etc.) may require increasing the frequency of inspections.*

**5.2 INSPECTION STEPS:** Inspect the ladder(s), bracket, and carabiners that comprise the Rescue Ladder system per the following instructions:

**Step 1.** Inspect the ladder(s):

- Inspect webbing: Material must be free of frayed, cut, or broken fibers. Check for tears, abrasions, mold, burns, or discoloration.
- Inspect stitching: Check for pulled or cut stitches. Broken stitches may indicate the ladder has been impact loaded and must be removed from service.
- Inspect labels: All labels (illustrated in Section 8.0) must be present and fully legible.

**Step 2.** Inspect the bracket:

- Inspect for bent or damaged parts:
- Make certain the frame is not damaged or distorted.
- Inspect ferrules for cracks or damage.

- Inspect wire rope for cuts, kinks, broken wires, bird-caging, corrosion, welding splatter, chemical contact, or severe abrasion.
- Inspect the identification and warning label (illustrated in Section 8.0). The label must be present and fully legible.

**Step 3.** Inspect the carabiners:

- Inspect all carabiners for bent or damaged parts.
- Ensure the gate on each carabiner closes properly and remains locked.

**Step 4.** Inspect any additional system components or subsystems according to the manufacturer's instructions.

**NOTE:** Record the inspection date and results in the *Inspection and Maintenance Log* (see Section 9.0).

**5.3 DEFECTS:** If inspection or operation reveals a defective condition, remove the defective component from service immediately and contact an authorized service center for repair.

**NOTE:** Only Capital Safety or parties authorized in writing may make repairs to this equipment.

**5.4 PRODUCT LIFE:** The functional life of the DBI-SALA Rescue Ladder system is determined by work conditions and maintenance. As long as the product passes inspection criteria, it may remain in service.

## **6.0 MAINTENANCE - SERVICE - STORAGE**

**6.1 CLEANING - BRACKETS & CARABINERS:** Periodically clean brackets and carabiners using water and a mild soap detergent solution.

**6.2 CLEANING - RESCUE LADDER:** Clean the ladder with a mild soap solution. Do not use bleach or bleach solution. Wipe off hardware with a clean, dry cloth, and hang to air dry. Do not force dry with heat. An excessive buildup of dirt, paint, etc. may prevent the ladder from working properly, and severe cases degrade the webbing to a point where it weakens and should be removed from service. Additional information on cleaning is available from Capital Safety. If you have questions concerning the condition of your safety ladder, or have any doubt about putting it into service, contact Capital Safety.

**6.3 ADDITIONAL MAINTENANCE AND SERVICE:** Additional maintenance and service procedures must be completed by a factory authorized service center. Do not attempt to disassemble the unit.

**6.4 STORAGE:** Store the Rescue Ladder system in a cool dry, clean environment out of direct sunlight. Avoid areas where chemical vapors may exist. Thoroughly inspected the Rescue Ladder system after extended storage.

## 7.0 SPECIFICATIONS

- Ladder:** Polyester Web  
Polyester Thread Stitching
- Bracket:** Black Anodized Aluminum  
Galvanized Wire Rope - 3/16 in (5 mm) dia. - 7 x 19 construction
- Carabiner:** Plated Alloy Steel

## 8.0 LABELING

The following labels should be securely attached to the Rescue Ladder and Bracket:

### Rescue Ladder Label

	
<a href="http://www.capitalsafety.com">www.capitalsafety.com</a> USA: (800) 328-6146 - CANADA: (800) 387-7484	
<b>RESCUE LADDER</b> <b>ÉCHELLE DE SAUVETAGE</b>	
MODEL NUMBER/NUMERO DU MODELE: B516294	
N° (FR/NO)/# (A/NUM):	LOT:
XX/XX	XXXXXXXX
<b>WARNING / AVERTISSEMENT</b>	
<p>MANUFACTURER'S INSTRUCTIONS MUST BE READ AND UNDERSTOOD PRIOR TO USE. INSTRUCTIONS SUPPLIED WITH THIS PRODUCT AT TIME OF SHIPMENT MUST BE FOLLOWED. FAILURE TO DO SO COULD RESULT IN SERIOUS INJURY OR DEATH. INSPECT BEFORE EACH USE. DO NOT USE IF WEAR OR DAMAGE IS PRESENT. THIS ITEM IS NOT FLAME OR HEAT RESISTANT. DO NOT USE AS AN ANCHORAGE CONNECTOR. SINGLE USER ONLY. LES INSTRUCTIONS DU FABRICANT DOIVENT ÊTRE LUES ET COMPRIS AVANT L'UTILISATION. ON DOIT OBSERVER LES INSTRUCTIONS DU FABRICANT FOURNIES AU MOMENT DE L'EXPÉDITION. NÉGLIGER D'OBSERVER LES INSTRUCTIONS PEUT ENTRAÎNER UNE BLESSURE GRAVE, VOIRE MORTELLE. INSPECTER AVANT CHAQUE UTILISATION. NE PAS UTILISER S'IL Y A DES TRACES D'USURE OU D'ENDOMMAGEMENT. CE PRODUIT N'EST PAS RÉSISTANT AUX FLAMMES OU À LA CHALEUR. NE PAS UTILISER COMME MOYEN D'ANCRAGE. UN UTILISATEUR SEULEMENT.</p>	
DO NOT REMOVE THIS LABEL NE PAS ENLEVER CETTE ÉTIQUETTE	

Front

CONNECTING TWO LADDERS  
CONNECTER DEUX ÉCHELLES:

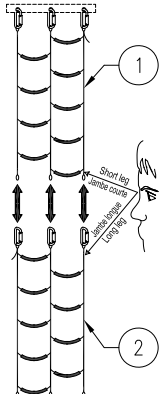

SPECIFICATIONS / CARACTÉRISTIQUES:  
 CAPACITY/CAPACITÉ: 310 lbs (141 kg)  
 LENGTH/LONGUEUR: 8 ft (2.4 m)  
 MATERIAL/MATÉRIEL:  
 Polyester web/Sangle en polyester  
 Plated steel carabiner/Mousquetons en acier plaqué

Back

### Bracket Label

<b>WARNING / AVERTISSEMENT</b>	
<p>MANUFACTURER'S INSTRUCTIONS MUST BE READ AND UNDERSTOOD PRIOR TO USE. INSTRUCTIONS SUPPLIED WITH THIS PRODUCT AT TIME OF SHIPMENT MUST BE FOLLOWED. FAILURE TO DO SO COULD RESULT IN SERIOUS INJURY OR DEATH. INSPECT BEFORE EACH USE. DO NOT USE IF WEAR OR DAMAGE IS PRESENT. THIS ITEM IS NOT FLAME OR HEAT RESISTANT. DO NOT USE AS AN ANCHORAGE CONNECTOR. SINGLE USER ONLY. LES INSTRUCTIONS DU FABRICANT DOIVENT ÊTRE LUES ET COMPRIS AVANT L'UTILISATION. ON DOIT OBSERVER LES INSTRUCTIONS DU FABRICANT FOURNIES AU MOMENT DE L'EXPÉDITION. NÉGLIGER D'OBSERVER LES INSTRUCTIONS PEUT ENTRAÎNER UNE BLESSURE GRAVE, VOIRE MORTELLE. INSPECTER AVANT CHAQUE UTILISATION. NE PAS UTILISER S'IL Y A DES TRACES D'USURE OU D'ENDOMMAGEMENT. CE PRODUIT N'EST PAS RÉSISTANT AUX FLAMMES OU À LA CHALEUR. NE PAS UTILISER COMME MOYEN D'ANCRAGE. UN UTILISATEUR SEULEMENT. LES INSTRUCTIONS DU FABRICANT DOIVENT ÊTRE LUES ET COMPRIS AVANT L'UTILISATION. ON DOIT OBSERVER LES INSTRUCTIONS DU FABRICANT FOURNIES AU MOMENT DE L'EXPÉDITION. NÉGLIGER D'OBSERVER LES INSTRUCTIONS PEUT ENTRAÎNER UNE BLESSURE GRAVE, VOIRE MORTELLE. INSPECTER AVANT CHAQUE UTILISATION. NE PAS UTILISER S'IL Y A DES TRACES D'USURE OU D'ENDOMMAGEMENT. CE PRODUIT N'EST PAS RÉSISTANT AUX FLAMMES OU À LA CHALEUR. NE PAS UTILISER COMME MOYEN D'ANCRAGE. UN UTILISATEUR SEULEMENT.</p>	
	
DO NOT REMOVE THIS LABEL NE PAS ENLEVER CETTE ÉTIQUETTE	
<p>MANUFACTURER'S INSTRUCTIONS MUST BE READ AND UNDERSTOOD PRIOR TO USE. INSTRUCTIONS SUPPLIED WITH THIS PRODUCT AT TIME OF SHIPMENT MUST BE FOLLOWED. FAILURE TO DO SO COULD RESULT IN SERIOUS INJURY OR DEATH. INSPECT BEFORE EACH USE. DO NOT USE IF WEAR OR DAMAGE IS PRESENT. THIS ITEM IS NOT FLAME OR HEAT RESISTANT. DO NOT USE AS AN ANCHORAGE CONNECTOR. SINGLE USER ONLY. LES INSTRUCTIONS DU FABRICANT DOIVENT ÊTRE LUES ET COMPRIS AVANT L'UTILISATION. ON DOIT OBSERVER LES INSTRUCTIONS DU FABRICANT FOURNIES AU MOMENT DE L'EXPÉDITION. NÉGLIGER D'OBSERVER LES INSTRUCTIONS PEUT ENTRAÎNER UNE BLESSURE GRAVE, VOIRE MORTELLE. INSPECTER AVANT CHAQUE UTILISATION. NE PAS UTILISER S'IL Y A DES TRACES D'USURE OU D'ENDOMMAGEMENT. CE PRODUIT N'EST PAS RÉSISTANT AUX FLAMMES OU À LA CHALEUR. NE PAS UTILISER COMME MOYEN D'ANCRAGE. UN UTILISATEUR SEULEMENT.</p>	
DO NOT REMOVE THIS LABEL NE PAS ENLEVER CETTE ÉTIQUETTE	

# 9.0 INSPECTION AND MAINTENANCE LOG

SERIAL NUMBER: \_\_\_\_\_

MODEL NUMBER: \_\_\_\_\_

DATE PURCHASED: \_\_\_\_\_

INSPECTION DATE	INSPECTION ITEMS NOTED	CORRECTIVE ACTION	MAINTENANCE PERFORMED
Approved By: _____			
Approved By: _____			
Approved By: _____			
Approved By: _____			
Approved By: _____			
Approved By: _____			
Approved By: _____			
Approved By: _____			
Approved By: _____			
Approved By: _____			
Approved By: _____			
Approved By: _____			

## WARRANTY

Equipment offered by DBI-SALA is warranted against factory defects in workmanship and materials for a period of two years from date of installation or use by the owner, provided that this period shall not exceed two years from date of shipment. Upon notice in writing, DBI-SALA will promptly repair or replace all defective items. DBI-SALA reserves the right to elect to have any defective item returned to its plant for inspection before making a repair or replacement. This warranty does not cover equipment damages resulting from abuse, damage in transit, or other damage beyond the control of DBI-SALA. This warranty applies only to the original purchaser and is the only one applicable to our products, and is in lieu of all other warranties, expressed or implied.



### **CSG USA**

3833 Sala Way  
Red Wing, MN 55066-5005  
Toll Free: 800.328.6146  
Phone: 651.388.8282  
Fax: 651.388.5065  
solutions@capitalsafety.com

### **CSG Canada Ltd.**

260 Export Boulevard  
Mississauga, Ontario L5S 1Y9  
Toll Free: 800.387.7484  
Phone: 905.795.9333  
Fax: 905.795.8777  
sales.ca@capitalsafety.com

[www.capitalsafety.com](http://www.capitalsafety.com)



Certificate No. FM 39709