

Harley-Davidson® Roaring Police Rocker













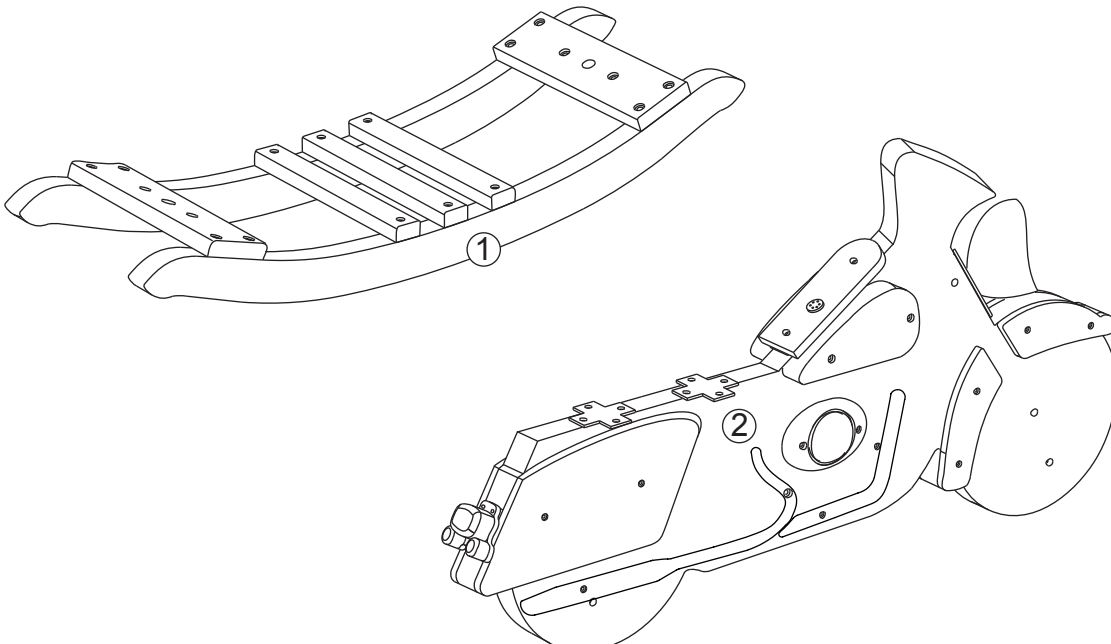
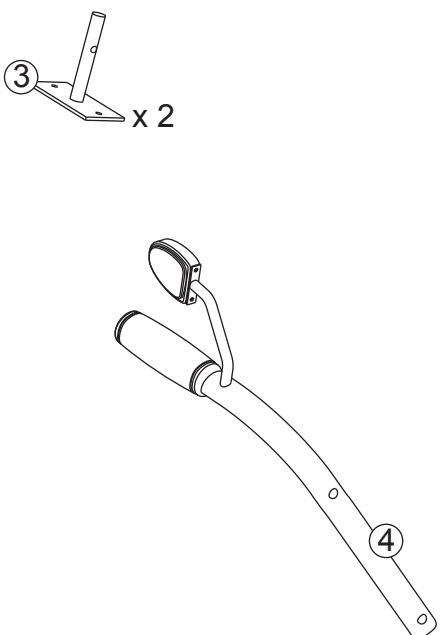

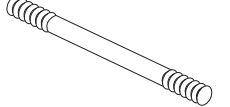
Assembly Instructions

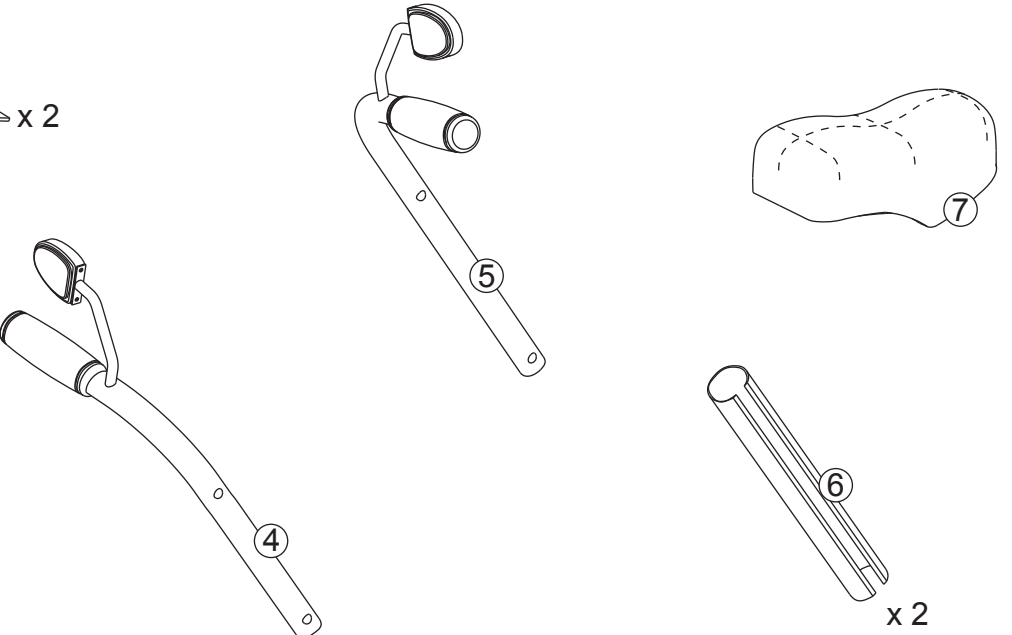
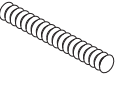
Item #10017

© 2012 KidKraft, LP

Please retain this information for future reference

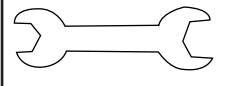
To order replacement parts, please visit www.kidkraft.com

| HARDWARE | | PARTS LIST | |
|---|--|---|---|
| A. Cross Dowel Bolt x 4 pcs  (1 1/8 in / 30 mm) | G. Nut x 4 pcs  |  |  |
| B. Cross Dowel Bolt x 4 pcs  (3/4 in / 18 mm) | H. Cap Nut x 4 pcs  | | |
| C. Two - Side Threaded Rod x 2 pcs  (3 5/8 in / 92 mm) | I. Nylon Lock Nut x 4 pcs  |  | |
| D. Short Threaded Rod x 2 pcs  (2 1/4 in / 56 mm) | J. Large Washer x 4 pcs  | | |
| E. Washer x 8 pcs  | K. Large Lock Washer x 4 pcs  | | |
| F. Lock Washer x 8 pcs  | Allen Wrench x 1 pc  | | |
| | Wrench x 2 pcs  | | |
| | The following tool (not included) is required for assembly:  | | |
| | Phillips® screwdriver | | |

Step 1

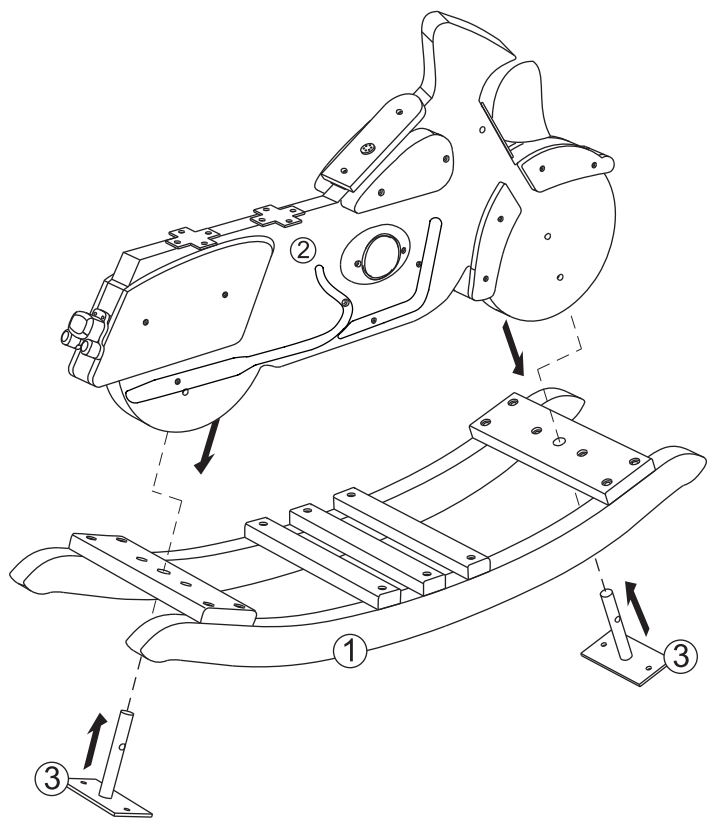

Step 2

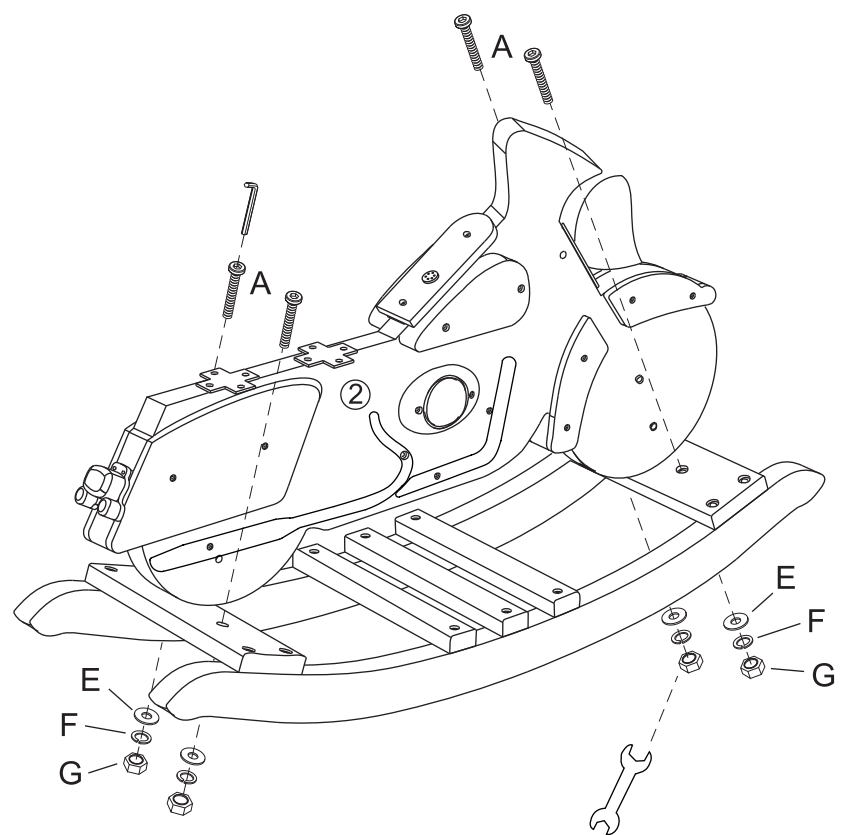

⚠ WARNING:
 ADULT ASSEMBLY REQUIRED. Product includes small parts with potentially hazardous sharp points and sharp edges in the unassembled state. Keep unassembled parts away from children.

USE AND MAINTENANCE:
 -Use on level surfaces only
 -Please check assembly at regular intervals, and frequently tighten hardware if necessary. If maintenance is not carried out, the product could cease to function properly.

⚠ WARNING:
 CHOKING HAZARD. Small parts and sharp points, not suitable for children under 3 years.

Customer Service
 1-800-933-0771
www.kidkraft.com

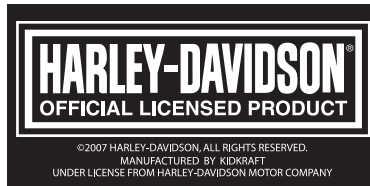

Harley-Davidson® Roaring Police Rocker

Assembly Instructions

Item #10017

Step 3

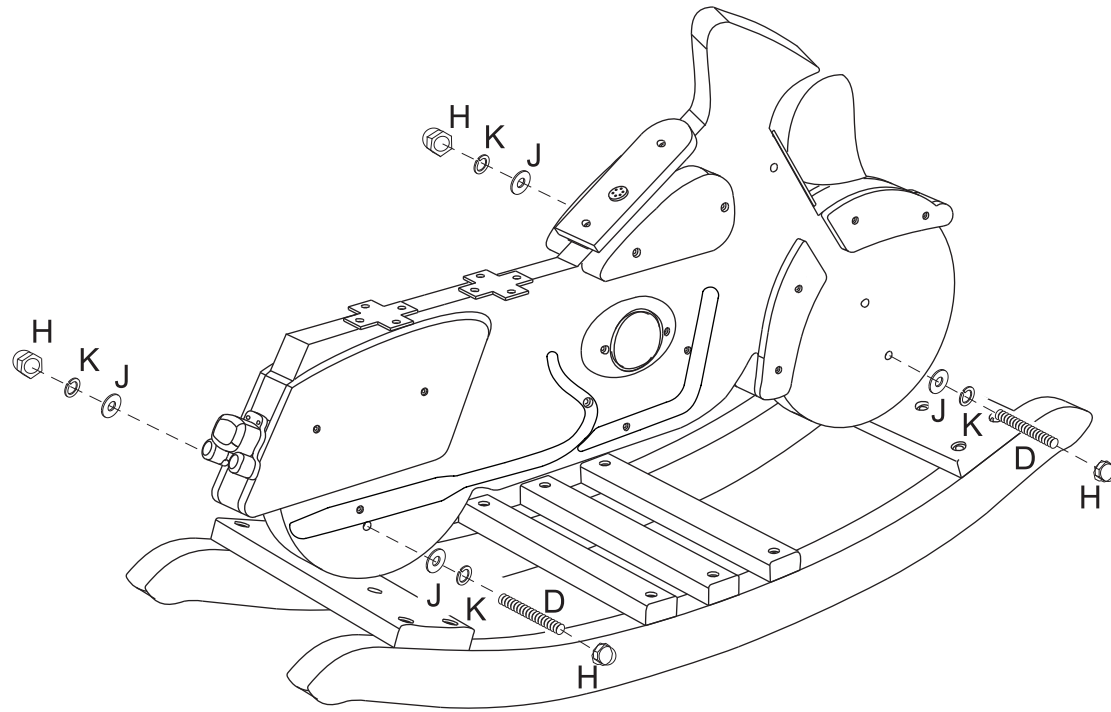

Step 4

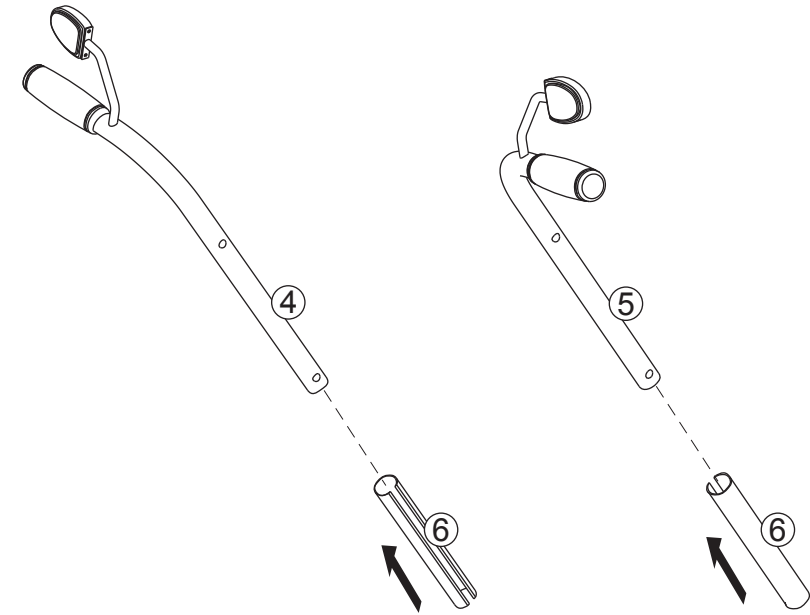

Step 5

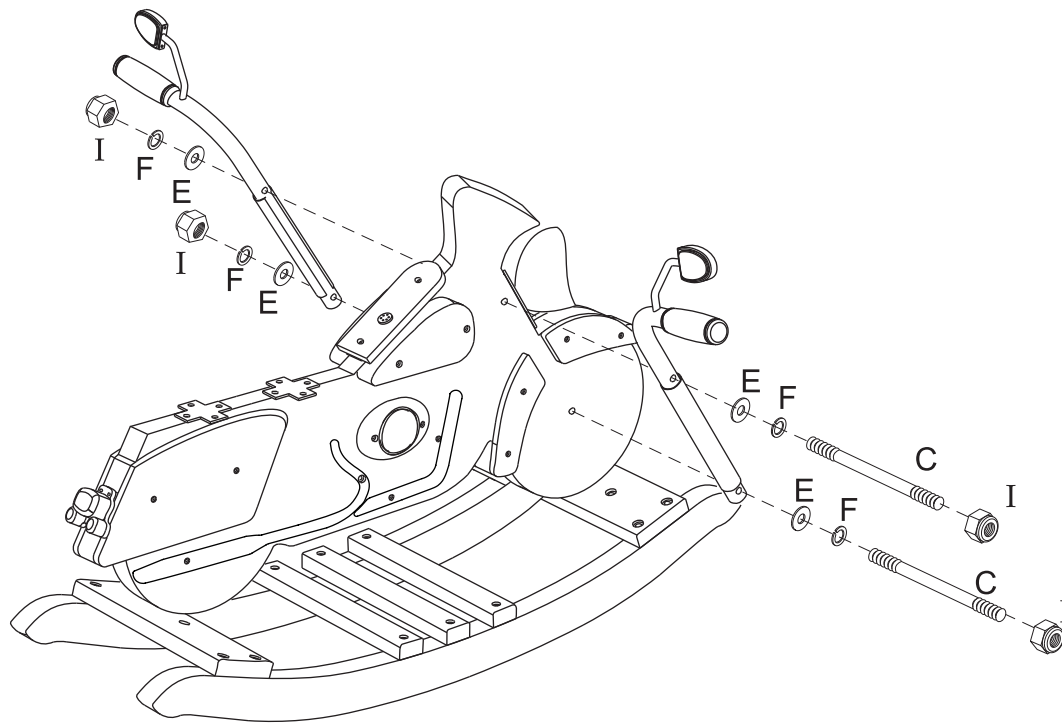

Step 6

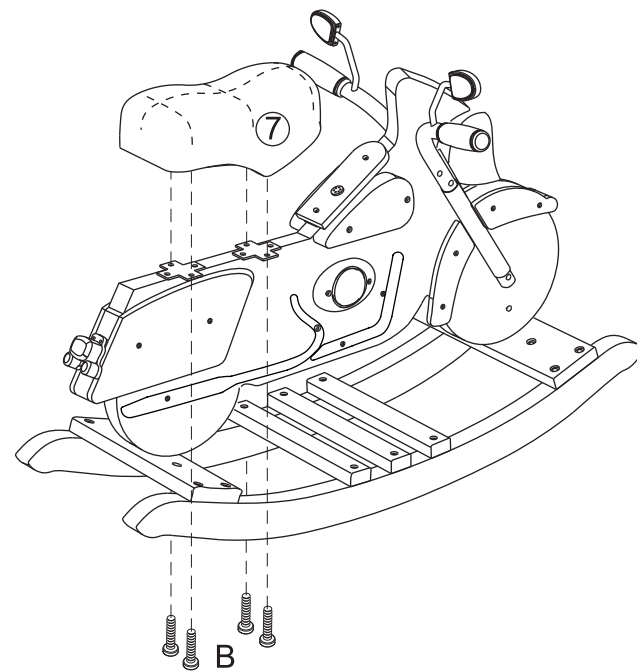

Complete

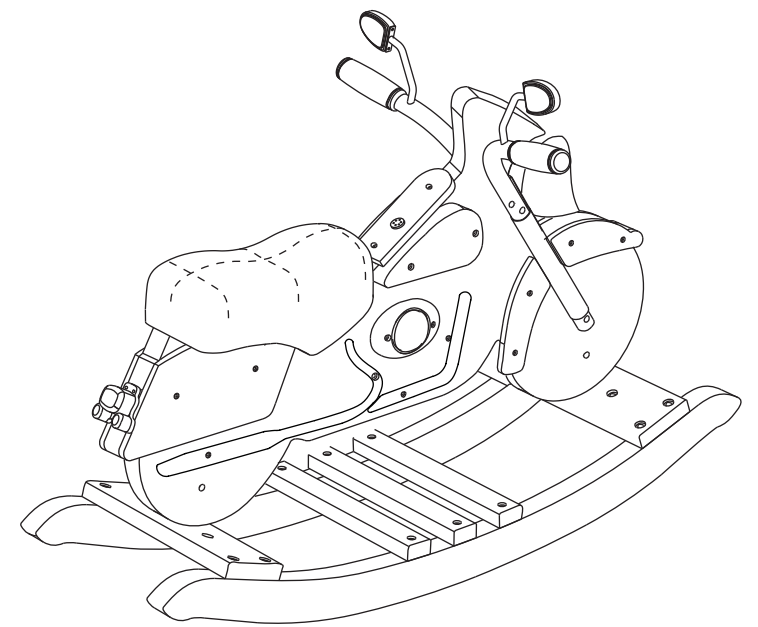

Before calling customer service, please locate the batch code number (example: 105906/65006/04) found on the bottom or back of your product.

Customer Service
1-800-933-0771
www.kidkraft.com

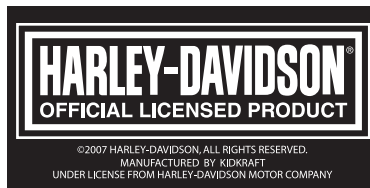

Harley-Davidson® Roaring Police Rocker

Assembly Instructions

Item #10017

Sound Battery Replacement Instructions

Step 1

- Unscrew casing and remove.
- Remove sound box.

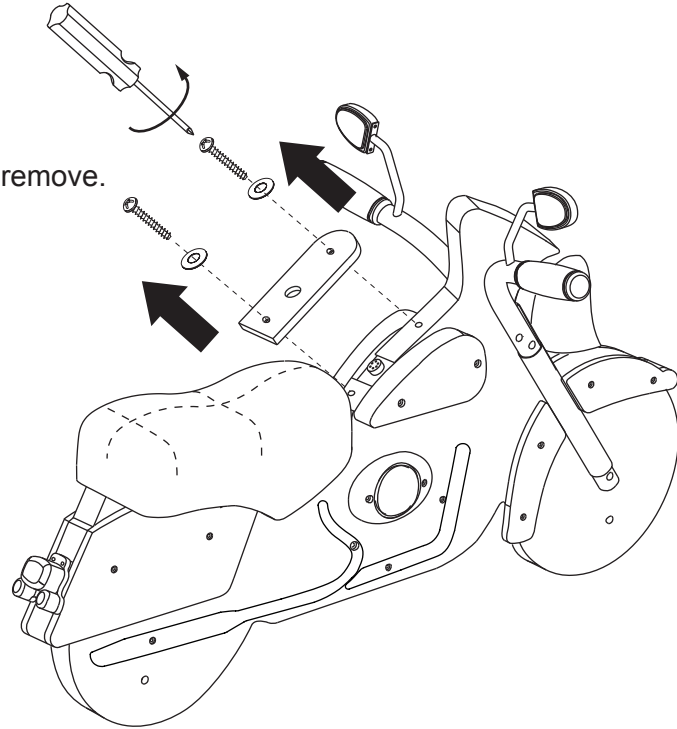

Step 2

- Locate the battery compartment underneath the sound box.

- Use a screwdriver to remove cover.

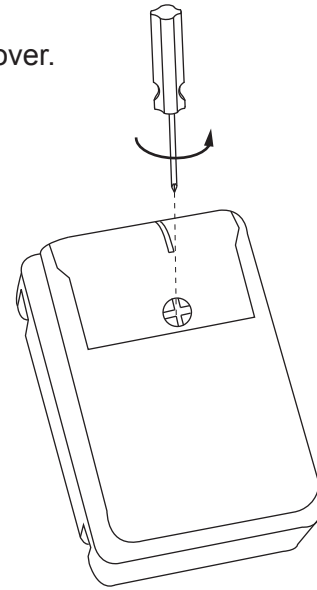

Step 3

- Replace old batteries with three (3) new AG13 batteries.

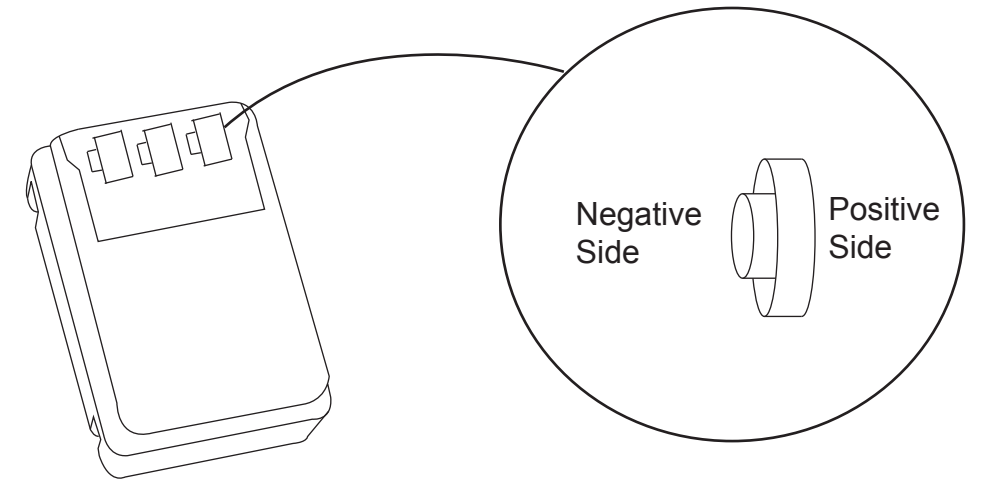

Step 4

- Screw the cover back into place with the screwdriver.

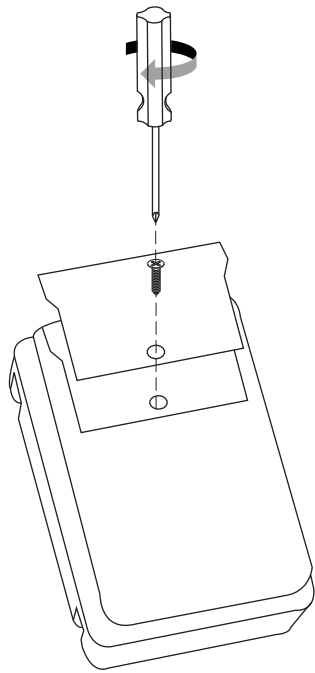

Battery Tips:

- Batteries should always be installed and changed under adult supervision.
- Rechargeable batteries are to be removed from the toy before being charged.
- Non-Rechargeable batteries are not to be recharged.
- Rechargeable batteries are only to be charged under adult supervision.
- Only batteries of the same equivalent type as recommended are to be used.
- Batteries are to be inserted with the correct polarity.
- Exhausted batteries are to be removed from the toy and disposed of properly.
- The supply terminals are not to be short circuited.
- Different types of batteries or new and used batteries are not to be mixed.
- DO NOT mix alkaline, standard (carbon-zinc) or rechargeable batteries.

Step 5

- Place sound box back inside the compartment.
- Place cover back on the bike and screw back on.

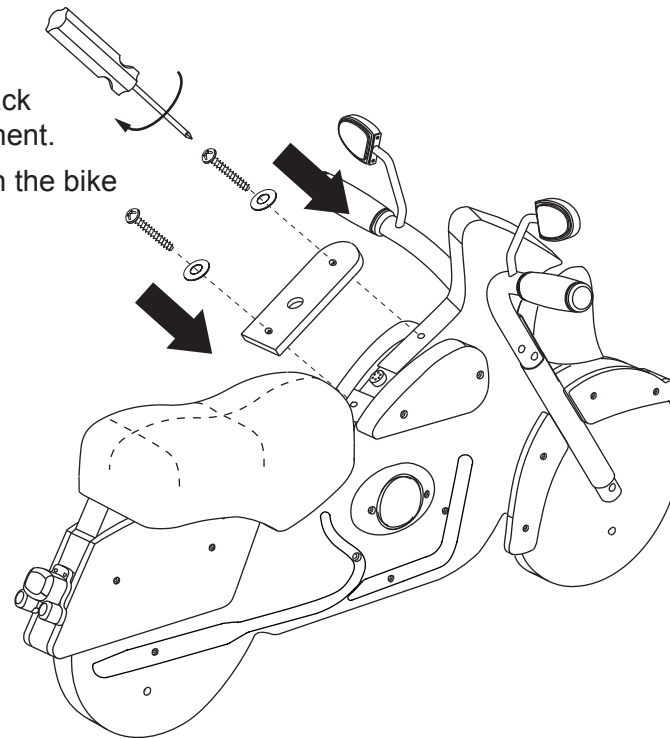

This device complies with Part 15 of the FCC Rules. Operation is subject to the following two conditions: (1) This device may not cause harmful interference, and (2) this device must accept any interference received, including interference that may cause undesired operation.

NOTE: This equipment has been tested and found to comply with the limits for a Class B digital device, pursuant to part 15 of the FCC Rules. These limits are designed to provide reasonable protection against harmful interference in a residential installation. This equipment generates, uses and can radiate radio frequency energy and, if not installed and used in accordance with the instructions, may cause harmful interference to radio communications. However, there is no guarantee that interference will not occur in a particular installation. If this equipment does cause harmful interference to radio or television reception, which can be determined by turning the equipment off and on, the user is encouraged to try to correct the interference by one or more of the following measures:

- Reorient or relocate the receiving antenna.
- Increase the separation between the equipment and receiver.
- Connect the equipment into an outlet on a circuit different from that to which the receiver is connected.
- Consult the dealer or an experienced radio /TV technician for help.

Customer Service
1-800-933-0771
www.kidkraft.com



IMPORTANT INFORMATION - PLEASE READ FIRST

ALL OF OUR WOODEN ITEMS ARE HANDCRAFTED, HAND ASSEMBLED, AND HAND PAINTED. EACH ONE IS UNIQUE. SLIGHT IMPERFECTIONS MAY OCCUR AND ARE NOT MANUFACTURING DEFECTS.

PLEASE NOTE THAT WE DO NOT WARRANTY AGAINST THE USE OF PERMANENT MARKERS, NON-WATER-BASED PAINTS, CRAYONS, OR WASHABLE MARKERS. SOME OF THESE ITEMS CONTAIN PERMANENT COLOR DYES THAT COULD DAMAGE THE SURFACE.

CLEANING INSTRUCTIONS

CLEAN THE SURFACE USING A SLIGHTLY DAMP CLOTH AND MILD DISH WASHING LIQUID IF NECESSARY. DO NOT USE ANY CLEANING PRODUCT CONTAINING ALCOHOL OR AMMONIA. THESE WILL DULL THE SHINY SURFACE OF THE PRODUCT. FURNITURE POLISH WILL ALSO WORK TO CLEAN AND DUST OFF THE SURFACE.

WE RECOMMEND THAT YOU TEST ALL CLEANING MATERIALS ON THE UNDERSIDE OF ANY SURFACE THAT WOULD NOT BE SEEN DURING NORMAL USE OF THE PRODUCT. IF YOU HAVE QUESTIONS REGARDING THE MAINTENANCE OF THIS PRODUCT PLEASE FEEL FREE TO CALL US.

SOLE AND LIMITED WARRANTY

THIS TOY IS WARRANTED SOLELY AGAINST MANUFACTURING DEFECTS FOR A PERIOD OF 90 DAYS FROM THE DATE OF PURCHASE, WHICH RUNS ONLY TO THE ORIGINAL USER OF THE PRODUCT. IN THE EVENT OF A MANUFACTURING DEFECT, PARTS WILL BE REPLACED OR THE ENTIRE PRODUCT WILL BE REPLACED OR THE PURCHASE PRICE WILL BE REFUNDED, AT THE ELECTION OF THE MANUFACTURER. TO ACTIVATE AND PROTECT THIS WARRANTY, PRESERVE EVIDENCE OF ORIGINAL PURCHASE AND CAREFULLY INSPECT THE CONDITION OF THIS TOY. SHOULD YOU OBSERVE ANY DEFECTS, DO NOT USE THE TOY AND IMMEDIATELY NOTIFY THE MANUFACTURER. FAILURE TO DO SO SHALL CONSTITUTE MISUSE. MISUSE, IMPROPER ASSEMBLY, FAILURE TO HONOR A WARNING, FAILURE TO SUPERVISE, INSPECT OR MAINTAIN THE TOY, OR DAMAGE TO THE TOY, WHETHER INTENTIONAL OR INADVERTENT, SHALL INVALIDATE THIS WARRANTY. THIS WARRANTY GIVES YOU SPECIFIC LEGAL RIGHTS, AND YOU MAY ALSO HAVE OTHER RIGHTS WHICH VARY FROM STATE TO STATE.

TO SUBMIT A WARRANTY CLAIM PLEASE CONTACT KIDKRAFT CUSTOMER SERVICE AT 1-800-933-0771 FOR INSTRUCTIONS ON HOW TO PROVIDE PROOF OF PURCHASE AND HOW TO RETURN THE ITEM FREIGHT PRE-PAID.

CUSTOMER SERVICE 1-800-933-0771

www.kidkraft.com