



Experiencing problems with your new KidKraft product?

Before returning your product to the store or Internet retailer, please give us a chance to solve all your problems. **For fastest service, please visit www.kidkraft.com**, where you can order replacement parts under warranty free of charge, 24 hours a day. Our Dallas-based Customer Service team can be reached at 1-800-933-0771 and is available 8:30 a.m. to 5:00 p.m. Central Standard Time every Monday through Friday. We want nothing more than for our customers to be satisfied. If you have a question outside of our normal business hours, just leave a message and we will call you back as soon as possible.

- Are our assembly instructions confusing? Are you stuck on a step?

Please, let us help!

- Are you missing a part? Do you need us to send a replacement part?

Please, let us help!

- Did a part arrive broken? Do you need us to send a replacement?

Please, let us help!

- Does the item you received differ in any way from what was ordered?

Please, let us help!

At KidKraft, customer satisfaction is our top priority. Thank you for your business.

David Barr
Executive Vice President

KidKraft
4630 Olin Road
Dallas Texas 75244
www.kidkraft.com
Toll Free: 1.800.933.0771
Tel: 972.385.0100
Fax: 972.385.0277

Before calling customer service, please have your item's batch code ready.
This is your batch code:

If your batch code is not listed here, you can find it on the back or bottom of your product.
(example batch code:105906/65006/04)



© 2012 KidKraft, LP







Pirate Play Set

Assembly Instructions

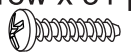
Item #63262

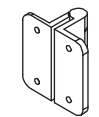
Please retain this information for future reference

To order replacement parts, please visit www.kidkraft.com

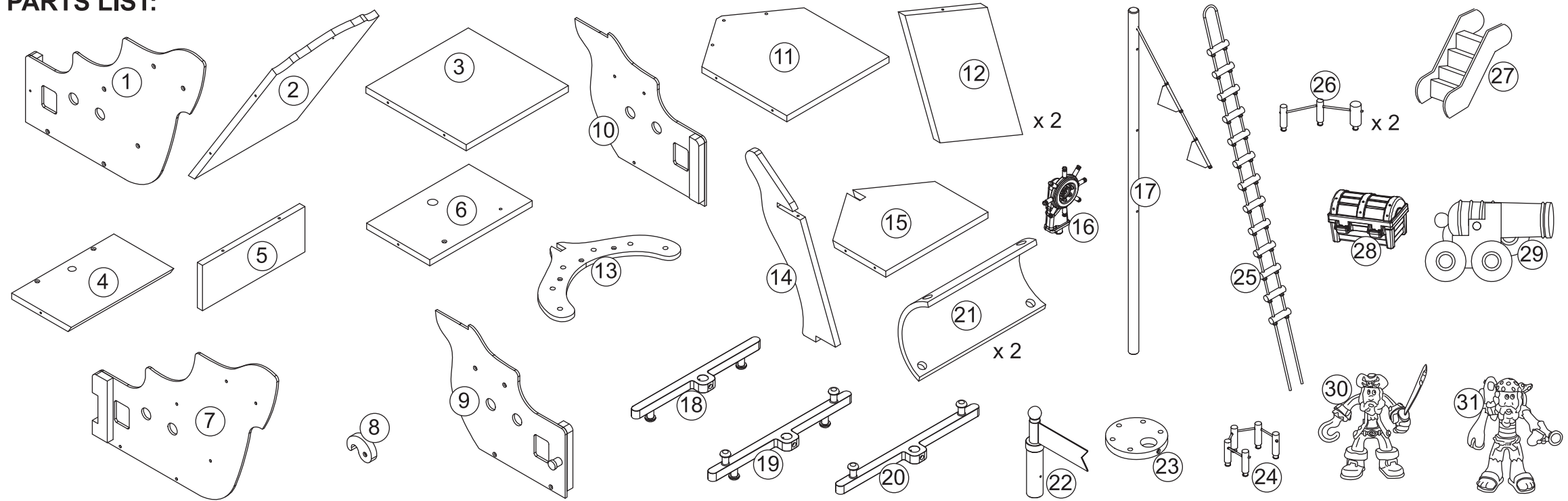
HARDWARE		PARTS LIST:	
<p>A. Screw x 31 pcs  1 1/16 in / 18 mm</p> <p>B. Small Screw x 4 pcs  5/8 in / 15 mm</p> <p>C. Hinge x 1 pc </p> <p>D. Screw x 4 pcs  5/8 in / 15 mm</p> <p>E. Washer x 1 pc </p>	<p>The following tool (not included) is required for assembly:</p>  Phillips® Screwdriver		

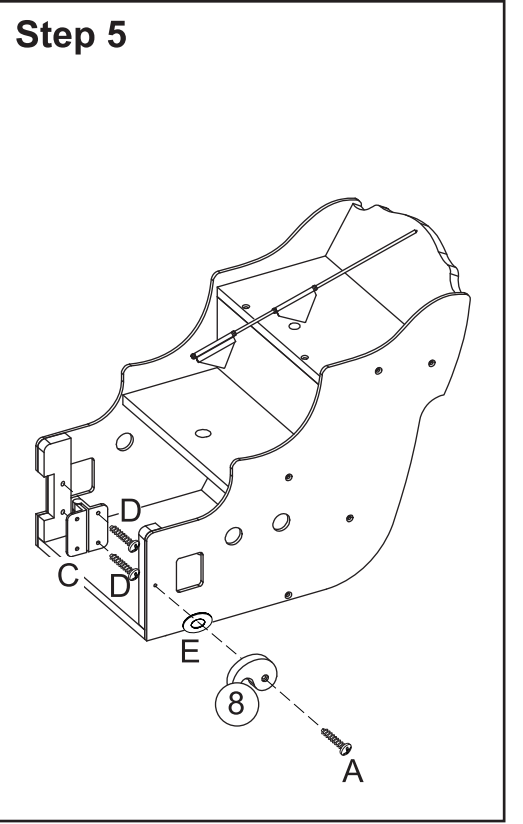
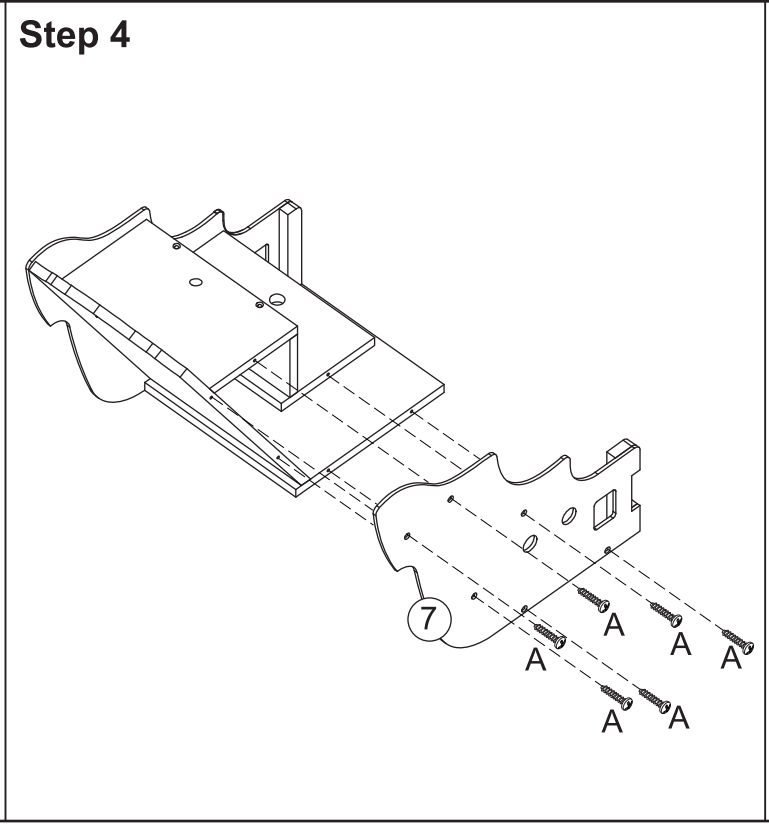
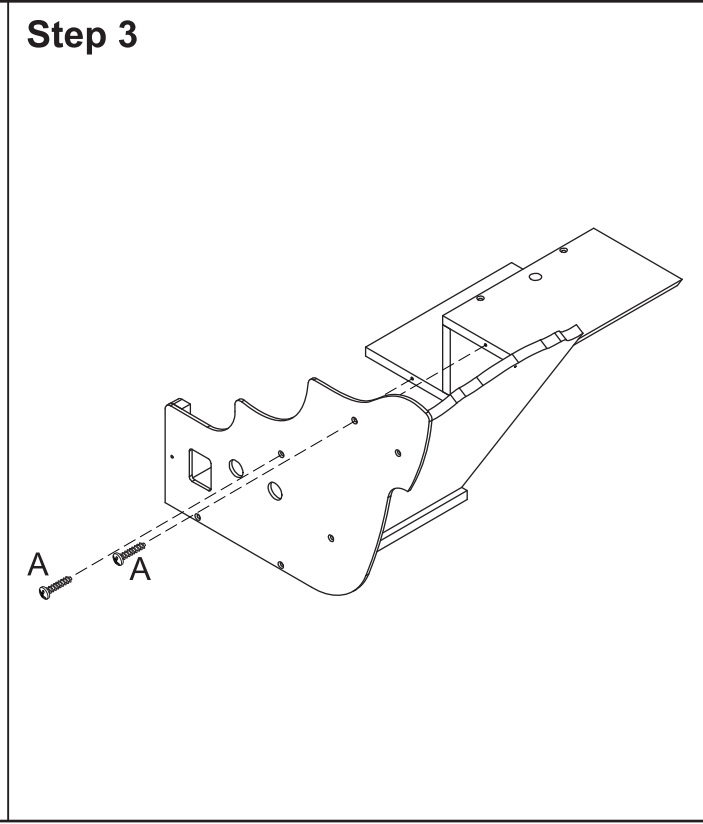
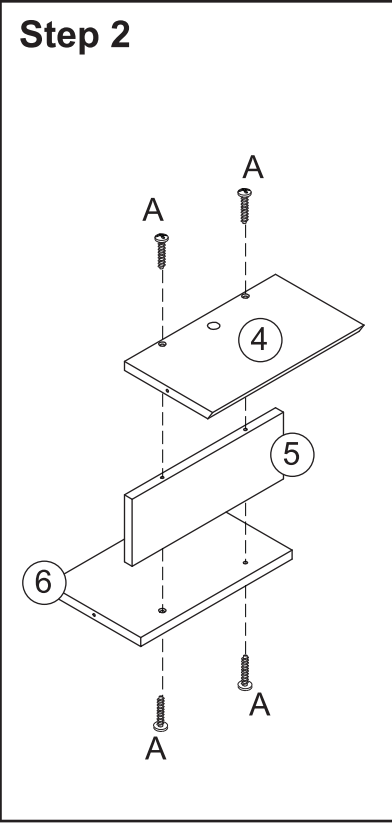
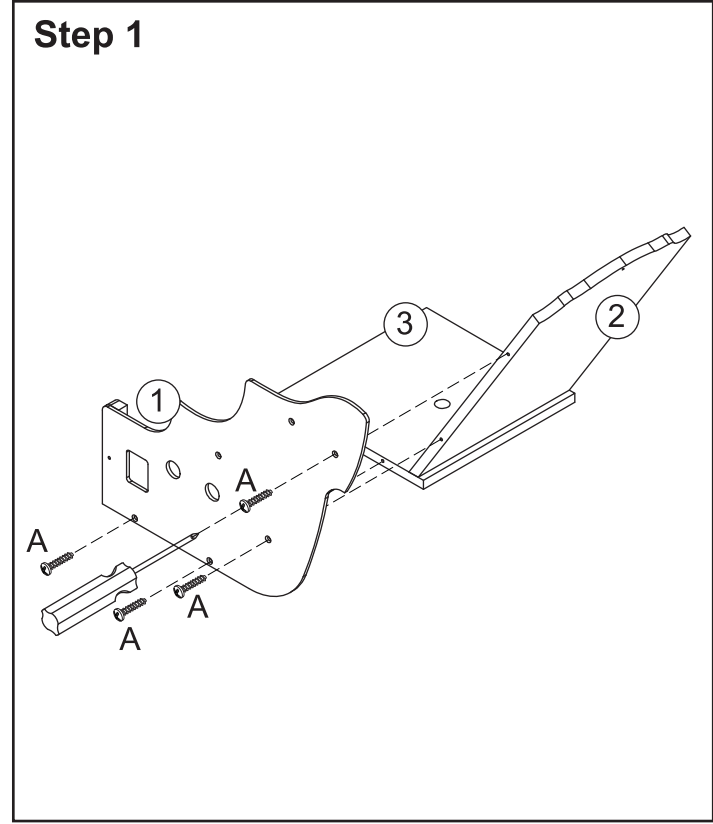

⚠ WARNING:
 ADULT ASSEMBLY REQUIRED. Product includes small parts with potentially hazardous sharp points and sharp edges in the unassembled state. Keep unassembled parts away from children.

USE AND MAINTENANCE:
 -Use on level surfaces only
 -Please check assembly at regular intervals, and frequently tighten hardware if necessary. If maintenance is not carried out, the product could cease to function properly.

⚠ WARNING:
 CHOKING HAZARD. Small parts and sharp points, not suitable for children under 3 years.

Customer Service
 1-800-933-0771
www.kidkraft.com



© 2012 KidKraft, LP

Pirate Play Set

Assembly Instructions

Item #63262

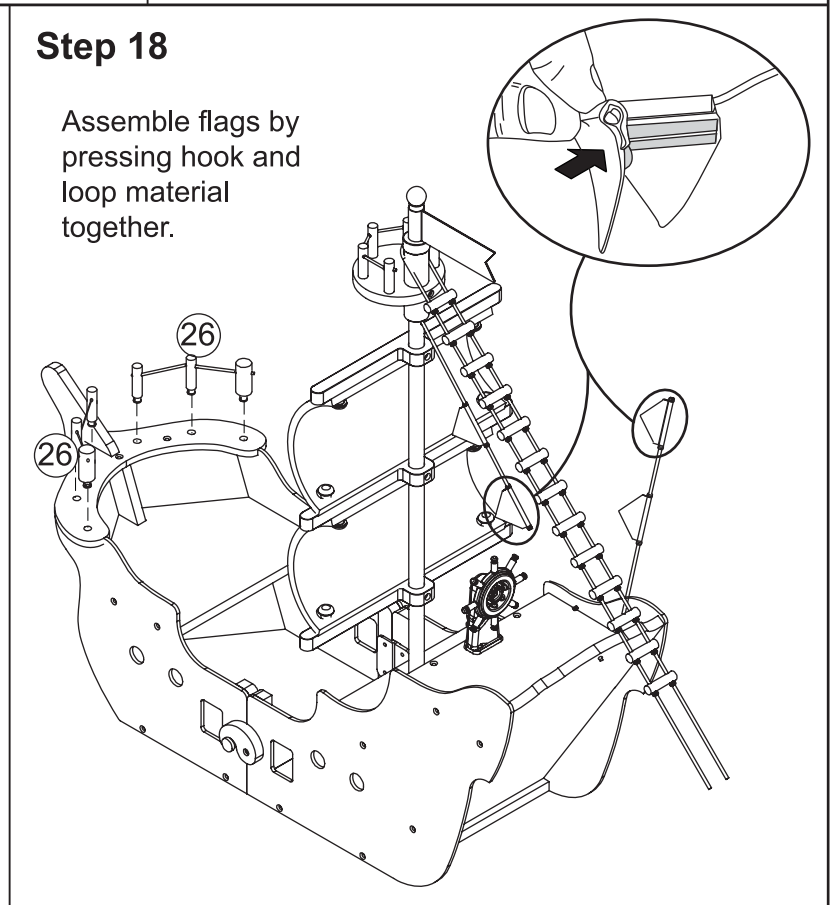
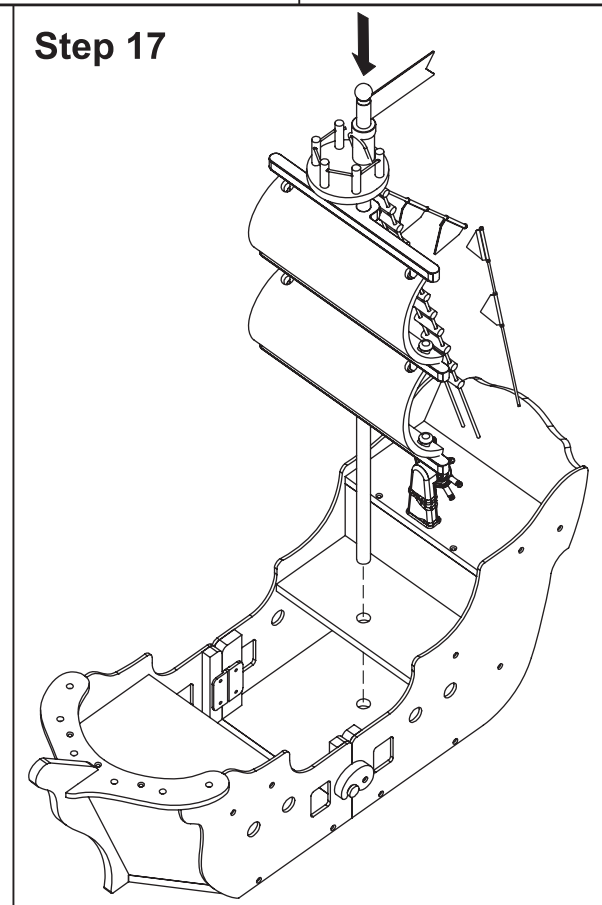
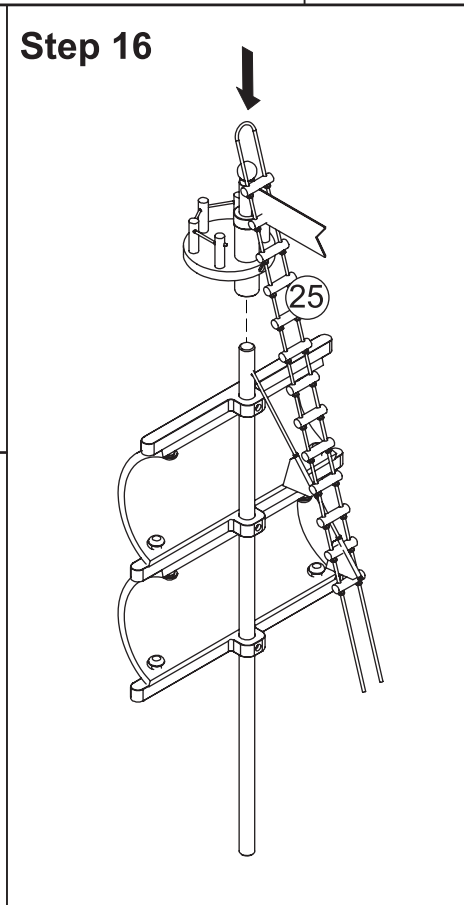
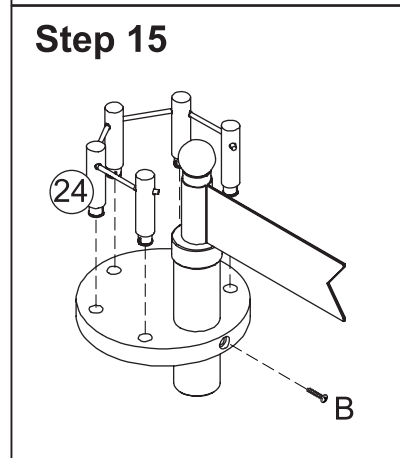
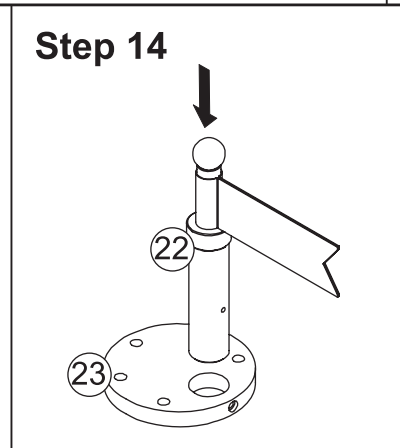
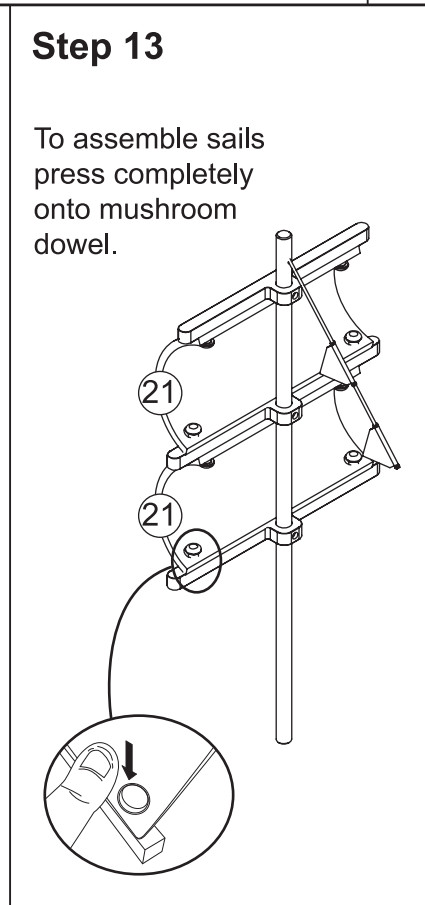
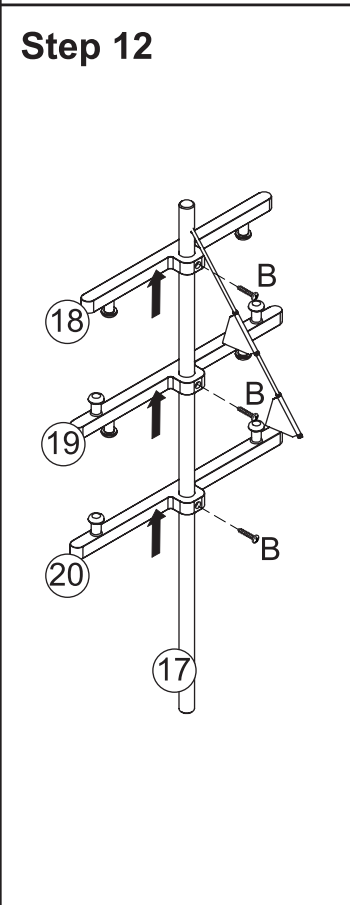
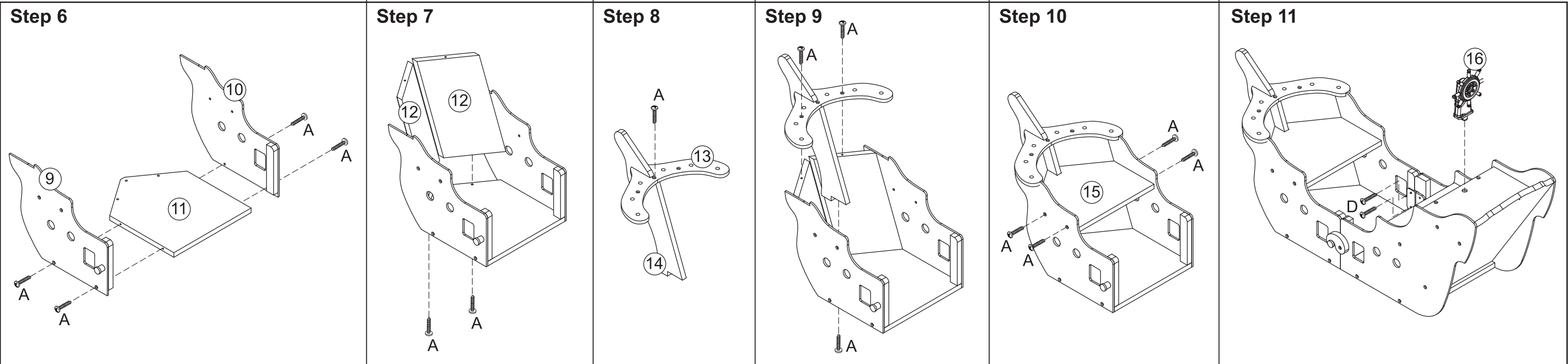

Before calling customer service, please locate the batch code number (example: 105906/65006/04) found on the bottom or back of your product.

Customer Service
1-800-933-0771
www.kidkraft.com



IMPORTANT INFORMATION - PLEASE READ FIRST

ALL OF OUR WOODEN ITEMS ARE HANDCRAFTED, HAND ASSEMBLED, AND HAND PAINTED. EACH ONE IS UNIQUE. SLIGHT IMPERFECTIONS MAY OCCUR AND ARE NOT MANUFACTURING DEFECTS.

PLEASE NOTE THAT WE DO NOT WARRANTY AGAINST THE USE OF PERMANENT MARKERS, NON-WATER-BASED PAINTS, CRAYONS, OR WASHABLE MARKERS. SOME OF THESE ITEMS CONTAIN PERMANENT COLOR DYES THAT COULD DAMAGE THE SURFACE.

CLEANING INSTRUCTIONS

CLEAN THE SURFACE USING A SLIGHTLY DAMP CLOTH AND MILD DISH WASHING LIQUID IF NECESSARY. DO NOT USE ANY CLEANING PRODUCT CONTAINING ALCOHOL OR AMMONIA. THESE WILL DULL THE SHINY SURFACE OF THE PRODUCT. FURNITURE POLISH WILL ALSO WORK TO CLEAN AND DUST OFF THE SURFACE.

WE RECOMMEND THAT YOU TEST ALL CLEANING MATERIALS ON THE UNDERSIDE OF ANY SURFACE THAT WOULD NOT BE SEEN DURING NORMAL USE OF THE PRODUCT. IF YOU HAVE QUESTIONS REGARDING THE MAINTENANCE OF THIS PRODUCT PLEASE FEEL FREE TO CALL US.

SOLE AND LIMITED WARRANTY

THIS TOY IS WARRANTED SOLELY AGAINST MANUFACTURING DEFECTS FOR A PERIOD OF 90 DAYS FROM THE DATE OF PURCHASE, WHICH RUNS ONLY TO THE ORIGINAL USER OF THE PRODUCT. IN THE EVENT OF A MANUFACTURING DEFECT, PARTS WILL BE REPLACED OR THE ENTIRE PRODUCT WILL BE REPLACED OR THE PURCHASE PRICE WILL BE REFUNDED, AT THE ELECTION OF THE MANUFACTURER. TO ACTIVATE AND PROTECT THIS WARRANTY, PRESERVE EVIDENCE OF ORIGINAL PURCHASE AND CAREFULLY INSPECT THE CONDITION OF THIS TOY. SHOULD YOU OBSERVE ANY DEFECTS, DO NOT USE THE TOY AND IMMEDIATELY NOTIFY THE MANUFACTURER. FAILURE TO DO SO SHALL CONSTITUTE MISUSE. MISUSE, IMPROPER ASSEMBLY, FAILURE TO HONOR A WARNING, FAILURE TO SUPERVISE, INSPECT OR MAINTAIN THE TOY, OR DAMAGE TO THE TOY, WHETHER INTENTIONAL OR INADVERTENT, SHALL INVALIDATE THIS WARRANTY. THIS WARRANTY GIVES YOU SPECIFIC LEGAL RIGHTS, AND YOU MAY ALSO HAVE OTHER RIGHTS WHICH VARY FROM STATE TO STATE.

TO SUBMIT A WARRANTY CLAIM PLEASE CONTACT KIDKRAFT CUSTOMER SERVICE AT 1-800-933-0771 FOR INSTRUCTIONS ON HOW TO PROVIDE PROOF OF PURCHASE AND HOW TO RETURN THE ITEM FREIGHT PRE-PAID.

CUSTOMER SERVICE 1-800-933-0771

www.kidkraft.com