











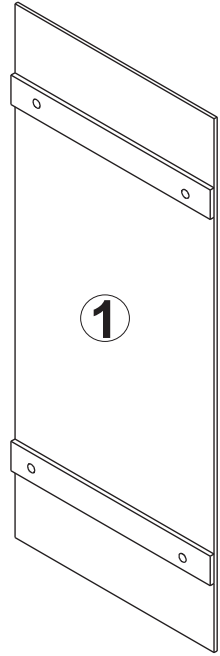
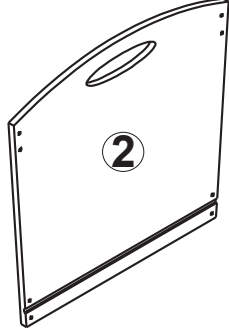
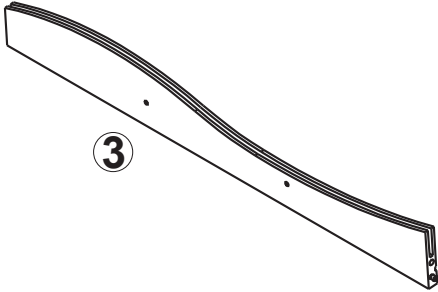
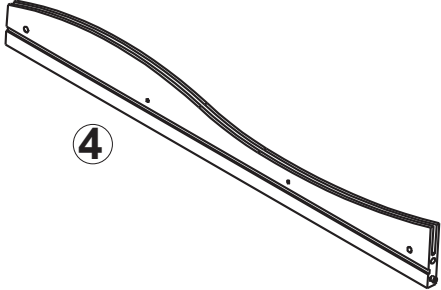

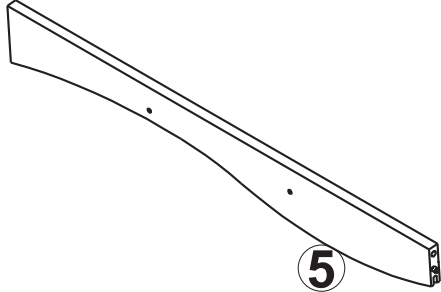
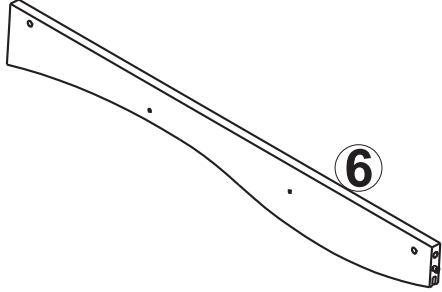
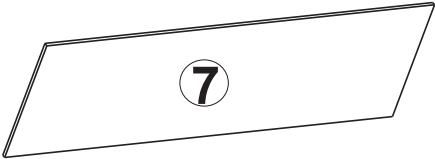
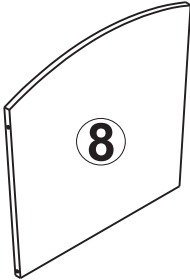
Clear Side Storage Unit

Assembly Instructions

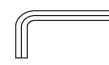
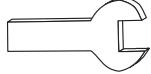
Item # 15770/15771

<p>HARDWARE</p> <p>A. Cross Dowel Bolt x 8 pcs</p> 	<p>B. Screw x 8 pcs</p> 	<p>1</p>  <p>1PC</p>	<p>2</p>  <p>2PC</p>	<p>3</p>  <p>1PC</p>	<p>4</p>  <p>1PC</p>
<p>C. Cross Dowel Nut x 8 pcs</p> 	<p>D. washer x 4 pcs</p> 	<p>5</p>  <p>1PC</p>	<p>6</p>  <p>1PC</p>	<p>7</p>  <p>1PC</p>	<p>8</p>  <p>2PC</p>
<p>E. spring washer x 4 pcs</p> 	<p>F. Wheel x 2 pcs</p> 				
<p>F1. Brake Wheel x 2 pcs</p> 	<p>G. Allen Wrench x 1 pc</p> 				
<p>Wrench x 1 pc</p> 	<p>The following tool is required for assembly :</p> 				

3+

CAUTION: Adult assembly required. Hardware contains small screws with sharp points. Keep unassembled parts out of the reach of small children.

Customer Service 1-800-933-0771



WARNING: CHOKING HAZARD
Unassembled parts may be a choking hazard to children 3 years and younger.

Clear Side Storage Unit

Assembly Instructions

Item # 15770/15771

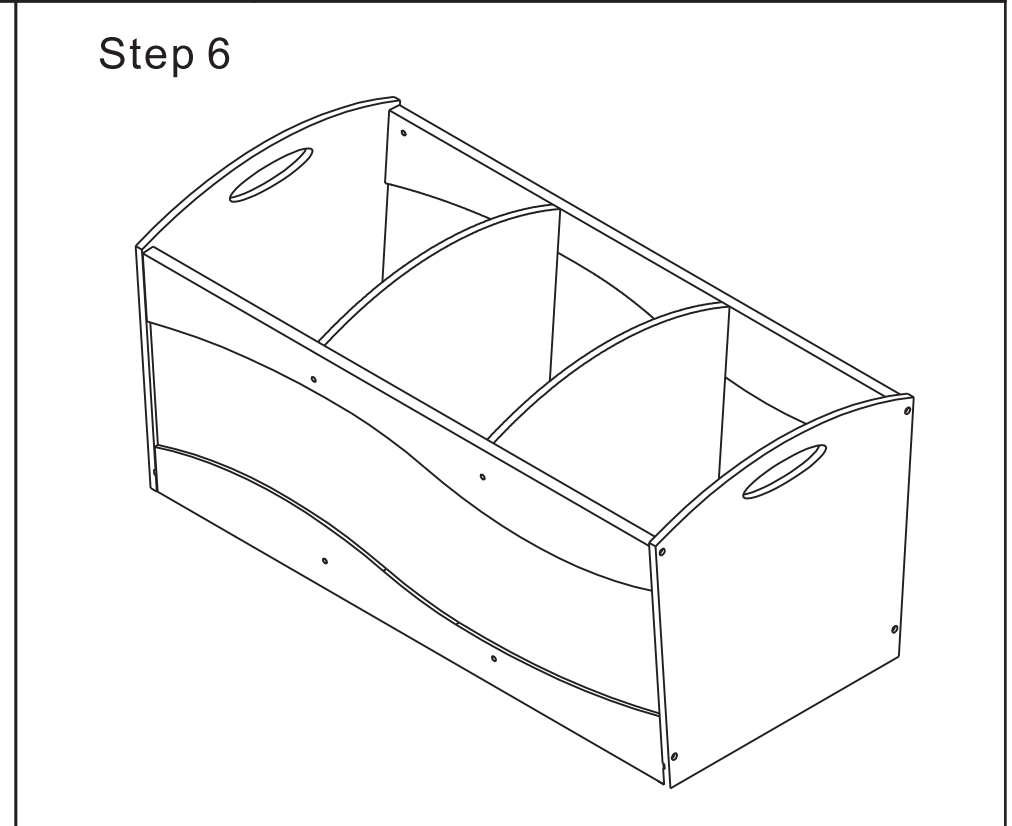
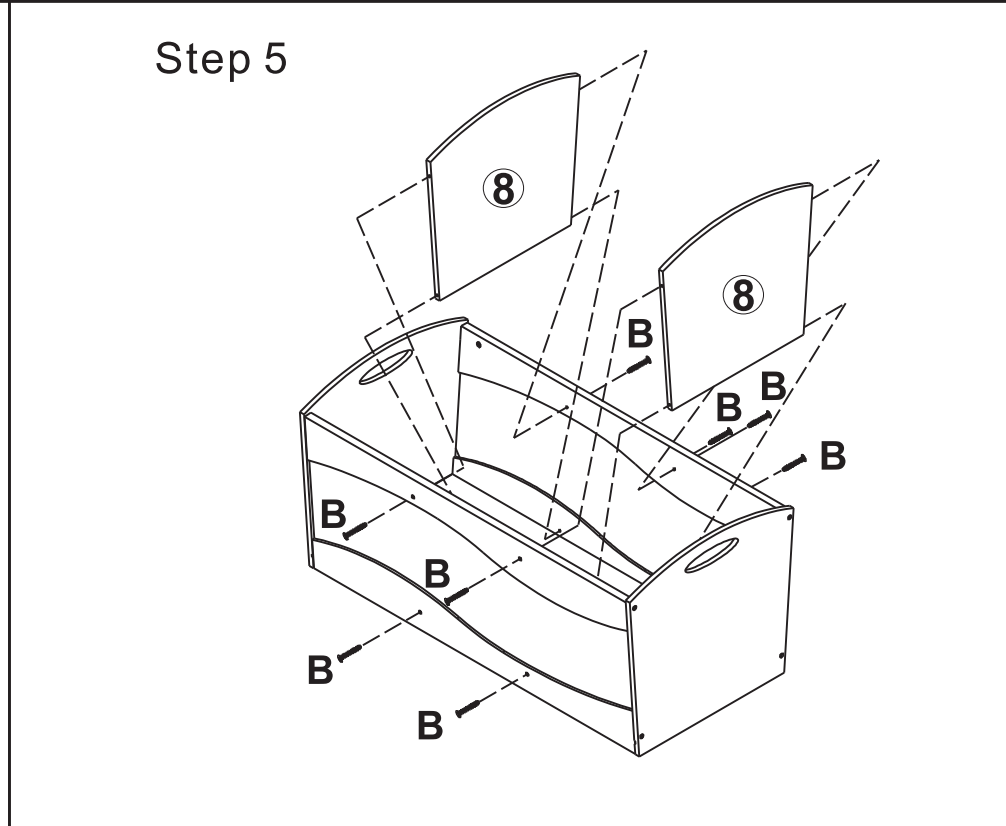
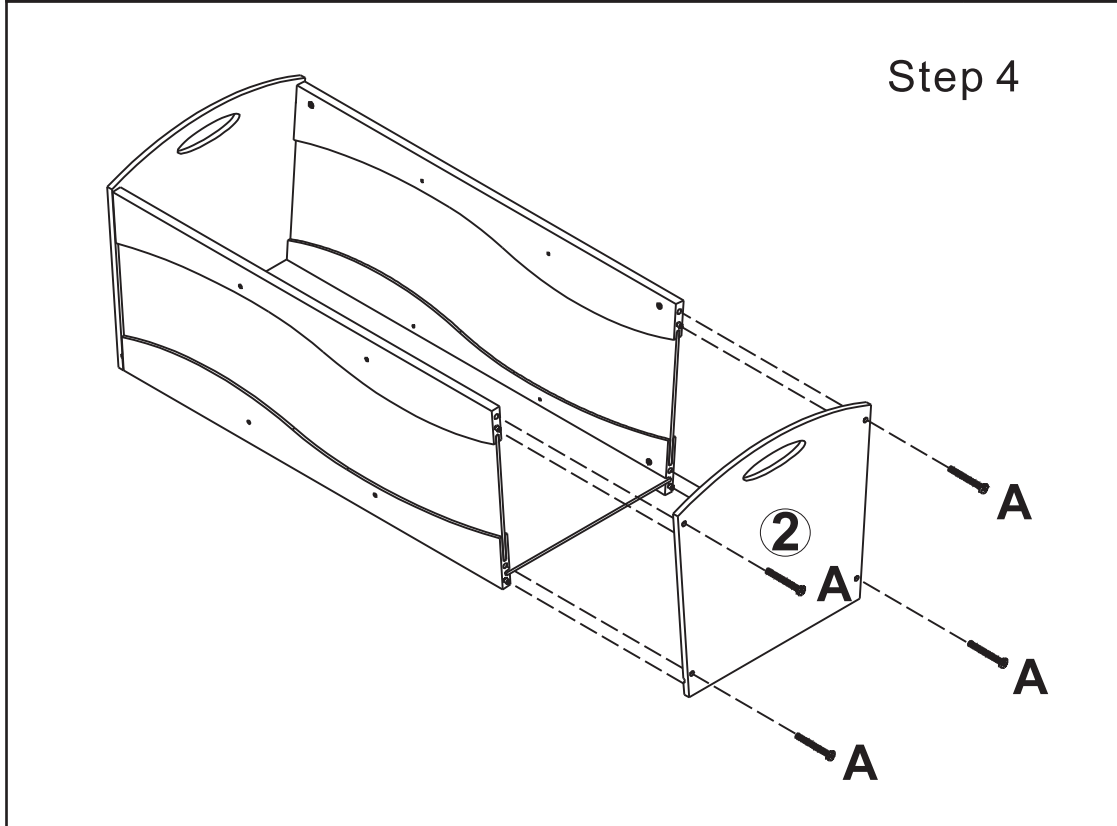
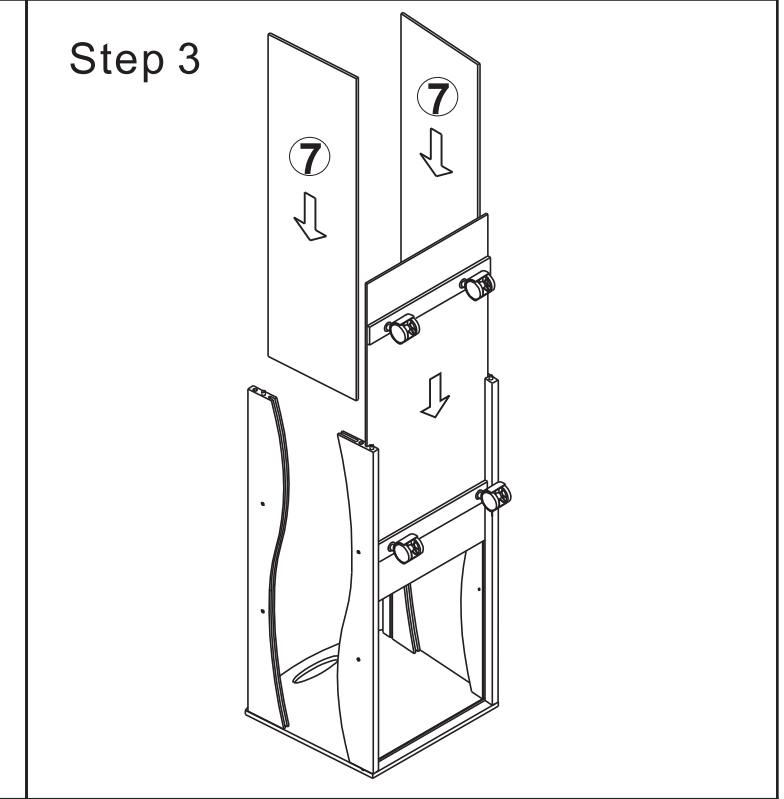
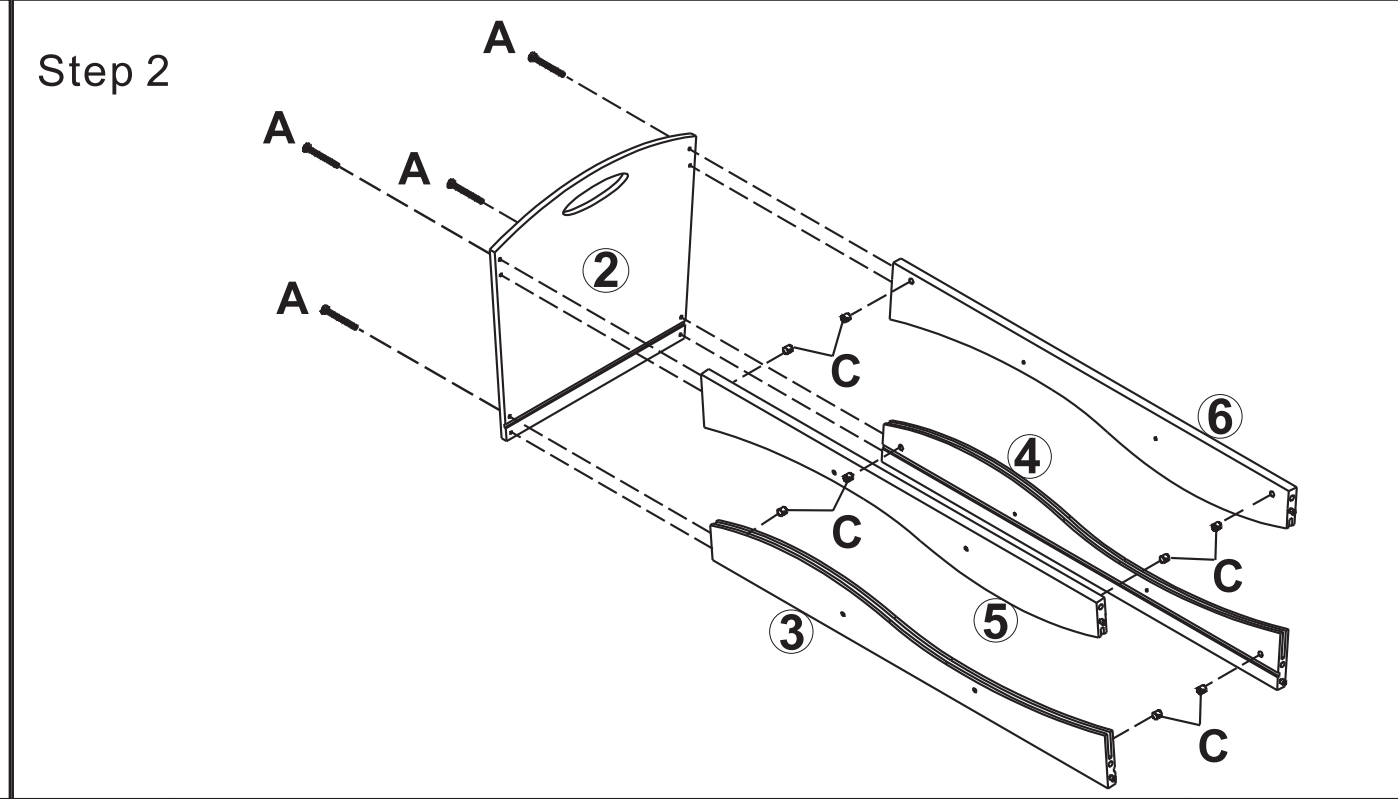
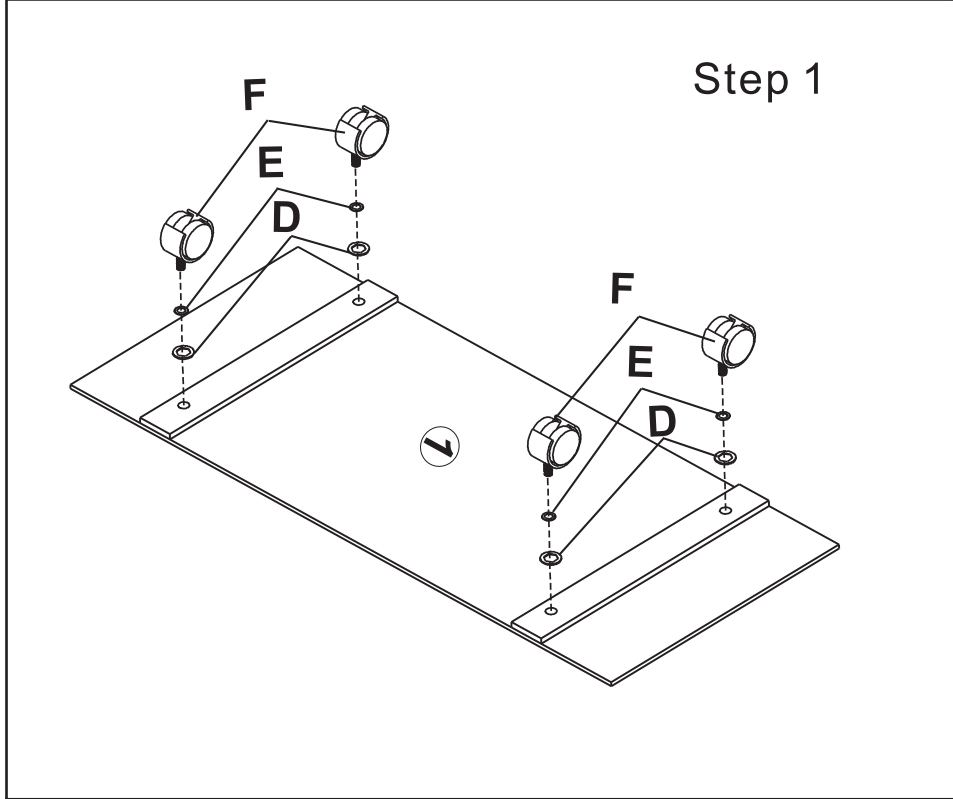

3+

CAUTION: Adult assembly required. Hardware contains small screws with sharp points. Keep unassembled parts out of the reach of small children.

Customer Service 1-800-933-0771



WARNING: CHOKING HAZARD
Unassembled parts may be a choking hazard to children 3 years and younger.



IMPORTANT INFORMATION-PLEASE READ FIRST

ALL OF OUR WOODEN ITEMS ARE HANDCRAFTED, HAND ASSEMBLED, AND HAND PAINTED. EACH ONE IS UNIQUE. SLIGHT IMPERFECTIONS MAY OCCUR AND ARE NOT MANUFACTURING DEFECTS. EACH ITEM HAS BEEN PAINTED WITH A VERY DURABLE PAINT THAT IS BOTH LEAD AND CHROMATE FREE AND SAFE FOR CHILDREN.

PLEASE NOTE THAT WE DO NOT WARRANTY AGAINST THE USE OF PERMANENT MARKERS, NON-WATER-BASED PAINTS, CRAYONS, OR WASHABLE MARKERS. SOME OF THESE ITEMS CONTAIN PERMANENT COLOR DYES THAT COULD DAMAGE THE SURFACE

CLEANING INSTRUCTIONS

CLEAN THE SURFACE USING A SLIGHTLY DAMP CLOTH AND MILD DISHWASHING LIQUID IF NECESSARY. DO NOT USE ANY CLEANING PRODUCT CONTAINING ALCOHOL OR AMMONIA. THESE WILL DULL THE SHINY SURFACE OF THE PRODUCT. FURNITURE POLISH WILL ALSO WORK TO CLEAN AND DUST OFF THE SURFACE.

WE RECOMMEND THAT YOU TEST ALL CLEANING MATERIALS ON THE UNDERSIDE OF ANY SURFACE THAT WOULD NOT BE SEEN DURING NORMAL USE OF THE PRODUCT. IF YOU HAVE QUESTIONS REGARDING THE MAINTENANCE OF THIS PRODUCT PLEASE FEEL FREE TO CALL US.

WARRANTY

IMPORTANT: EVIDENCE OF ORIGINAL PURCHASE IS REQUIRED FOR WARRANTY SERVICE.

LENGTH OF WARRANTY: 90 DAYS FROM DATE OF PURCHASE.

THIS WARRANTY COVERS DEFECTS THAT WERE A RESULT OF THE MANUFACTURERS PRODUCTION. YOU SHOULD CAREFULLY INSPECT THE CONDITION OF THE PRODUCT PRIOR TO ASSEMBLY. THIS WARRANTY IS INVALID IF THE PRODUCT IS DAMAGED OR NOT MAINTAINED AS REASONABLE OR NECESSARY.

PROCEDURE FOR OBTAINING WARRANTY SERVICES:

PLEASE CONTACT OUR CUSTOMER SERVICE REPRESENTATIVES AT 1-800-933-0771. THEY WILL INSTRUCT YOU HOW TO SEND THE PRODUCT AND PROOF OF PURCHASE FREIGHT PREPAID TO OUR ATTENTION.

1-800-933-0771