

ASSEMBLY INSTRUCTIONS

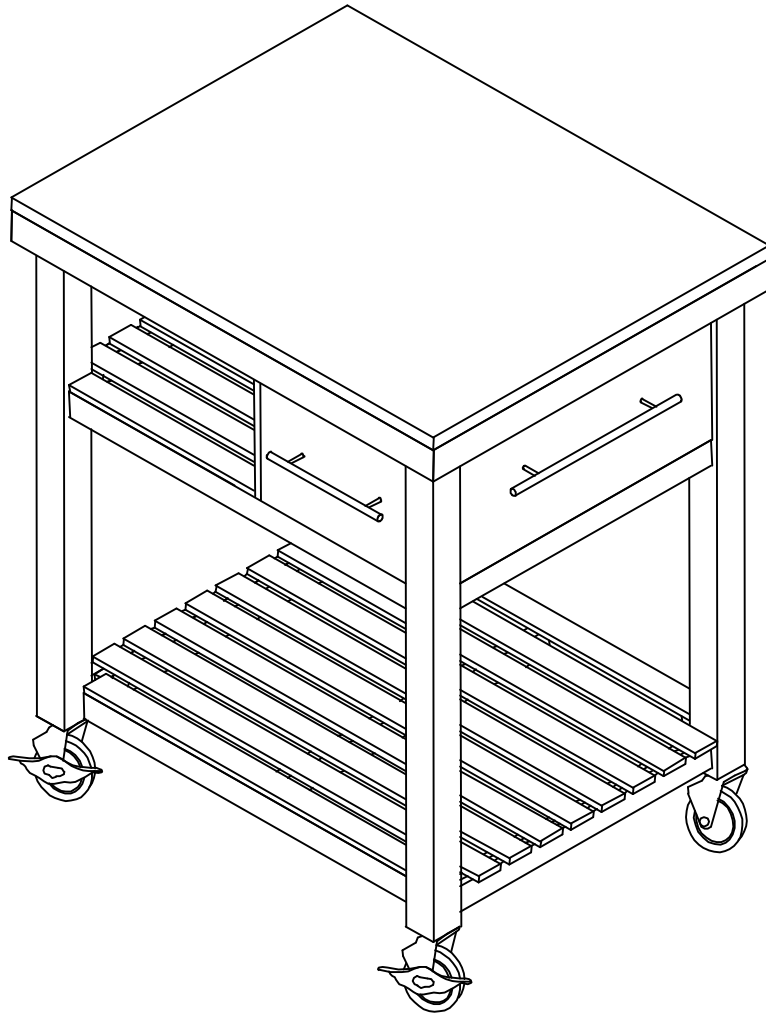

Description : CASTORED KITCHEN WORK CENTER
Item No. : WC - 3

BEFORE ASSEMBLY

Thank you for purchasing this quality product. This product has been designed for easy assembly and constructed for durability. All parts were checked prior to packaging to insure quality. Prior to beginning assembly, however, make sure all parts and hardware are included and free of obvious defect. If a part is missing or defective, please contact the store where purchased. If hardware is missing, or you need help with assembly, please call toll free 888-944-8396.

IMPORTANT NOTE:

- Place all wooden parts on a clean and smooth surface such as a rug or carpet to avoid the parts from being scratched.
- Remove all wrapping material, including staples & packing straps before you start to assemble.
- DO NOT tighten all screws and bolts until completely assembled.
- Keep all hardware parts out of reach of children.

ASSEMBLY TOOLS REQUIRED

NOT INCLUDED







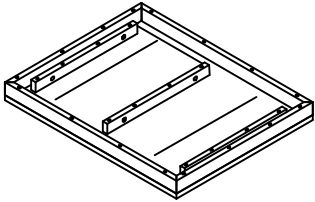
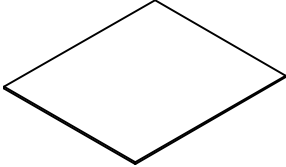
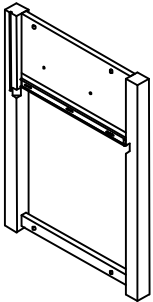
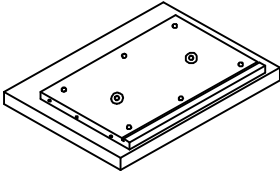
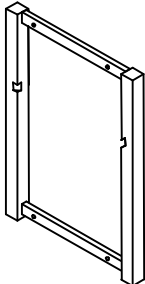
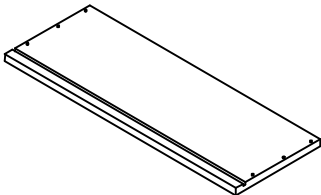
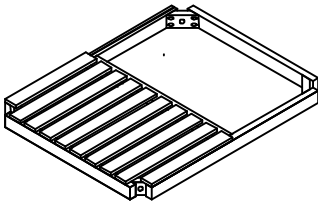
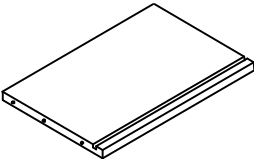
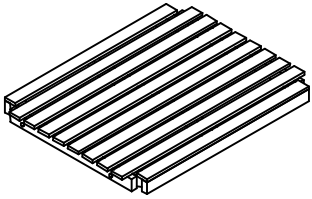
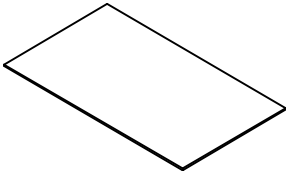
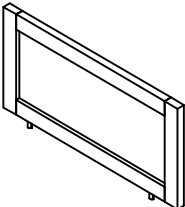



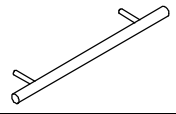

PART LIST

When unpacking, please be careful not to discard any parts with the packaging. Before continuing, please make sure you have the following parts:

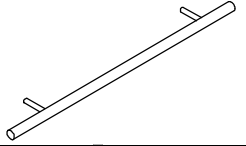
NO	Description	Qty	Sketch	NO	Description	Qty	Sketch
A	Top	1		G	Back panel	1	
B	Side frame (right)	1		H	Drawer front	1	
C	Side frame (left)	1		I	Drawer side (L & R)	2	
D	Shelf frame	1		J	Drawer back	1	
E	Bottom frame	1		K	Drawer bottom	1	
F	Partition	1					

HARDWARE LIST

When unpacking, please be careful not to discard any parts with the packaging. Before continuing, please make sure you have all of the following hardware :

NO	Description	Qty	Sketch	NO	Description	Qty	Sketch
1	Long bolt (M6x45mm)	4		7	Panheadscrew (M4x30mm)	4	
2	Short bolt (M6x35mm)	10		8	Drawer handle (short)	1	
3	Lock Washer (Φ6.5 x 13mm)	14		9	Side handle (long)	1	
4	Flat Washer (Φ6.5 x 19mm)	14		10	Castor	2	
5	Allen key (M4)	1		11	Lock castor	2	
6	Screw (M4x30mm)	14		12	Wrench (19mm)	1	

STEP 1

Carefully place the top (A) on the soft surface to avoid damaging the top.

Attach right side frame (B), left side frame (C) to the top (A) with bolts (2) and washers (3) and (4). Tighten with Allen key (5).

Attach side handle (9) to right side frame (B) with screws (7). Tighten with a screwdriver.

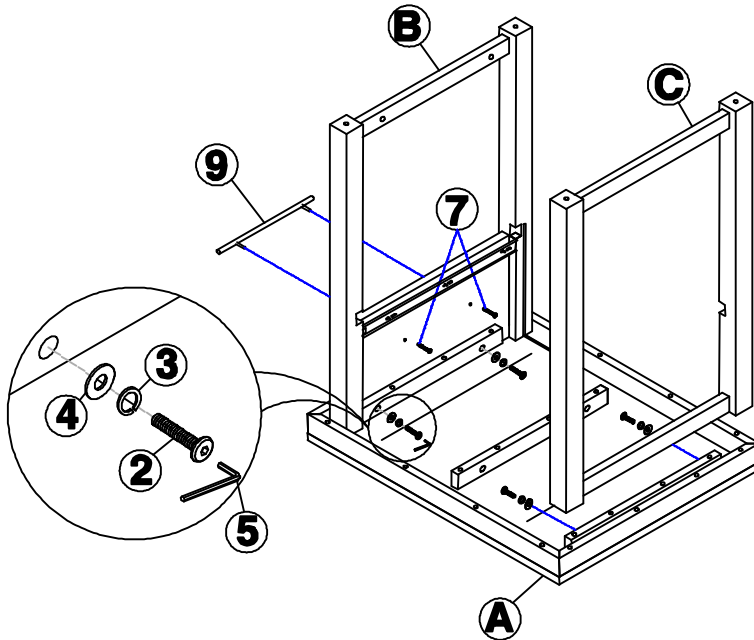

STEP 2

Attach partition (F) to the top (A) with bolts (2) and washers (3) and (4). Tighten with Allen key (5).

Insert back panel (G) into grooves of partition (F) and right side frame (B).

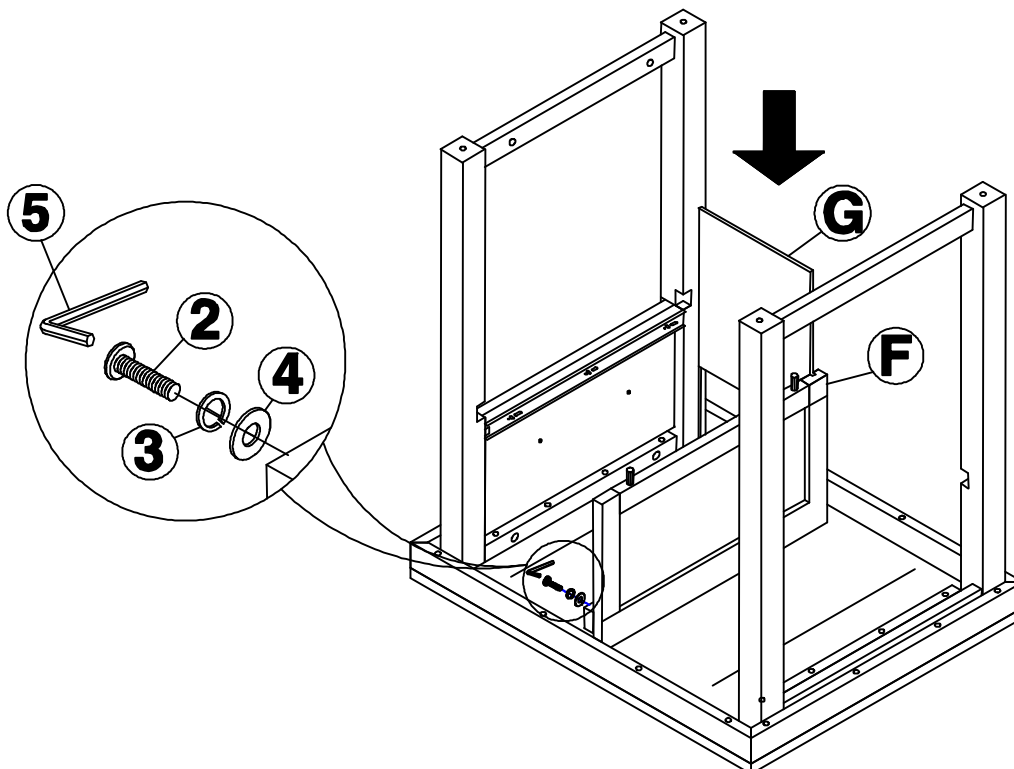

STEP 3

Attach shelf frame (D) to the partition (F) with screws (6). Tighten with a screwdriver.
Attach shelf frame (D) to right side frame (B) and left side frame (C) with bolts (1) and washers (3) and (4). Tighten with Allen key (5).

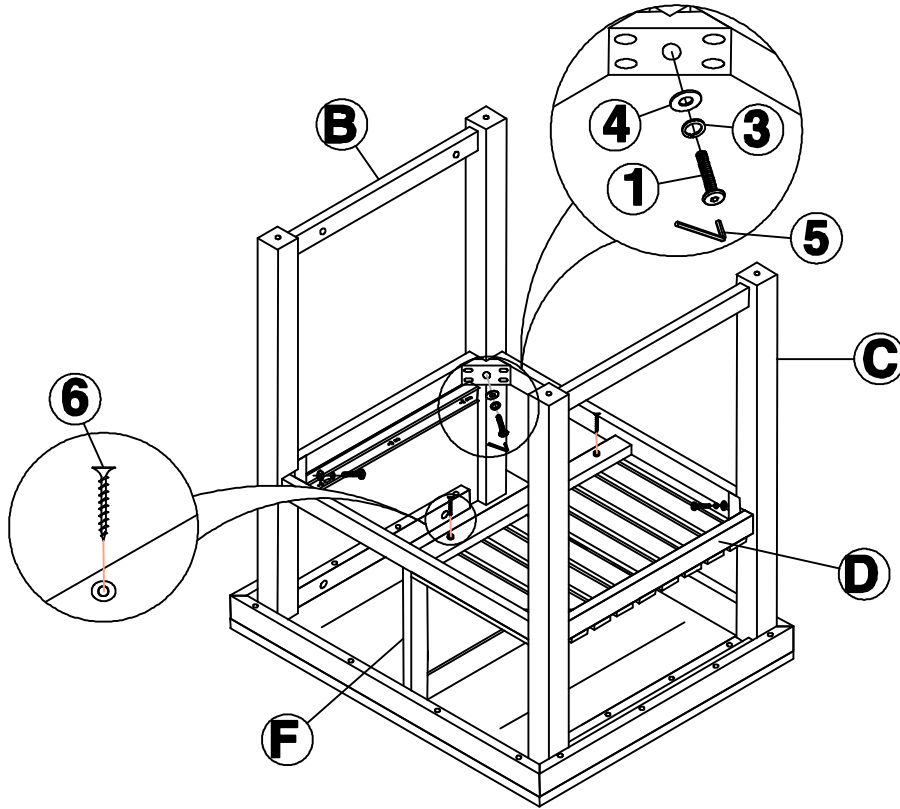

STEP 4

Attach bottom frame (E) to right side frame (B) and left side frame (C) with bolts (2) and washers (3) and (4). Tighten with Allen key (5).

Attach castors (10) and lock castors (11) to the bottom of legs as shown below. Tighten with the wrench (12).

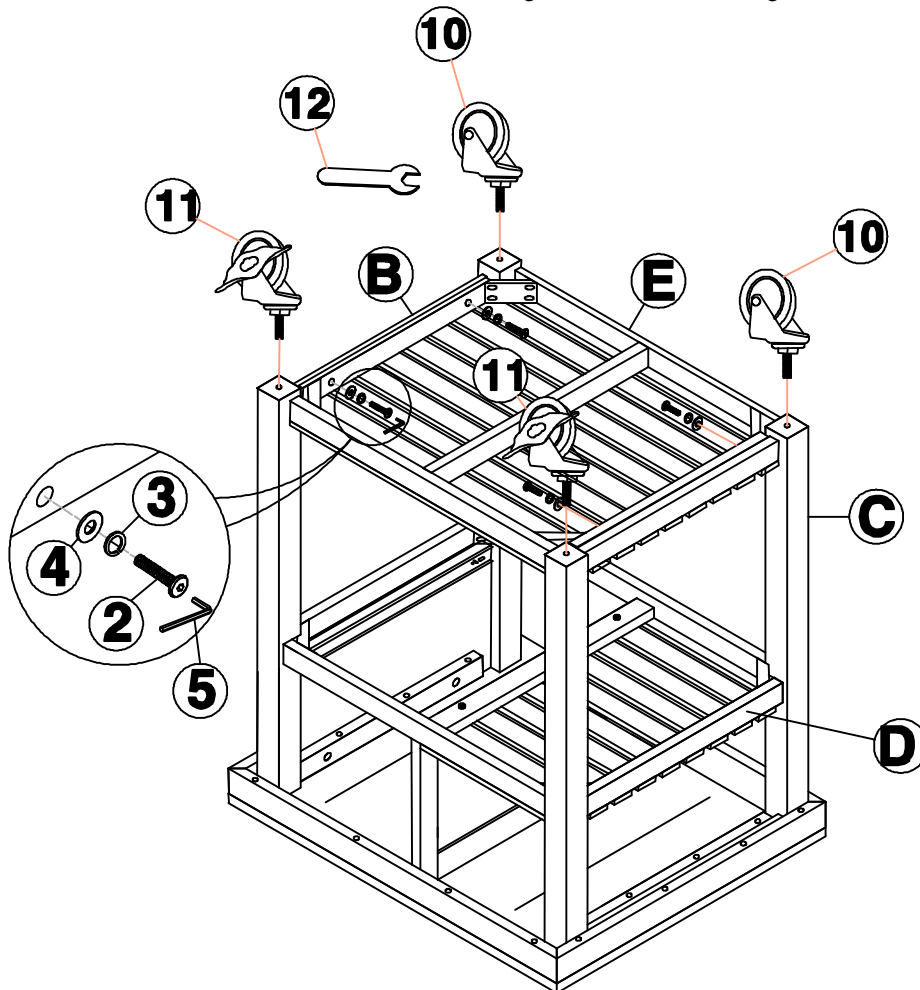

STEP 5

Attach a drawer side (I) to drawer front (H) and drawer back (J) with screws (6). Tighten with a screwdriver. Insert drawer bottom (K) into the grooves at bottom of drawer side (I), drawer front (H) and drawer back (J).

Attach the other drawer side (I) to drawer front (H) and drawer back (J) with screws (6). Tighten with a screwdriver.

Attach handle (8) to drawer front (H) with screws (7) as shown below. Tighten with a screwdriver.

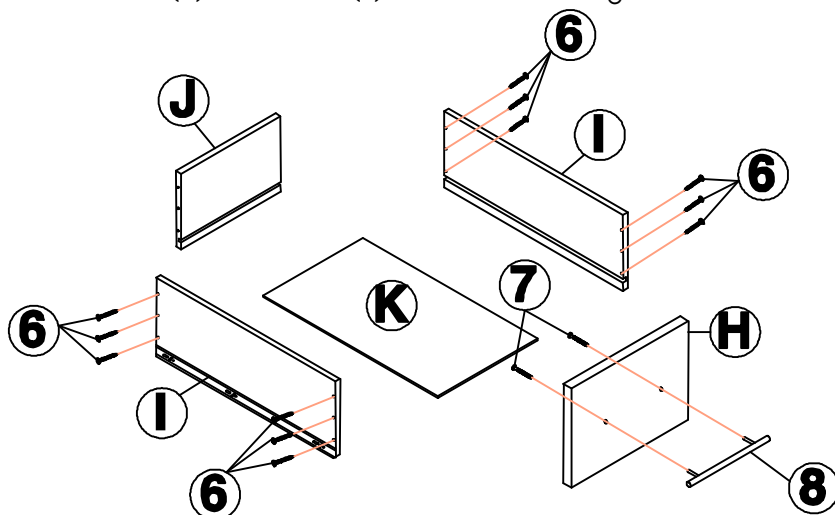

STEP 6

Carefully put the drawer (from step 5) into the unit.

