

# ASSEMBLY INSTRUCTIONS

---

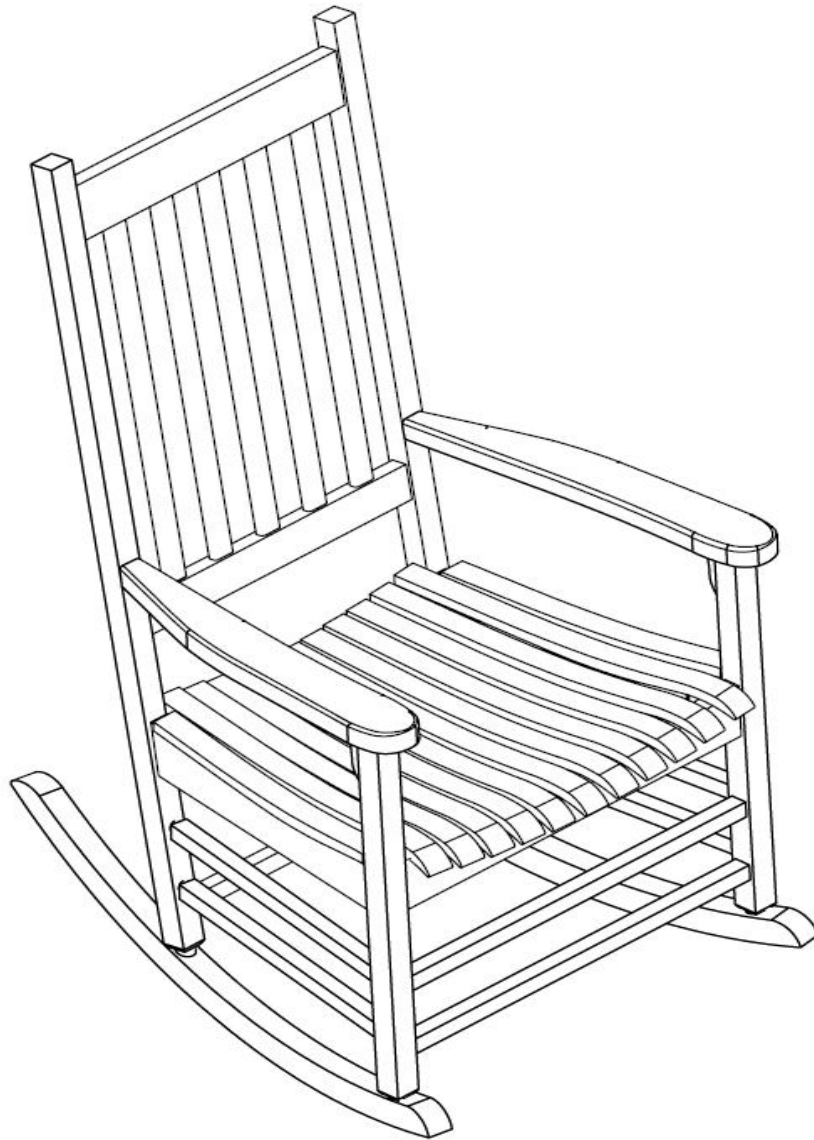

---

Description : PORCH ROCKER  
Item No. : R-51864

ITEM NO : R-51864  
REVISED JUL 22, 2013

Printed in Vietnam

## BEFORE ASSEMBLY

Thank you for purchasing this quality product. This product has been designed for easy assembly and constructed for durability. All parts were checked prior to packaging to insure quality. Prior to beginning assembly, however, make sure all parts and hardware are included and free of obvious defect. If a part is missing or defective, please contact the store where purchased. If hardware is missing, or you need help with assembly, please call toll free 888-944-8396.

### IMPORTANT NOTE:

- Place all wooden parts on a clean and smooth surface such as a rug or carpet to avoid the parts from being scratched.
- Remove all wrapping material, including staples & packing straps before you start to assemble.
- DO NOT tighten all screws and bolts until completely assembled.
- Keep all hardware parts out of reach of children.





### ASSEMBLY TOOLS REQUIRED



NOT INCLUDED

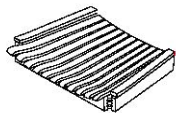
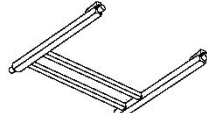
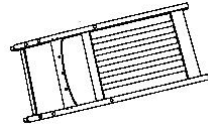
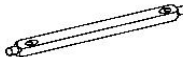

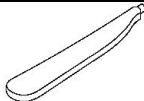

## PART LIST

When unpacking, please be careful not to discard any parts with the packaging. Before continuing, please make sure you have the following parts:

NO	Description	Qty	Sketch	NO	Description	Qty	Sketch
A	Seat	1		B	Front leg frame	1	
C	Back	1		D	Long stretcher	2	
E	Short stretcher	2		F	Left arm	1	
G	Right arm	1		H	Runner	2	

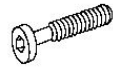
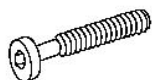
## HARDWARE LIST

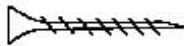
When unpacking, please be careful not to discard any parts with the packaging. Before continuing, please make sure you have all of the following hardware:

NO	Description	Qty	Sketch	NO	Description	Qty	Sketch
1	Short Bolt (M8 x 35mm)	1		2	Long Bolt (M8 x 70mm)	8	
3	Flat Washer ( $\phi$ 8.5x19mm)	9		4	Lock Washer ( $\phi$ 8.5 X 14mm)	9	
5	Long screw (M4 x45mm)	16		6	Allen key (4x80mm)	1	

## STEP 1

Attach seat (A) to back (C) with bolts (1) and (2), and washers (3) and (4) as shown below. Tighten with Allen key (6).

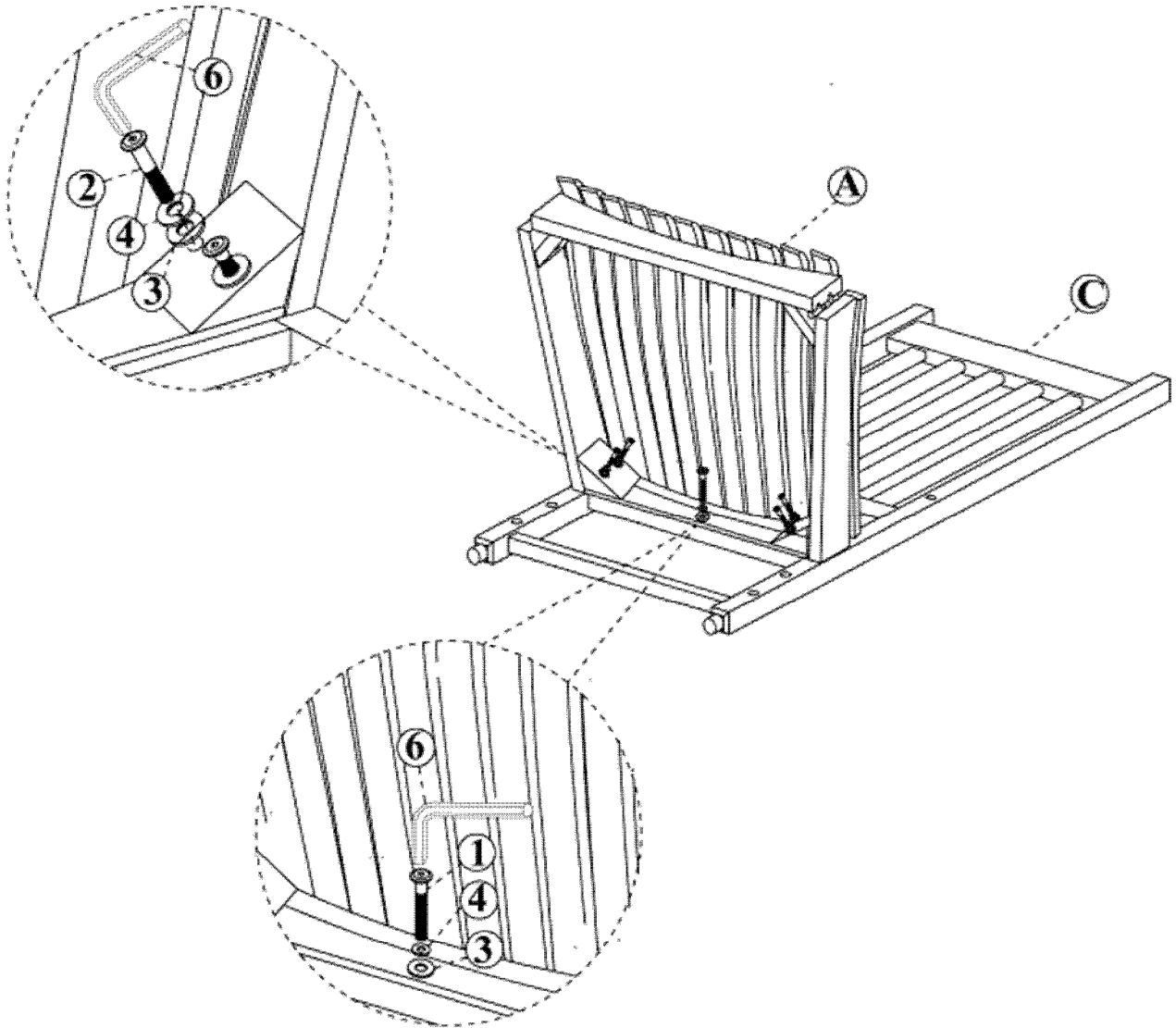

## STEP 2

Attach front leg frame (B) to seat (A) with bolts (2), and washers (3) and (4) as shown below. Tighten with Allen key (6).

Attach stretchers (D) and (E) to front and back legs with screws (5). Tighten with a screwdriver.

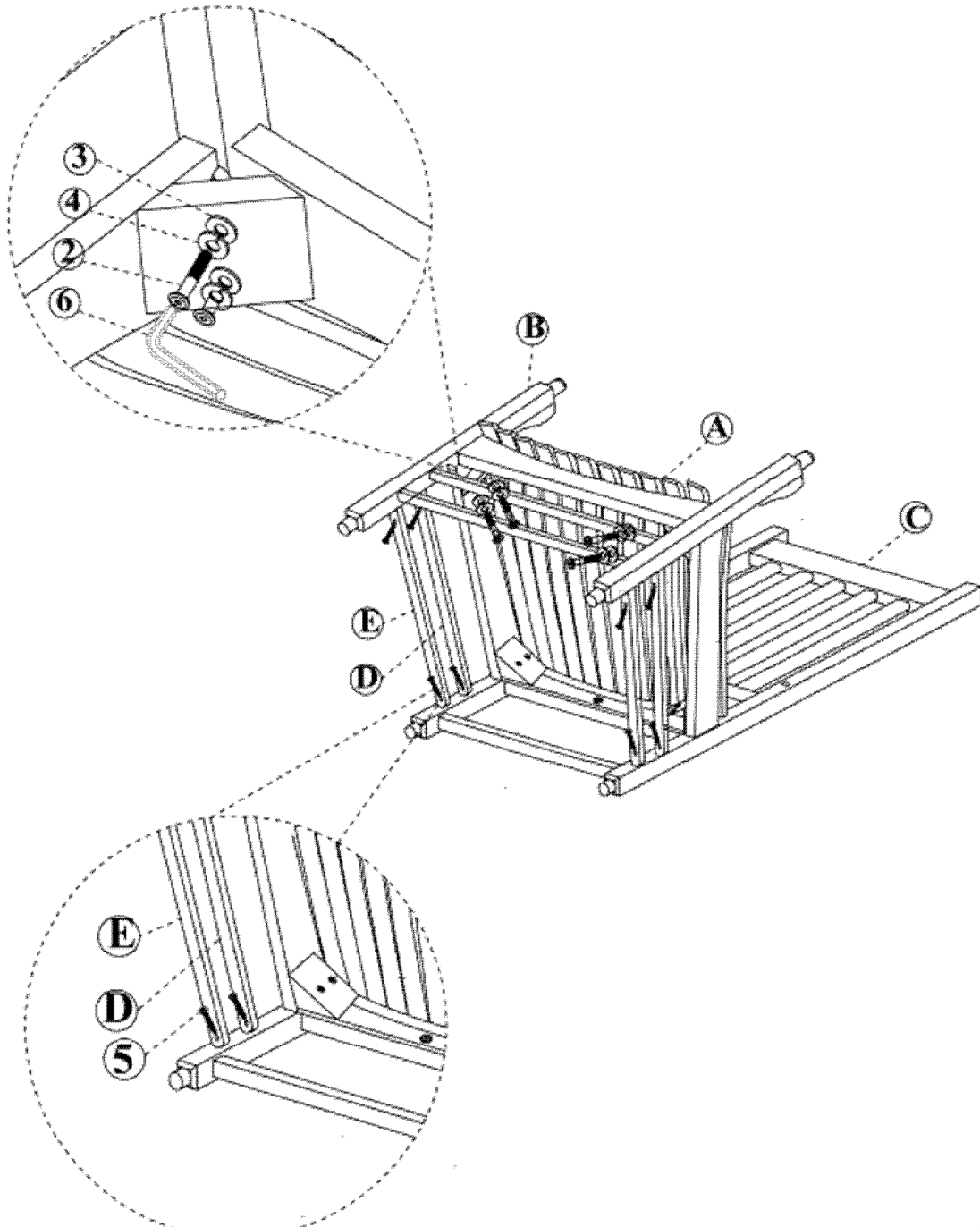

### STEP 3

Attach arms (F) and (G) to front and back legs with screws (5) as shown below. Tighten with the screwdriver.

Attach runners (H) to bottom of front and back legs with screws (5) as shown below. Tighten with the screwdriver.

