

# ASSEMBLY INSTRUCTIONS

---

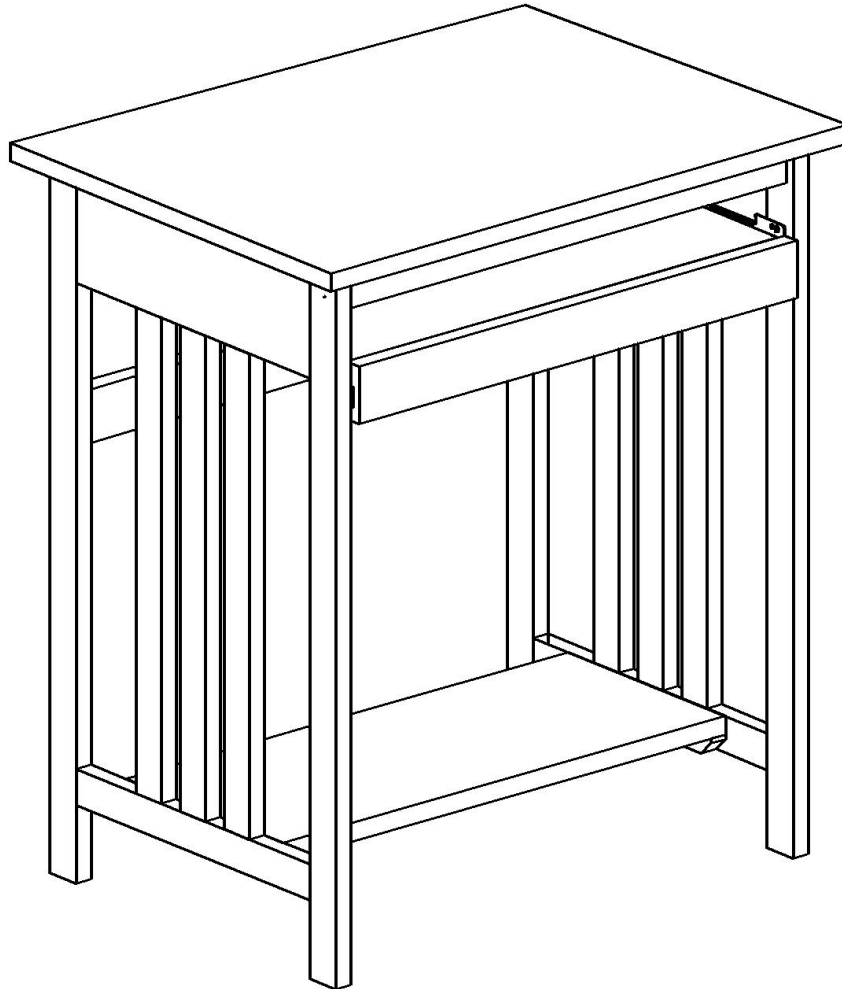

---

Description : MISSION COMPUTER STAND  
Item No. : 273

ITEM NO : 273  
REVISED MAY 15, 2014

Printed in Vietnam

## BEFORE ASSEMBLY

Thank you for purchasing this quality product. This product has been designed for easy assembly and constructed for durability. Please take the time to read and follow the assembly instructions carefully.

Be sure to check all packing material carefully for small parts which may have come loose inside the carton during shipment. Please separate, identify, and count all parts and metal hardware. Compare with part list to be sure all parts are present. If hardware is missing or you have difficulty assembling this product, please **call** Toll Free: 1-888-944-8396.

**IMPORTANT NOTE:**

- Place all wooden parts on a clean and smooth surface such as a rug or carpet to avoid the parts from being scratched.
- Remove all wrapping material, including staples & packing straps before you start to assemble.
- DO NOT tighten all screws and bolts until completely assembled.
- Keep all hardware parts out of reach of children.





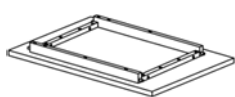
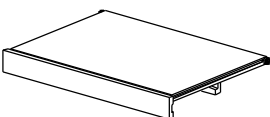
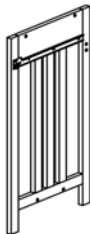
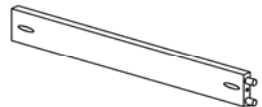
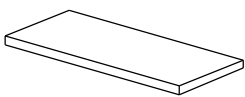
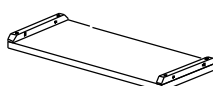

## PART LIST

When unpacking, please be careful not to discard any parts with the packaging. Before continuing, please make sure you have the following par

NO	Description	Qty	Sketch	NO	Description	Qty	Sketch
A	Top	1		D	Keyboard tray	1	
B	Side frame (L-R)	2		E	Center rail	1	
				F	Slide in panel	1	
C	Bottom shelf	1					

# HARDWARE LIST

When unpacking, please be careful not to discard any parts with the packaging. Before continuing, please make sure you have all of the following hardware:

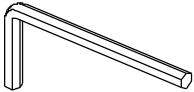
NO	Description	Qty	Sketch	NO	Description	Qty	Sketch
1	Long bolt ( $\Phi 6 \times 35 \text{mm}$ )	8		2	Flat washer ( $\Phi 6.5 \times \Phi 19 \text{mm}$ )	8	
3	Spring washer ( $\Phi 6.5 \times \Phi 13 \text{mm}$ )	8		4	Wood screw M4x35mm	2	
5	Allen key (M4x70mm)	1					

## STEP 1

Attach center rails (E) and side frames (B) with the screws (4) as shown below. Tighten with a Screwdriver.

Attach the top (A) to the side frames (B) with the bolts (1), and washers (2) and (3) as shown below. Tighten with Allen key (5).

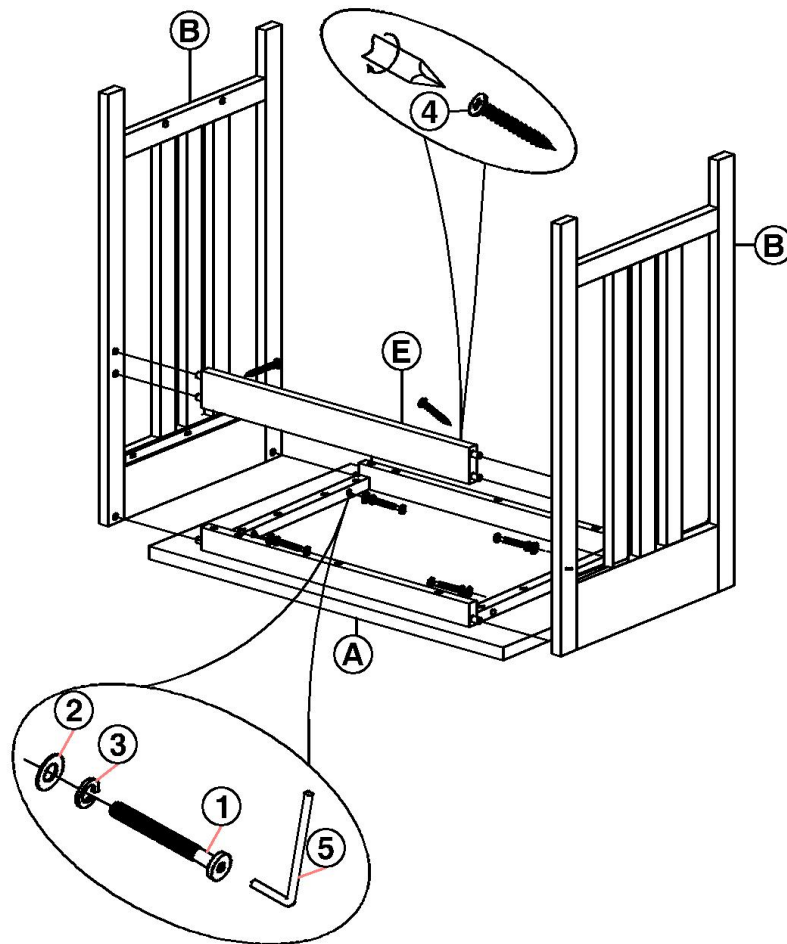

## STEP 2

Attach the bottom shelf (C) with bolts (1), and washers (2) and (3) as shown below. Tighten with the Allen key (5)

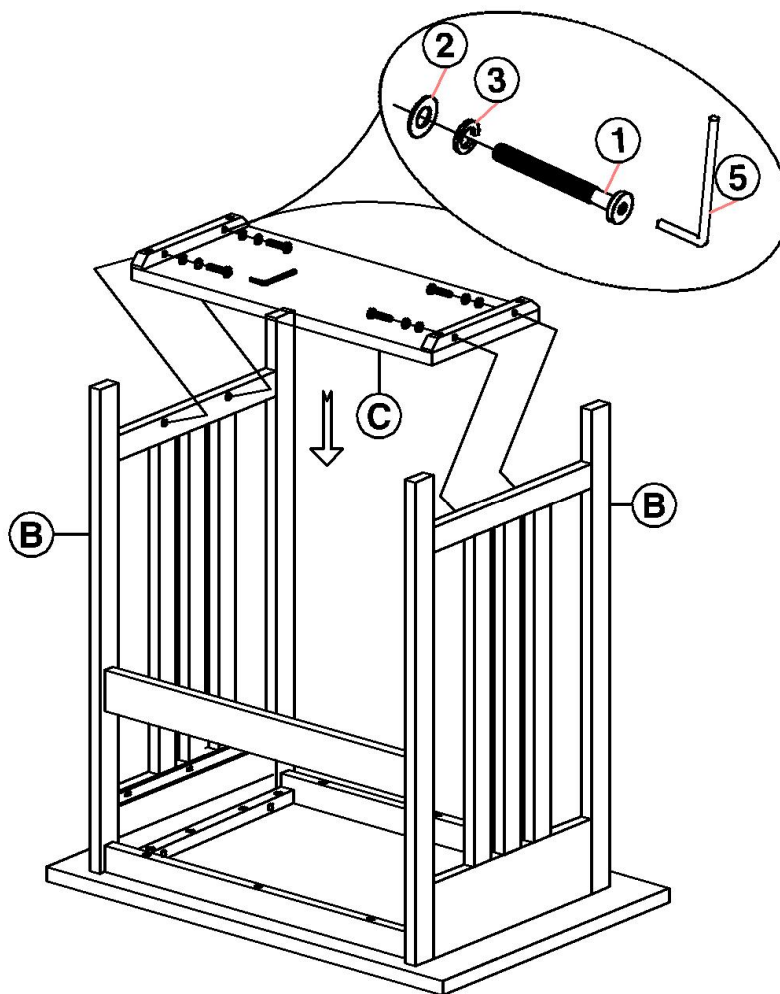

### STEP 3

Insert the keyboard tray (D) into the unit as shown below.

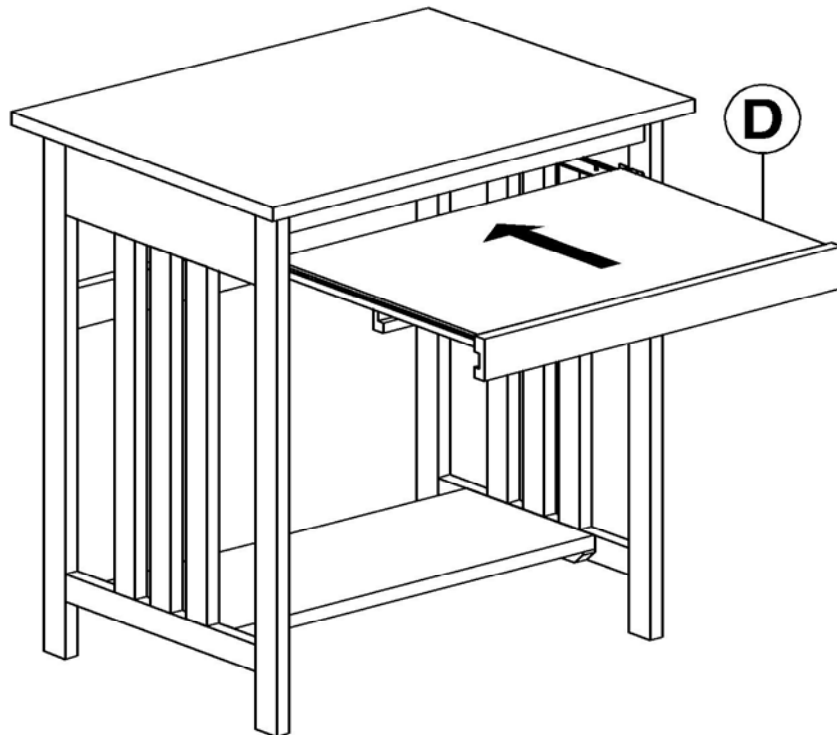

### STEP 4

Slide panel (F) into the grooves underneath the keyboard tray (D) as shown below.

