

ASSEMBLY INSTRUCTIONS

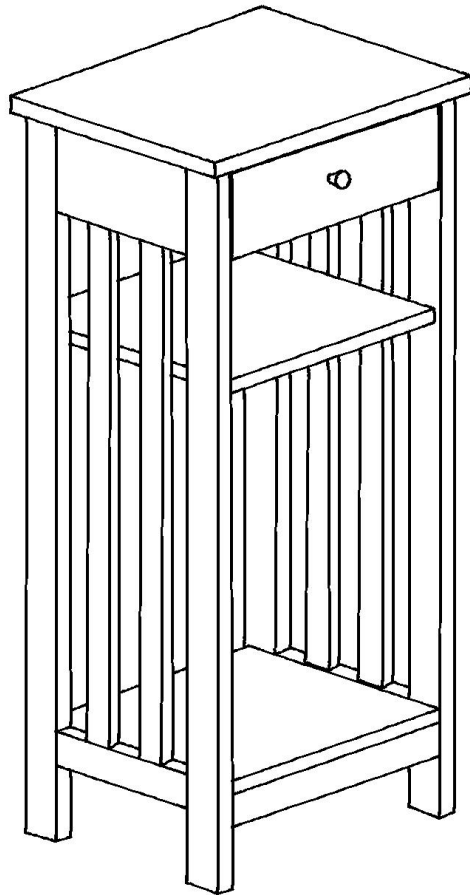

Description : MISSION TELEPHONE STAND
Item No. : 3072

BEFORE ASSEMBLY

Thank you for purchasing this quality product. This product has been designed for easy assembly and constructed for durability. All parts were checked prior to packaging to insure quality. Prior to beginning assembly, however, make sure all parts and hardware are included and free of obvious defect. If a part is missing or defective, please contact the store where purchased. If hardware is missing, or you need help with assembly, please call toll free 888-944-8396.

IMPORTANT NOTE:







- Place all wooden parts on a clean and smooth surface such as a rug or carpet to avoid the parts from being scratched.
- Remove all wrapping material, including staples & packing straps before you start to assemble.
- DO NOT tighten all screws and bolts until completely assembled.
- Keep all hardware parts out of reach of children.

ASSEMBLY TOOLS REQUIRED

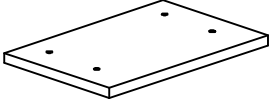
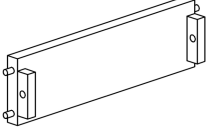
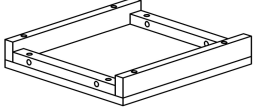
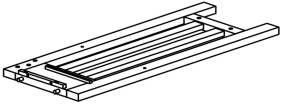

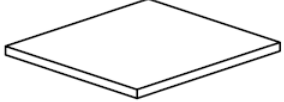





PART LIST

When unpacking, please be careful not to discard any parts with the packaging. Before continuing, please make sure you have the following parts:

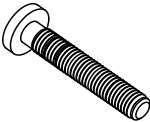
NO	Description	Qty	Sketch	NO	Description	Qty	Sketch
A	TOP	1		B	APRON	1	
C	BOTTOM SHELF	1		D	SIDE FRAME (L&R)	2	
E	DRAWER BOTTOM PANEL	1		F	ADJUSTABLE SHELF	1	
J	DRAWER FRONT	1		H	DRAWER SIDE	2	
I	DRAWER BACK	1					

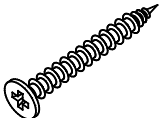
HARDWARE LIST

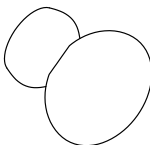
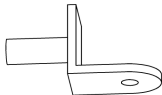
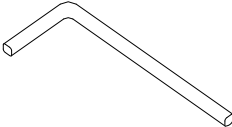
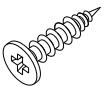
When unpacking, please be careful not to discard any parts with the packaging. Before continuing, please make sure you have all of the following hardware:

NO	Description	Qty	Sketch	NO	Description	Qty	Sketch
1	BOLT (M6x35mm)	6		2	FLAT WASHER (Φ6.5x19mm)	6	
3	LOCK WASHER (Φ6.5x13mm)	6		4	MEDIUM SCREW (M4x30mm)	12	
5	PAN HEAD SCREW (M4x30mm)	1		6	WOODEN KNOB (φ38mm)	1	
7	BRACKET	4		8	ALLEN KEY (4x80mm)	1	
9	SHORT SCREW (M3.5x15mm)	5		10	DRAWER STOPPER	1	

STEP 1

Attach apron (B) and bottom self (C) to side frames (D) with bolts (1), and washer (2) and (3) as shown below. Tighten with allen key (8).

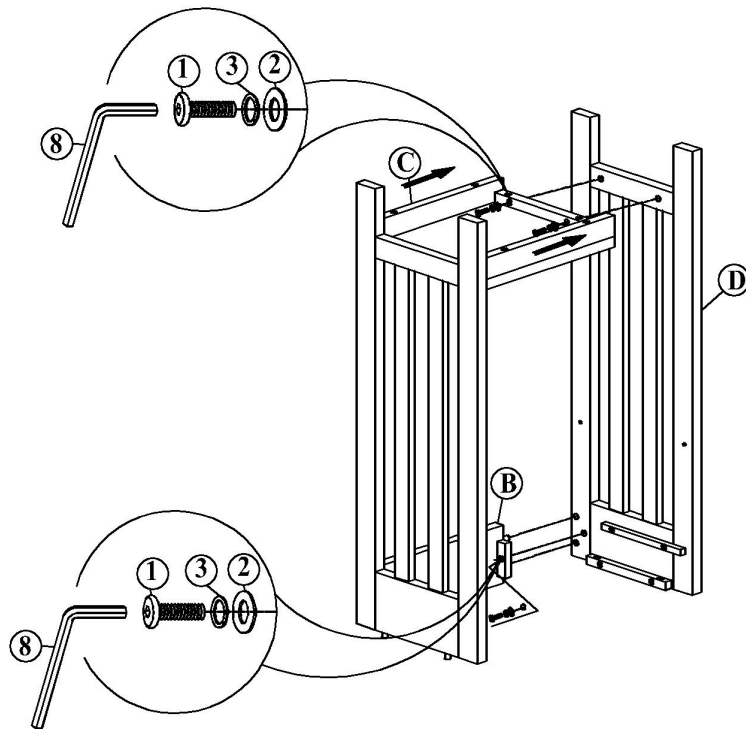

STEP 2

Attach the top (A) to the unit with screws (4) as shown below. Tighten with a screwdriver.

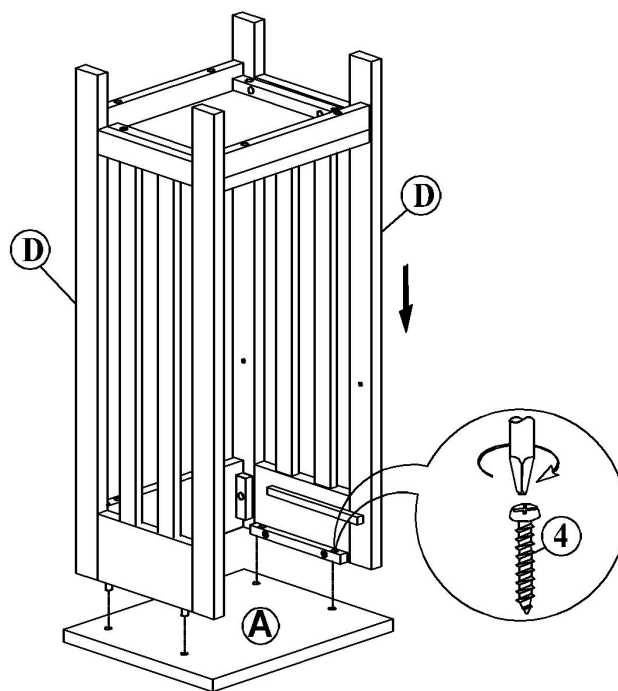

STEP 3

Attach the drawer stopper (10) to the top (A) with screw (9). Tighten with a screwdriver.

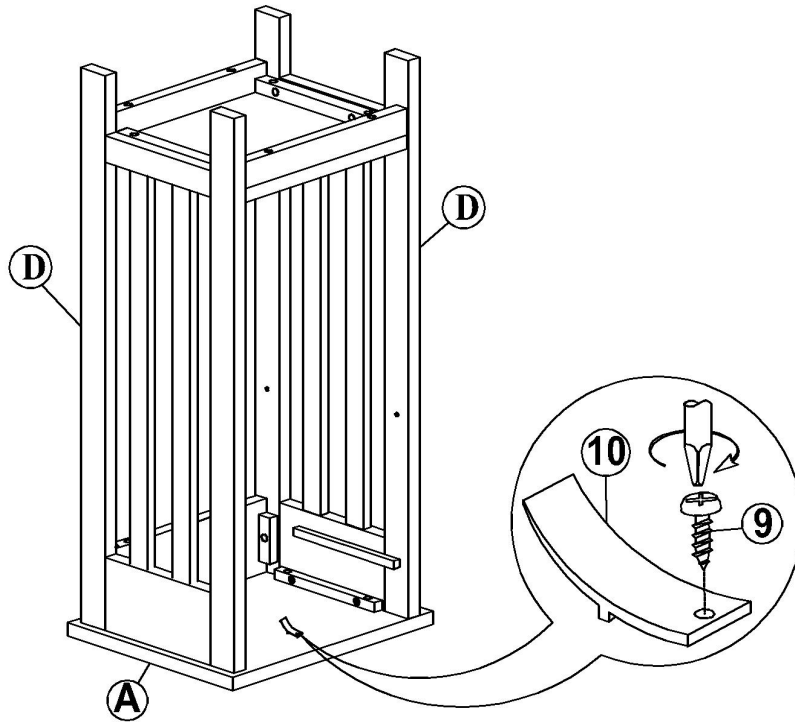

STEP 4

Attach drawer sides (H) to the drawer front (J) with screws (4) as shown below. Tighten with a screwdriver.

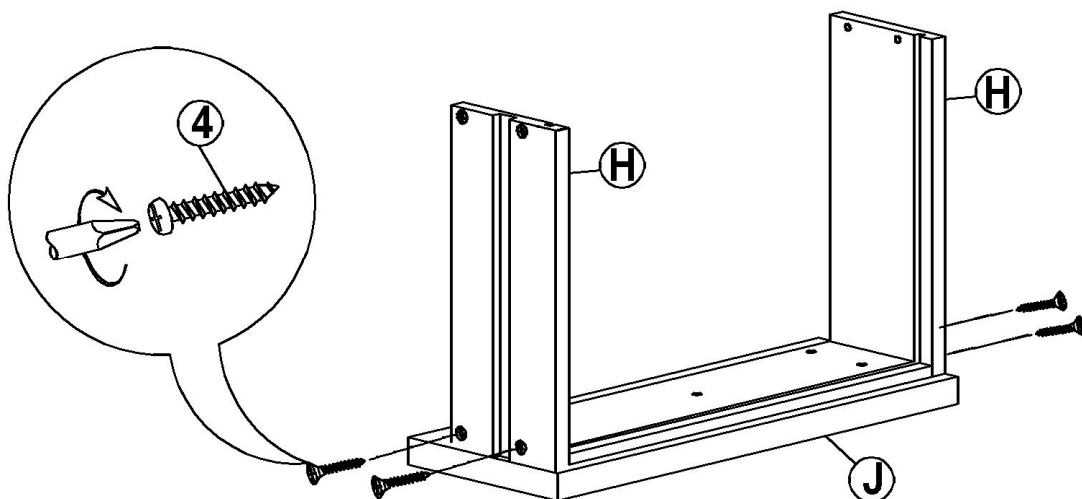

STEP 5

Slide the drawer bottom panel (E) into the grooves as shown below.

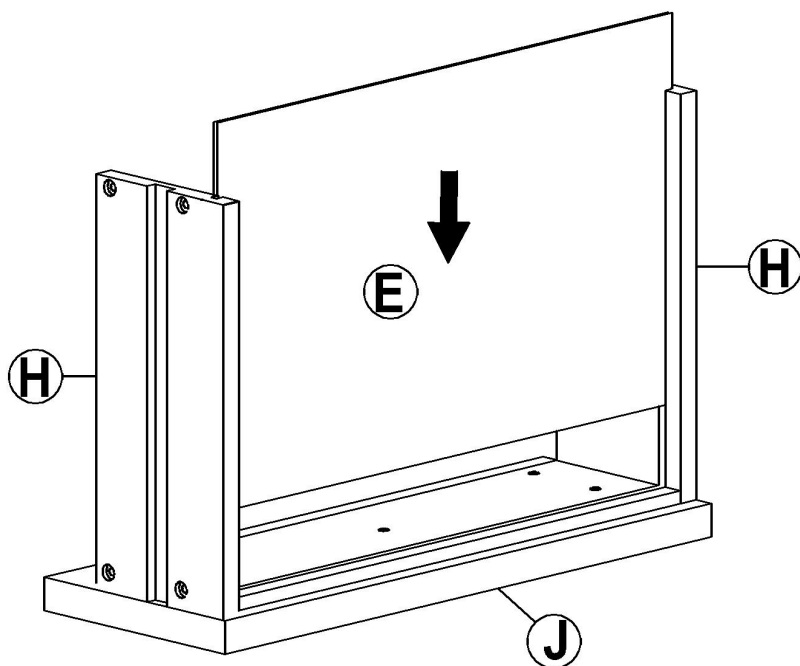

STEP 6

Attach the drawer back panel (I) to the drawer with screws (4). Tighten with a screwdriver.

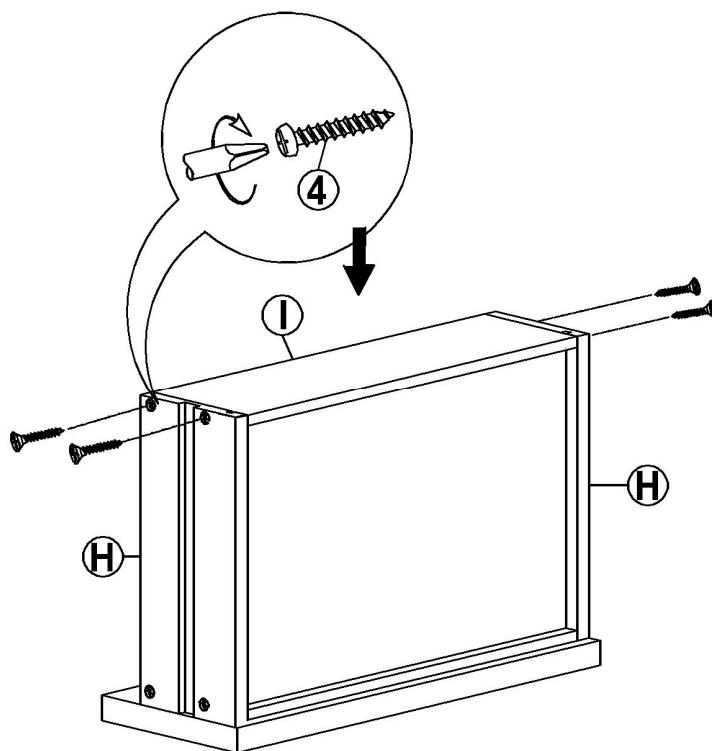

STEP 7

Attach the knob (6) to the drawer front with pan head screw (5). Tighten with a screwdriver.

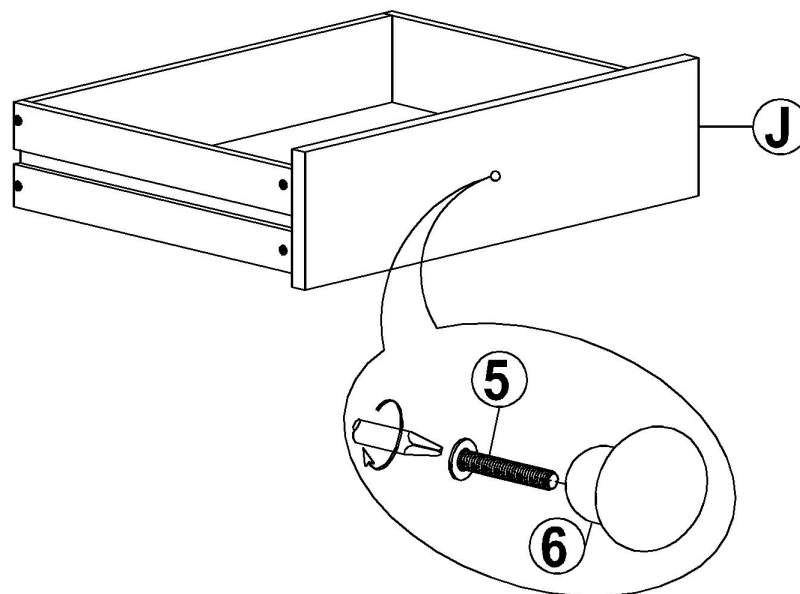

STEP 8

Put the drawer into the unit as shown below.

Insert brackets (7) into the unit. Place adjustable shelf (F) on the brackets and attach with screws (9) as shown below.

